

2900 SERIES REED RELAYS

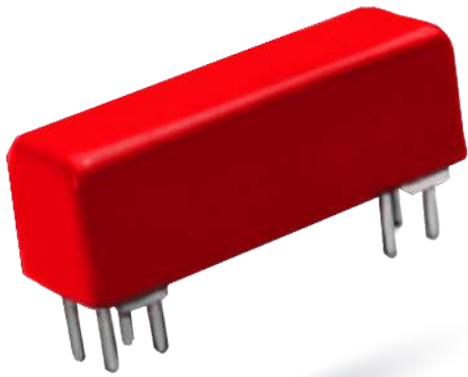

2900 Series Reed Relays

Ideally suited to the needs of Automated Test Equipment and RF requirements. The specification tables allow you to select the appropriate relay for your particular application. Slightly larger than the 2200 Series; these relays provide maximum versatility with options such as a Form C with electrostatic or co-axial shielding. If your requirements differ, please consult your local representative or Coto's Factory.

2900 Series Features

- ▶ Very small (0.20 in²), high reliability reed relays
- ▶ High Insulation Resistance - $10^{12}\Omega$ offered on 2904
- ▶ High speed switching compared to electromechanical relays
- ▶ Hermetically sealed contacts for long life
- ▶ Epoxy coated steel shell provides magnetic shielding
- ▶ Optional Electrostatic Shield for reducing capacitive coupling
- ▶ Optional Coaxial Shield for 50 Ω impedance and switching of fast rise time digital pulses
- ▶ RoHS compliant (except for 2920)

DIMENSIONS

in Inches (Millimeters)

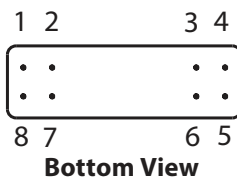
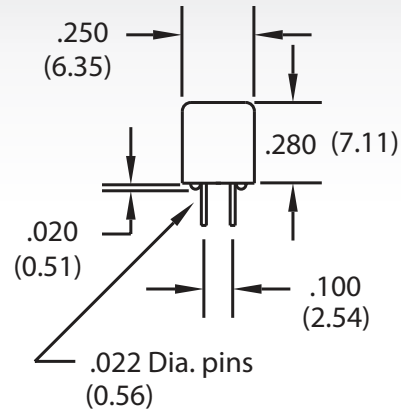
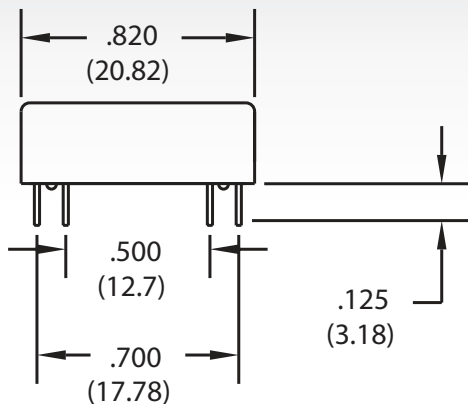

Ordering Information

Model Number	Part Number	Coil Voltage	Shielding Options ²
2904	29XX-XX-XX1	05=5 volts	0=No Shield
2911		12=12 volts	1=Electrostatic Shield
2920			2=Co-axial Shield

Coil Options

- 1=Use for Model #2920 (5 & 12 volt coil)
- 3=Use for Model #2904 (12 volt coil) and for Model #2911 (5 & 12 volt coil)
- 4=Use for Model #2904 (5 volt coil)

02272015

MODEL NUMBER			2904 ²	2911 ²	2920 ^{2,3}
Parameters	Test Conditions	Units	1 Form A	1 Form C	1Form A Hg Wetted
COIL SPECS.					
Nom. Coil Voltage		VDC	5 12	5 12	5 12
Coil Resistance	+/- 10%, 25° C	Ω	370 1500	230 1500	75 425
Operate Voltage	Must Operate by	VDC - Max.	3.8 9.0	3.8 9.0	3.8 9.0
Release Voltage	Must Release by	VDC - Min.	0.4 1.0	0.4 1.0	0.4 1.0
CONTACT RATINGS					
Switching Voltage	Max DC/Peak AC Resist.	Volts	200	150	500
Switching Current	Max DC/Peak AC Resist.	Amps	0.5	0.25	1.0
Carry Current	Max DC/Peak AC Resist.	Amps	1.5	1.0	2.0
Contact Rating	Max DC/Peak AC Resist.	Watts	10	3	50
Life Expectancy-Typical ¹	Signal Level 1.0V, 10mA	x 10 ⁶ Ops.	500	100	1000
Static Contact Resistance (max. init.)	50mV, 10mA	Ω	0.100	0.150	0.075
Dynamic Contact Resistance (max. init.)	0.5V, 50mA at 100 Hz, 1.5 msec	Ω	0.200	0.200	0.100
RELAY SPECIFICATIONS					
Insulation Resistance (minimum)	Between all Isolated Pins at 100V, 25°C, 40% RH	Ω	10 ¹²	10 ¹¹	10 ¹⁰
Capacitance - Typical Across Open Contacts	Shield Floating	pF	1.0	2.0	1.4
	Shield Guarding	pF	0.3	1.0	0.2
Dielectric Strength (minimum)	Between Contacts	VDC/peak AC	350	200	1000
	Contacts to Coil	VDC/peak AC	350	200	1000
	Contacts/Shield to Coil	VDC/peak AC	1500	1500	1500
Operate Time - including bounce - Typical	At Nominal Coil Voltage, 30 Hz Square Wave	msec.	0.5	1.0	1.5
Release Time - Typical		msec.	0.1	2.0	1.0

Top View:
Grid = .1"x.1" (2.54mm x 2.54mm)

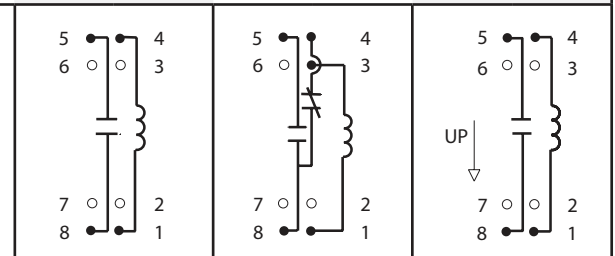

Notes:

- ¹ Consult factory for life expectancy at other switching loads.
- ² Model 2904, 2911 and 2920, pin #7 is tied to optional electrostatic shield, pins #6 & #7 are tied to optional coaxial shield.
- ³ Model 2920 has Hg wetted contacts - position sensitive, must be mounted within 30° of vertical plane. See schematic.
Hg Content per capsule: Form A, 0.04 grams.

Environmental Ratings:

Storage Temp: -35°C to +100°C; Operating Temp: -20°C to +85°C; Solder Temp: 270°C max; 10 sec. max
All electrical parameters measured at 25°C unless otherwise specified.
Vibration: 20 G's to 2000 Hz; Shock: 50 G's

02272015