

NCT275

Industry Standard Digital Temperature Sensor in CSP Package with 2-wire Interface

The NCT275 is a two-wire serially programmable temperature sensor with an over-temperature/interrupt output pin to signal out of limit conditions. This is an open-drain pin and can operate in either comparator or interrupt mode. Temperature measurements are converted into digital form using a high resolution (12 bit), sigma-delta, analog-to-digital converter (ADC). The device operates over the -55°C to $+125^{\circ}\text{C}$ temperature range.

Communication with the NCT275 is accomplished via the SMBus/I²C interface which is compatible with industry standard protocols. Through this interface the NCT275s internal registers may be accessed. These registers allow the user to read the current temperature, change the configuration settings and adjust the temperature limits.

The NCT275 has a wide supply voltage range of 3.0 V to 5.5 V. The average supply current is 575 μA at 3.3 V. It also offers a shutdown mode to conserve power. The typical shutdown current is 3 μA .

The NCT275 is available in a space saving 6 ball CSP package as NCT275A and NCT275B. NCT275B gives I²C address options of 0x48 and 0x4A while NCT275A gives address options of 0x49 and 0x4B. NCT275 is also fully register compatible with the NCT75, LM75 and TMP75.

Features

- 12-bit Temperature-to-Digital Converter
- Input Voltage Range from 3.0 V to 5.5 V
- Temperature Range from -55°C to $+125^{\circ}\text{C}$
- SMBus/I²C Interface
- Over Temperature Indicator
- Support for SMBus ALERT
- Shutdown Mode for Low Power Consumption
- One-Shot Mode
- Available in 6 Ball CSP Package with Multiple Address Options
- These are Pb-Free Devices

Typical Applications

- Computer Thermal Monitoring
- Thermal Protection
- Isolated Sensors
- Battery Management
- Office Electronics
- Electronic Test Equipment
- Thermostat Controls
- System Thermal Management



ON Semiconductor®

<http://onsemi.com>



WLCSP6
CASE 567JR

MARKING DIAGRAM

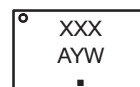

XXX = 75A (NCT275A)
= 75B (NCT275B)
A = Assembly Location
Y = Year
W = Work Week
■ = Pb-Free Package

PIN CONNECTIONS

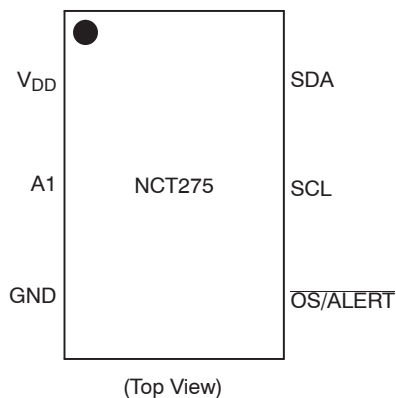
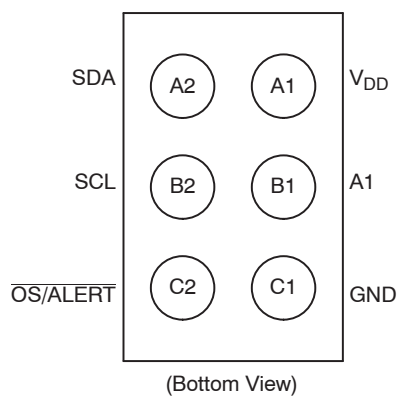

ORDERING INFORMATION

See detailed ordering and shipping information on page 12 of this data sheet.

NCT275

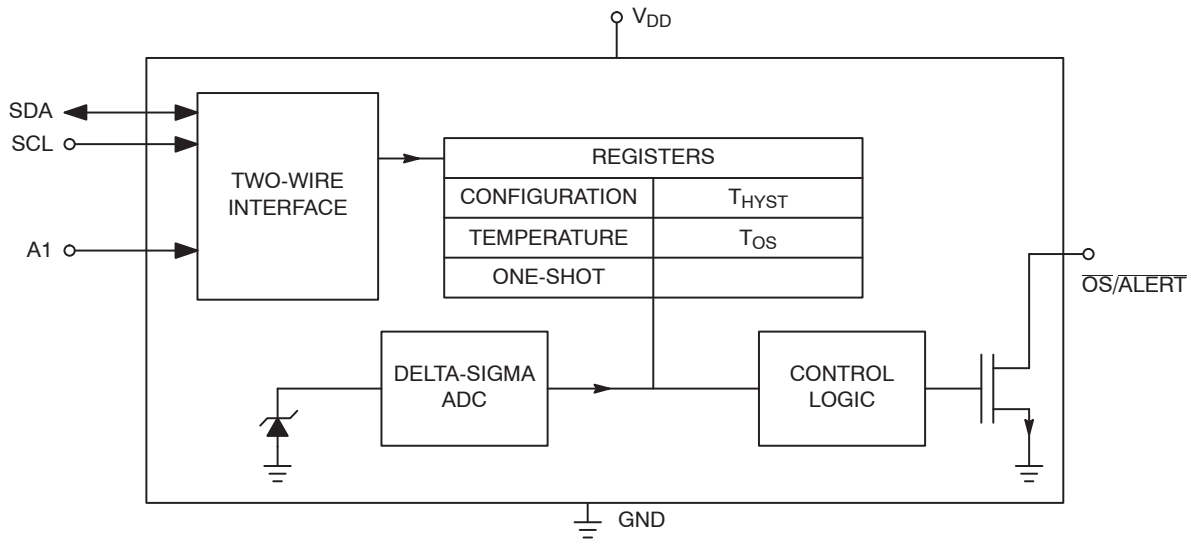

Figure 1. Simplified Block Diagram

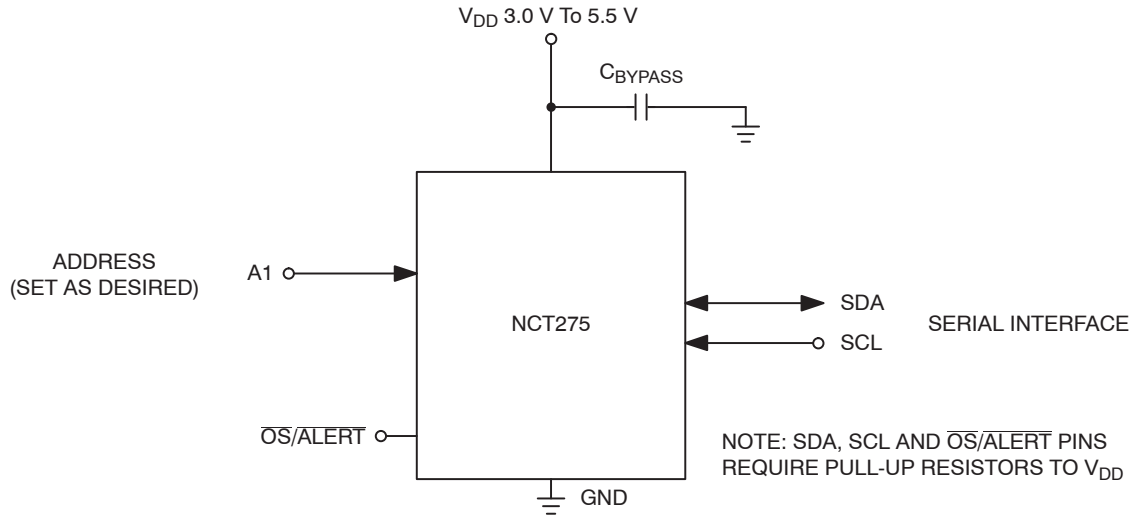

Figure 2. Typical Application Circuit

BALL FUNCTION DESCRIPTION

Ball Name	Ball Function	Description
A2	SDA	SMBus/I ² C Serial Bi-directional Data Input/Output. Open-drain pin; needs a pull-up resistor.
A1	V _{DD}	Positive Supply Voltage, 3.0 V to 5.5 V. Bypass to ground with a 0.1μF bypass capacitor.
B2	SCL	Serial Clock Input. Open-drain pin; needs a pull-up resistor.
B1	A1	SMBus/I ² C Serial Bus Address Selection Pin. Connect to GND or V _{DD} to set the desired I ² C address.
C2	OS/ALERT	Over-temperature Indicator. Open-drain output; needs a pullup resistor.
C1	GND	Power Supply Ground.

NCT275

ABSOLUTE MAXIMUM RATINGS

Rating	Symbol	Value	Unit
Supply Voltage	V_{DD}	-0.3 to +7	V
Input voltage on SCL, SDA, and A1.		-0.3 V to $V_{DD} + 0.3$ V	V
Input current on SDA and A1.	I_{IN}	-1 to +50	mA
Maximum Junction Temperature	$T_{J(max)}$	150.7	°C
Operating Temperature Range	T_{OP}	-55 to 125	°C
Storage Temperature Range	T_{STG}	-65 to 160	°C
ESD Capability, Human Body Model (Note 2)	ESD_{HBM}	2000	V
ESD Capability, Machine Model (Note 2)	ESD_{MM}	200	V

Stresses exceeding those listed in the Maximum Ratings table may damage the device. If any of these limits are exceeded, device functionality should not be assumed, damage may occur and reliability may be affected.

1. Refer to ELECTRICAL CHARACTERISTICS and APPLICATION INFORMATION for Safe Operating Area.
2. This device series incorporates ESD protection and is tested by the following methods:
 ESD Human Body Model tested per AEC-Q100-002 (EIA/JESD22-A114)
 ESD Machine Model tested per AEC-Q100-003 (EIA/JESD22-A115)

OPERATING RANGES (Note 3)

Rating	Symbol	Min	Max	Unit
Operating Input Voltage	V_{in}	3.0	5.5	V
Operating Ambient Temperature Range	T_A	-55	125	°C

Functional operation above the stresses listed in the Recommended Operating Ranges is not implied. Extended exposure to stresses beyond the Recommended Operating Ranges limits may affect device reliability.

3. Refer to ELECTRICAL CHARACTERISTICS and APPLICATION INFORMATION for Safe Operating Area.

SMBUS TIMING SPECIFICATIONS

Parameter	Symbol	Test Conditions	Min	Typ	Max	Unit
Serial Clock Frequency	f_{SCL}		DC	-	400	kHz
Start Condition Hold Time	$t_{HD:STA}$		0.6	-	-	μ s
Stop Condition Setup Time	$t_{SU:STO}$	90% of SCL to 10% of SDA	100	-	-	ns
Clock Low Period	t_{LOW}		1.3	-	-	μ s
Clock High Period	t_{HIGH}		0.6	-	-	μ s
Start Condition Setup Time	$t_{SU:STA}$	90% of SCL to 90% of SDA	100	-	-	ns
Data Setup Time	$t_{SU:DAT}$	10% of SDA to 10% of SCL	100	-	-	ns
Data Hold Time (Note 4)	$t_{HD:DAT}$	10% of SCL to 10% of SDA	0	-	76	ns
SDA/SCL Rise Time	t_R		-	300	-	ns
SDA/SCL Fall Time	t_F		-	300	-	ns
Minimum RESET Pulse Width	t_{RESET}		1.3	-	-	μ s
Bus Free Time Between STOP and START Conditions	t_{BUF}		1.3	-	-	μ s

4. This refers to the hold time when NCT275 is writing data to the bus

NCT275

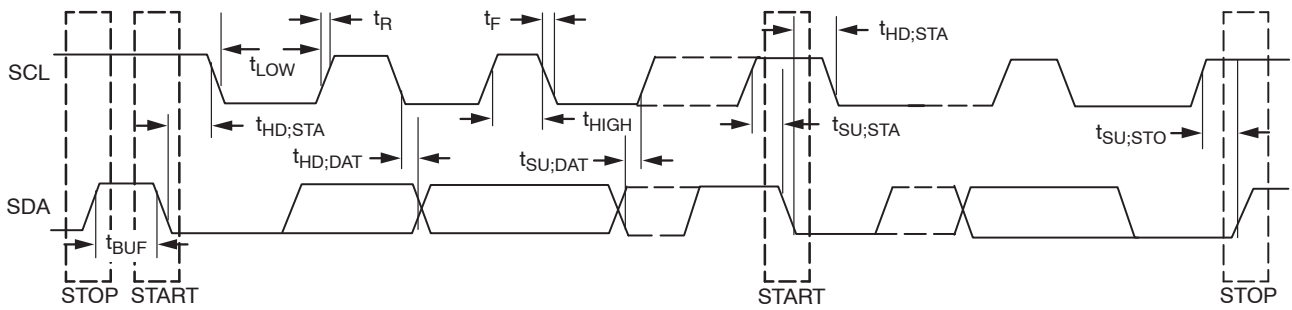

Figure 3. Serial Interface Timing

ELECTRICAL CHARACTERISTICS ($T_A = T_{MIN}$ to T_{MAX} , $V_{DD} = 3.0$ V to 5.5 V. All specifications for -55°C to $+125^{\circ}\text{C}$, unless otherwise noted)

Parameter	Test Conditions	Min	Typ	Max	Unit
TEMPERATURE SENSOR AND ADC					
Accuracy at $V_{DD} = 3.0$ V to 5.5 V	$T_A = 0^{\circ}\text{C}$ to $+70^{\circ}\text{C}$ $T_A = -25^{\circ}\text{C}$ to $+100^{\circ}\text{C}$ $T_A = -55^{\circ}\text{C}$ to $+125^{\circ}\text{C}$	-	-	± 1 ± 2 ± 3	$^{\circ}\text{C}$
ADC Resolution		-	12	-	Bits
Temperature Resolution		-	0.0625	-	$^{\circ}\text{C}$
Temperature Conversion Time	One Shot Mode	-	48.5	-	ms
Update Rate		-	80	-	ms
POWER REQUIREMENTS					
Supply Voltage		3.0	-	5.5	V
POR Threshold		2.75	-	-	V
Supply Current	Peak current while converting and I ² C interface inactive	-	-	0.8	mA
Average Current	Average current over 1 conversion cycle	-	0.44	0.575	mA
Shutdown Mode at 3.3 V	Supply current in shutdown mode	-	3	12	μA
OS/ALERT OUTPUT (OPEN DRAIN)					
Output Low Voltage, V_{OL}	$I_{OL} = 4$ mA	-	0.15	0.4	V
Pin Capacitance		-	10	-	pF
High Output Leakage Current, I_{OH}	OS/ALERT pin pulled up to 5.5 V	-	0.1	5	μA
DIGITAL INPUTS					
Input Current	$V_{IN} = 0$ V to V_{DD}	-	-	1	μA
Input Low Voltage, V_{IL}		-	-	$0.3 \times V_{DD}$	V
Input High Voltage, V_{IH}		$0.7 \times V_{DD}$	-	-	V
SCL, SDA Glitch Rejection	Input filtering suppresses noise spikes of less than 50 ns	-	-	50	ns
Pin Capacitance		-	3	-	pF
DIGITAL OUTPUT (OPEN DRAIN)					
Output High Current, I_{OH}	$V_{OH} = 5$ V	-	-	1	μA
Output Low Voltage, V_{OL}	$I_{OL} = 3$ mA	-	-	0.4	V
Output Capacitance, C_{OUT}		-	3	-	pF

Product parametric performance is indicated in the Electrical Characteristics for the listed test conditions, unless otherwise noted. Product performance may not be indicated by the Electrical Characteristics if operated under different conditions.

FUNCTIONAL DESCRIPTION

The NCT275 temperature sensor converts an analog temperature measurement to a digital representation by using an on-chip measurement transistor and a 12 bit Delta-Sigma ADC.

The device includes an open drain ALERT output which can be used to signal that the programmed temperature limit has been exceeded.

The two main modes of operation are normal and shutdown mode. In normal mode the NCT275 performs a new temperature conversion every 80 ms. This new value is then updated to the temperature value register (address 0x00) and also compared to the TOS register limit (default = 80°C). If the temperature value register is read during the conversion sequence the value returned is the previously stored value. A bus read does not affect the conversion that is in progress.

In shutdown mode temperature conversion is disabled and the temperature value register holds the last valid temperature reading. The NCT275 can still be communicated with in this mode as the interface is still active. The device mode is controlled via bit 0 of the configuration register. While in shutdown mode a conversion can be initiated by writing an arbitrary value to the one-shot register (0x04).

This has the effect of powering up the NCT275, performing a conversion, comparing the new temperature with the programmed limit and then going back into shutdown mode.

The OS/ALERT pin can be configured in many ways to allow it to be used in many different system configurations.

The over temperature output can be configured to operate as a comparator type output (which is self clearing once the temperature has returned below the hysteresis value) or an interrupt type output (which requires the master to read an internal register AND the temperature to return below the hysteresis value before going into an inactive state). The ALERT pin can also be configured as an active high or active low output.

While the ADC of the NCT275 can theoretically measure temperatures in the range of -128°C to 127°C, the NCT275 is guaranteed to measure from -55°C to +125°C. Table 1 shows the relevant temperature bits for a 12 bit temperature reading. A 2-byte read is required to obtain the full 12 bit temperature reading. If an 8 bit (1°C resolution) reading is required then a single byte read is sufficient.

Temperature Measurement Results

The results of the on chip temperature measurements are stored in the temperature value register and compared with the T_{OS} and T_{HYST} limit register.

The temperature value, T_{OS} and T_{HYST} registers are 16 bits wide and have a resolution of 0.0625°C. The data is stored as a 12 bit 2s complement word. The data is left justified; D15 is the MSB and is the sign bit. The four LSBs (D3 to D0) are always 0 as they are not part of the result.

Table 1. 12-Bit TEMPERATURE DATA FORMAT

Temperature	Binary Value D15 to D4	Hex Value
-55	1100 1001 0000	0xC90
-25	1110 0111 0000	0xE70
-0.0625	1111 1111 1111	0xFFF
0	0000 0000 0000	0x000
+0.0625	0000 0000 0001	0x001
+25	0001 1001 0000	0x190
+75.25	0100 1011 0100	0x4B4
+100	0110 0100 0000	0x640
+125	0111 1101 0000	0x7D0

12-Bit Temperature Data Format

Positive Temperature = ADC Code (decimal)/16
Example 190h = 400d/16 = +25 °C

Negative Temperature = (ADC Code(decimal) - 4096)/16
Example E70h = (3696d - 4096)/16 = -25 °C

ONE-SHOT MODE

One of the features of the NCT275 is a One-Shot Temperature Measurement Mode. This mode is useful if reduced power consumption is a design requirement.

To enable one-shot mode bit 5 of the configuration register need to be set. Once, enabled, the NCT275 goes immediately into shutdown mode. Here, the current consumption is reduced to a typical value of 3 µA. Writing address 0x04 to the address pointer register initiates a one-shot temperature measurement. This powers up the NCT275, carries out a temperature measurement, and then powers down again. The data written to this register is irrelevant and is not stored. It is the write operation that causes the one-shot conversion.

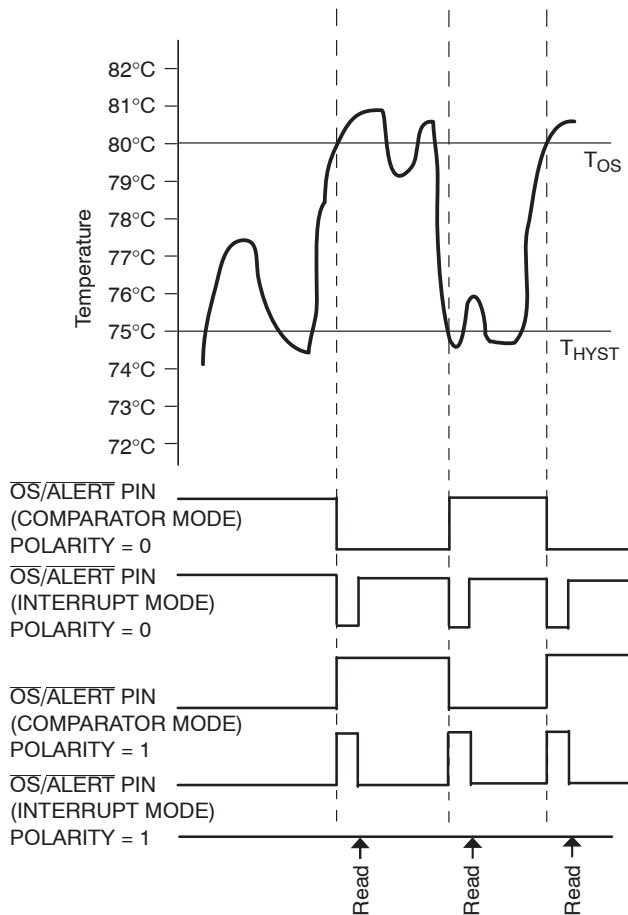

Figure 4. One-shot $\overline{\text{OS/ALERT}}$ Pin Operation

FAULT QUEUE

A fault is defined as when the temperature exceeds a pre-defined temperature limit. This limit can be programmed in the T_{HYST} and the T_{OS} setpoint registers. Bits 3 and 4 of the configuration register determine the number of faults necessary to trigger the OS/ALERT pin. Up to six faults can be programmed to prevent false tripping when the NCT275 is used in a noisy temperature environment. In order for the OS/ALERT output to be set these faults must occur consecutively.

REGISTERS

The NCT275 contains six registers for configuring and reading the temperature: the address pointer register, 4 data registers and a one-shot register. The configuration register, the address pointer register and the one-shot register are all 8 bits wide while the temperature register, T_{HYST} and T_{OS} registers are all 16 bits wide. All registers, except for the

temperature register, can be read from and written to (the temperature register is read only). The power on state and address of each register are listed in Table 4.

Address Pointer Register

The address pointer register is used to select which register is to respond to a read or write operation. The three LSBs (P2, P1 & P0) of this write only register are used to select the appropriate register. On power up this register is loaded with a value of 0x00 and so points to the temperature register. Table 2 shows the bits of the address pointer register and Table 3 shows the pointer address selecting each of the registers available.

Table 2. ADDRESS POINTER REGISTER

		P6	P5	P4	P3	P2	P1	P0
Default	0	0	0	0	0	0	0	0

Table 3. REGISTER ADDRESSES SELECTION

P2	P1	P0	Register Selected
0	0	0	Stored Temperature
0	0	1	Configuration
0	1	0	T_{HYST} set point
0	1	1	T_{OS} set point
1	0	0	One-shot

Table 4. NCT275 REGISTER SET

Register Address	Register Name	Power-On Default Value	
		Hex	°C
0x00 (R)	Stored Temperature Value	0x0000	0
0x01 (R/W)	Configuration	0x00	-
0x02 (R/W)	T_{HYST}	0x4B00	75
0x03 (R/W)	T_{OS}	0x5000	80
0x04 (R/W)	One-Shot	0xXX	-

Temperature Register

The temperature measured by the parts internal sensor is stored in this 16-bit read only register. The data is stored in twos complement format with the MSB as the sign bit. The 8 MSBs must be read first followed by the 8 LSBs.

Table 5. TEMPERATURE VALUE REGISTER

MSB															LSB
D15	D14	D13	D12	D11	D10	D9	D8	D7	D6	D5	D4	D3	D2	D1	D0
0	0	0	0	0	0	0	0	0	0	0	0	X	X	X	X

Configuration Register

This 8-bit read/write register is used to configure the NCT275 into its various modes of operation. The different modes are listed in Table 6 and explained in more detail below.

Table 6. CONFIGURATION REGISTER

	Configuration	Default Value
D7	OS/SMBus Alert	0
D6	Reserved	0
D5	One-shot Mode	0
D4	Fault-queue	0
D3	Fault-queue	0
D2	OS/Alert pin polarity	0
D1	Cmp/Int Mode	0
D0	Shutdown Mode	0

D7: OS/SMBus Alert Mode.

D7 = 0 SMBus alert disabled, pin operates as an over temperature shutdown pin. (Default)

D7 = 1 Enable SMBus alert functionality for the NCT275.

D6: Reserved

Write 0 to this bit.

D5: One-Shot Mode

D5 = 0 Part is in normal mode and converting every 60 ms. (Default)

D5 = 1 Setting this bit puts the part into one-shot mode. The part is normally powered down in this mode until the one shot register is written to. Once

this register is written to one conversion is performed and the part returns to its shutdown state.

D[4:3]: Fault Queue

D4 D3 These two bits determine how many over temperature conditions occur before the OS/Alert pin is triggered. This helps to prevent false triggering of the output.

0 0 = 1 Fault (Default)

0 1 = 2 Faults

1 0 = 4 Faults

2 1 = 6 Faults

D2: OS/Alert pin polarity

This selects the polarity of the OS/Alert output pin.

D2 = 0 Output is active low. (Default)

D2 = 1 Output is active high.

D1: Cmp/Int

D1 = 0 Comparator mode. (Default)

D1 = 1 Interrupt mode.

D0: Shutdown

D0 = 0 Normal mode – part is fully powered. (Default)

D0 = 1 Shutdown mode – all circuitry except for the SMBus interface is powered down. Write a 0 to this bit to power up again.

T_{HYST} Register

The T_{HYST} register stores the temperature hysteresis value for the overtemperature output. This value is picked to stop the OS/Alert pin from being asserted and de-asserted in noisy temperature environments. This limit is stored in the 16 bit register in twos complement format. The MSB is the temperature sign bit. The 8 MSBs must be read first followed by the 8 LSBs. The default value is +75°C.

Table 7. T_{HYST} REGISTER

MSB															LSB
D15	D14	D13	D12	D11	D10	D9	D8	D7	D6	D5	D4	D3	D2	D1	D0
0	1	0	0	1	0	1	1	0	0	0	0	X	X	X	X

T_{OS} Register

This register stores the temperature limit at which the part asserts an OS/Alert. Once the measured temperature reaches this value an alert or overtemperature output is generated.

The data is stored in twos complement format with the MSB as the sign bit. The 8 MSBs must be read frist followed by the 8 LSBs. The default limit +80°C.

Table 8. T_{OS} REGISTER

MSB															LSB
D15	D14	D13	D12	D11	D10	D9	D8	D7	D6	D5	D4	D3	D2	D1	D0
0	1	0	1	0	0	0	0	0	0	0	0	X	X	X	X

SERIAL INTERFACE

Control of the NCT275 is carried out via the SMBus/I²C compatible serial interface. The NCT275 is connected to this bus as a slave device, under the control of a master device.

Serial Bus Address

Control of the NCT275 is carried out via the serial bus. The NCT275 is connected to this bus as a slave device under the control of a master device.

There are two NCT275 device options called NCT275A and NCT275B. Each device supports two possible addresses depending on Ball A2 (named A1) is connected high or low. The NCT275 has a 7-bit serial address. The four MSBs are fixed and set to 1001 while the 3 LSBs can be configured by the user using Ball A2 (named A1). The ball A2 can be connected to VDD or ground.

Table 9. NCT275A SERIAL BUS ADDRESS OPTIONS

Ball A2	I ² C Address
0	0x49
1	0x4B

Table 10. NCT275B SERIAL BUS ADDRESS OPTIONS

Ball A2	I ² C Address
0	0x48
1	0x4A

The NCT275 also features a SMBus/I²C timeout function whereby the SMBus/I²C interface times out after 25 ms of no activity on the SDA line. After this time, the NCT275 resets the SDA line back to its idle state (high impedance) and waits for the next start condition.

The serial bus protocol operates as follows:

1. The master initiates data transfer by establishing a start condition, defined as a high to low transition on the serial data line SDA, while the serial clock line SCL remains high. This indicates that an address/data stream is going to follow. All slave peripherals connected to the serial bus respond to the start condition and shift in the next eight bits, consisting of a 7-bit address (MSB first) plus a read/write (R/W) bit, which determines the direction of the data transfer i.e. whether data is written to, or read from, the slave device. The peripheral with the address corresponding to the transmitted address responds by pulling the data line low during the low period before the ninth clock pulse, known as the acknowledge bit. All other devices on the bus now remain idle while the

selected device waits for data to be read from or written to it. If the R/W bit is a zero then the master writes to the slave device. If the R/W bit is a one then the master reads from the slave device.

2. Data is sent over the serial bus in sequences of nine clock pulses, eight bits of data followed by an acknowledge bit from the receiver of data. Transitions on the data line must occur during the low period of the clock signal and remain stable during the high period, since a low-to-high transition when the clock is high can be interpreted as a stop signal.
3. When all data bytes have been read or written, stop conditions are established. In write mode, the master pulls the data line high during the tenth clock pulse to assert a stop condition. In read mode, the master overrides the acknowledge bit by pulling the data line high during the low period before the ninth clock pulse. This is known as no acknowledge. The master takes the data line low during the low period before the tenth clock pulse, then high during the tenth clock pulse to assert a stop condition.

Any number of bytes of data can be transferred over the serial bus in one operation. However, it is not possible to mix read and write in one operation because the type of operation is determined at the beginning and cannot subsequently be changed without starting a new operation.

WRITING DATA

There are two types of writes used in the NCT275:

Setting up the Address Pointer Register for a Register Read

To read data from a particular register, the address pointer register must hold the address of the register being read. To configure the address pointer register a single write operation (shown in Figure 5). It consists of the device address followed by the address being written to the address pointer register. This will then be followed by a read operation.

Writing Data to a Register

Due to the different size registers used by the NCT275, there are two types of write operations. One is for the 8 bit wide configuration register and the other for the 16 bit wide limit registers.

Figure 6 shows the sequence required to write to the configuration register. It consists of the device address, the data register being written to and the data being written the selected register.

The two temperature limit registers (T_{HYST} and T_{OS}) are 16 bits wide and require two data bytes to be written to these registers. This sequence is shown in Figure 7. It consists of the device address, the data register being written to and the two data bytes being written to the selected register.

NCT275

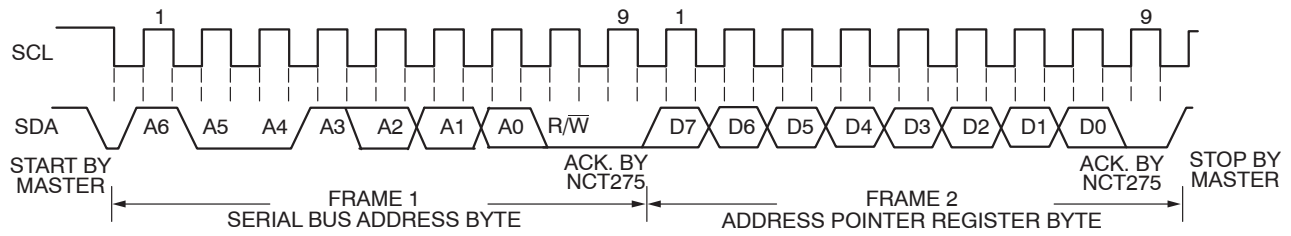

Figure 5. Writing to the Address Pointer Register

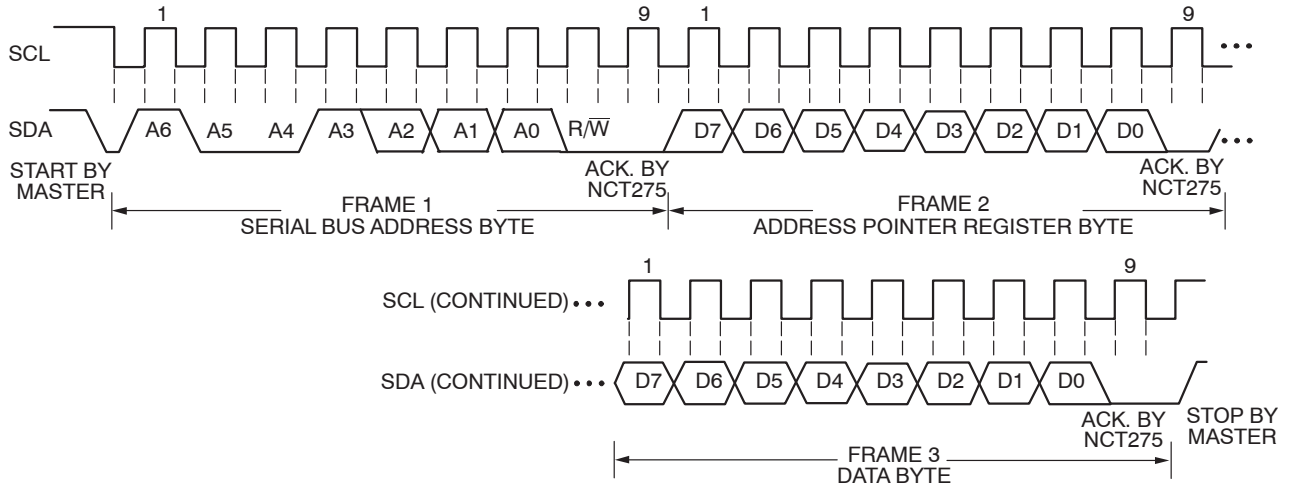

Figure 6. Writing a Register Address to the Address Pointer Register, then Writing a Single Byte of Data to the Configuration Register

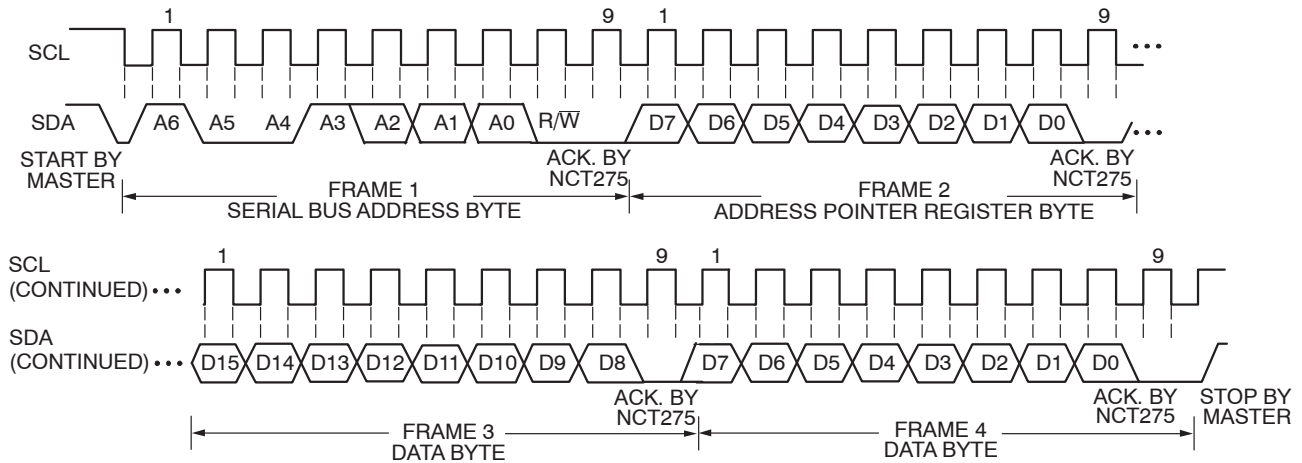

Figure 7. Writing to the Address Pointer Register Followed by Two Bytes of Data to a 16 Bit Limit Register

NCT275

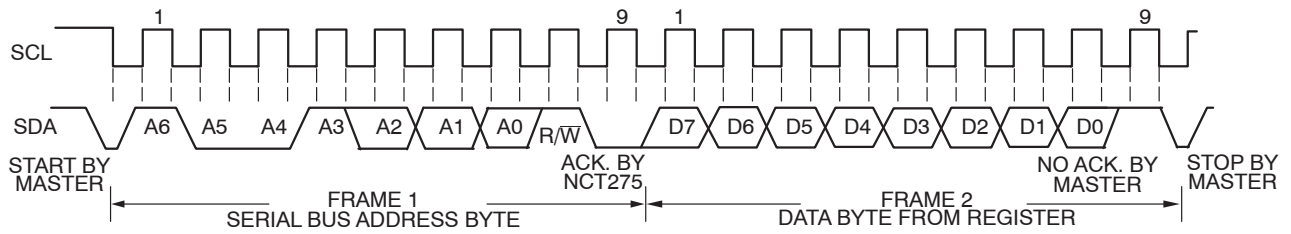

Figure 8. Reading Data from the Configuration Register

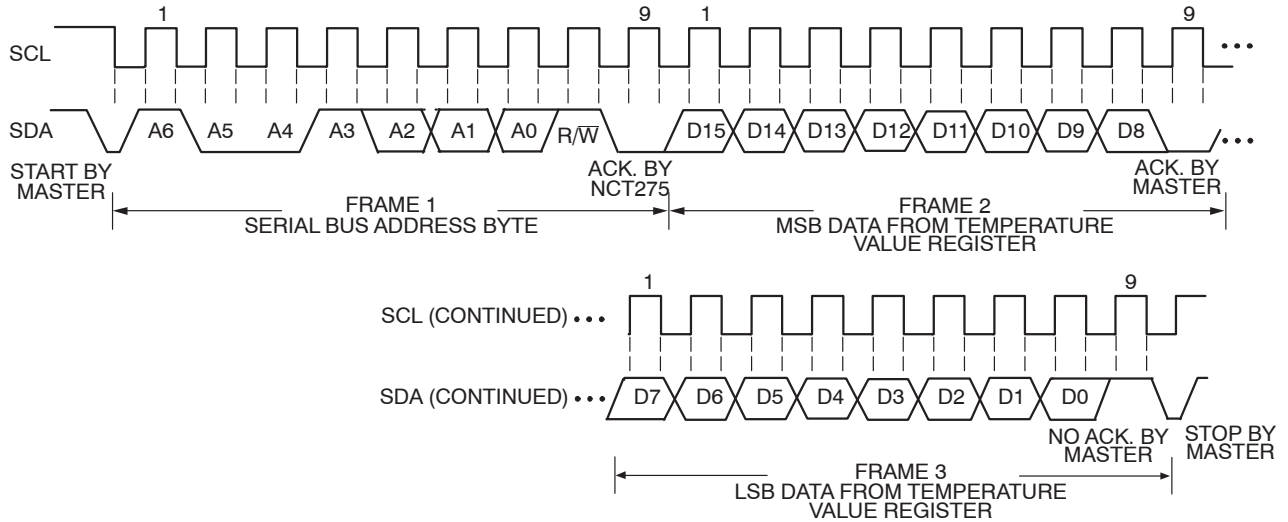

Figure 9. Reading Data from the Temperature Value Register with Preset Pointer

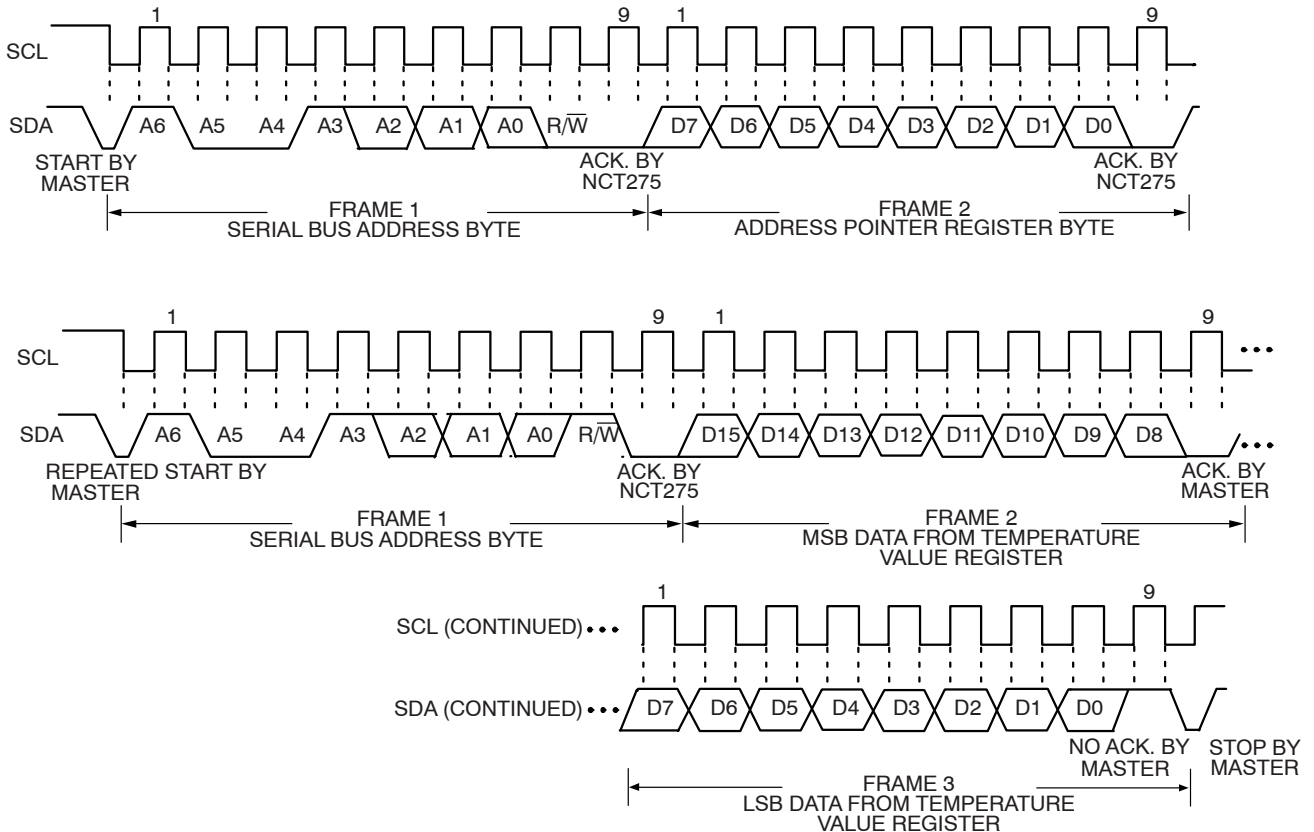

Figure 10. Typical Pointer Set Followed by Two Bytes Read

READING DATA

Reading data from the NCT275 is done in two different ways depending on the register being read. The configuration register is only 8 bits wide so a single byte read is used for this (shown in Figure 8). This consists of the device address followed by the data from the register.

Reading the data in the temperature value register requires a two byte read (shown in Figure 9). This consists of the device address, followed by two bytes of data from the temperature register (the first byte is the MSB). In both cases the address pointer register of the register being read must be written to prior to performing a read operation.

OS/ALERT OUTPUT OVERTEMPERATURE MODES

The OS/ALERT output pin can operate in two different modes – overtemperature mode and SMBus

alert mode. The pin defaults to overtemperature mode on power up. This means that it becomes active when the measured temperature meets or exceeds the limit stored in the T_{OS} setpoint register. At this point it can deal with the event in one of two ways which depends on the mode it is in. The two overtemperature modes are comparatormode and interrupt mode. Comparator is the default mode on power

up. More information on comparator and interrupt modes along with the SMBus alert mode are explained below.

Comparator Mode

In Comparator Mode, the OS/ALERT pin becomes active when the measured temperature equals or exceeds the limit stored in the T_{OS} setpoint register. The pin returns to its inactive status when the temperature drops below the T_{HYST} setpoint register value.

NOTE: Shutdown mode does not reset the output state for comparator mode.

Interrupt Mode

In the interrupt mode, the OS/ALERT pin becomes active when the temperature equals or exceeds the T_{OS} limit for a consecutive number of faults. It can be reset by performing a read operation on any register in the NCT275. The output can only become active again when the T_{OS} limit has been equalled or exceeded. Figure 11 shows how both the interrupt and comparator modes operate in relation to the output pin (OS/ALERT). It also shows the operation of the polarity in the configuration register.

NCT275

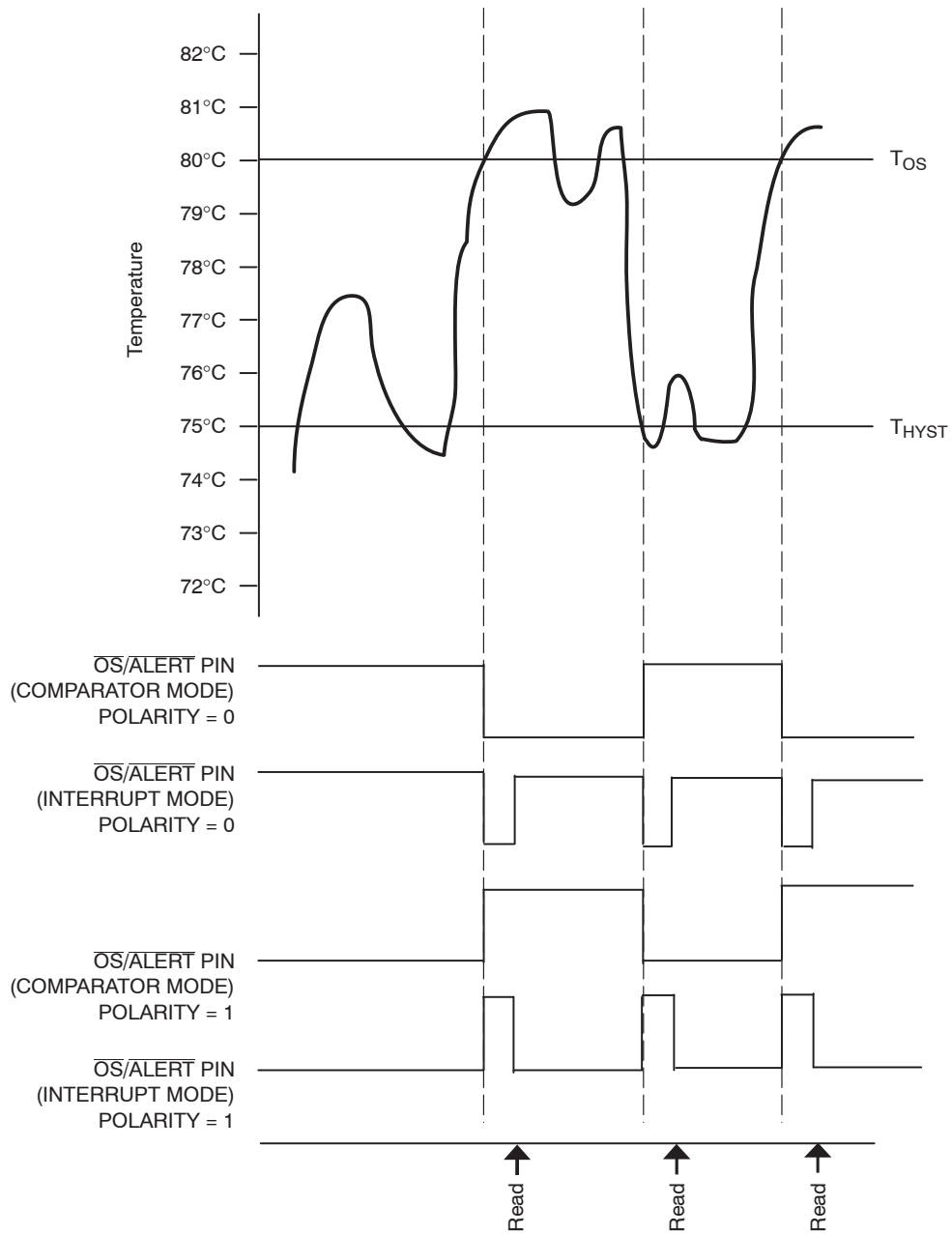

Figure 11. $\overline{\text{OS}}/\overline{\text{ALERT}}$ Output Temperature Response Diagram

Table 11. ORDERING INFORMATION

Part Number	I ² C Address	Package	Shipping [†]
NCT275AFCT2G	0x49 & 0x4B	WLCSP6 (Pb-Free)	3000 / Tape & Reel
NCT275BFCT2G	0x48 & 0x4A	WLCSP6 (Pb-Free)	3000 / Tape & Reel

[†]For information on tape and reel specifications, including part orientation and tape sizes, please refer to our Tape and Reel Packaging Specifications Brochure, BRD8011/D.

NCT275

PACKAGE DIMENSIONS

WLCSP6, 1.355x0.845
CASE 567JR
ISSUE A

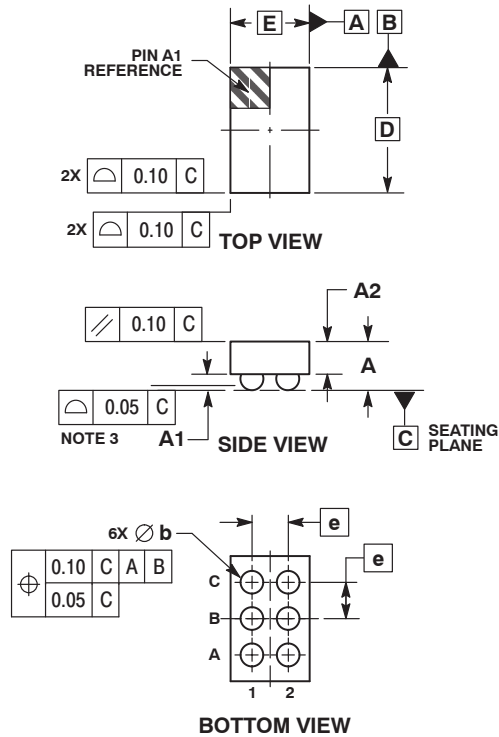

NOTES:

1. DIMENSIONING AND TOLERANCING PER ASME Y14.5M, 1994.
2. CONTROLLING DIMENSION: MILLIMETERS.
3. COPLANARITY APPLIES TO SPHERICAL CROWNS OF SOLDER BALLS.
4. DIMENSION b IS MEASURED AT THE MAXIMUM BALL DIAMETER PARALLEL TO DATUM C.

DIM	MILLIMETERS	
	MIN	MAX
A	---	0.60
A1	0.18	0.22
A2	0.36 REF	
b	0.24	0.30
D	1.355 BSC	
E	0.845 BSC	
e	0.40 BSC	

RECOMMENDED SOLDERING FOOTPRINT*

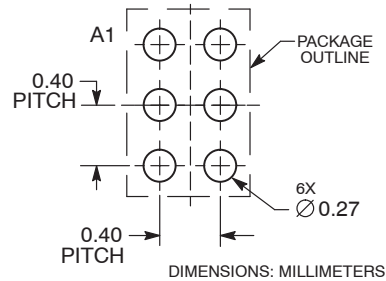

*For additional information on our Pb-Free strategy and soldering details, please download the ON Semiconductor Soldering and Mounting Techniques Reference Manual, SOLDERRM/D.

ON Semiconductor and the are registered trademarks of Semiconductor Components Industries, LLC (SCILLC) or its subsidiaries in the United States and/or other countries. SCILLC owns the rights to a number of patents, trademarks, copyrights, trade secrets, and other intellectual property. A listing of SCILLC's product/patent coverage may be accessed at www.onsemi.com/site/pdf/Patent-Marking.pdf. SCILLC reserves the right to make changes without further notice to any products herein. SCILLC makes no warranty, representation or guarantee regarding the suitability of its products for any particular purpose, nor does SCILLC assume any liability arising out of the application or use of any product or circuit, and specifically disclaims any and all liability, including without limitation special, consequential or incidental damages. "Typical" parameters which may be provided in SCILLC data sheets and/or specifications can and do vary in different applications and actual performance may vary over time. All operating parameters, including "Typicals" must be validated for each customer application by customer's technical experts. SCILLC does not convey any license under its patent rights nor the rights of others. SCILLC products are not designed, intended, or authorized for use as components in systems intended for surgical implant into the body, or other applications intended to support or sustain life, or for any other application in which the failure of the SCILLC product could create a situation where personal injury or death may occur. Should Buyer purchase or use SCILLC products for any such unintended or unauthorized application, Buyer shall indemnify and hold SCILLC and its officers, employees, subsidiaries, affiliates, and distributors harmless against all claims, costs, damages, and expenses, and reasonable attorney fees arising out of, directly or indirectly, any claim of personal injury or death associated with such unintended or unauthorized use, even if such claim alleges that SCILLC was negligent regarding the design or manufacture of the part. SCILLC is an Equal Opportunity/Affirmative Action Employer. This literature is subject to all applicable copyright laws and is not for resale in any manner.

PUBLICATION ORDERING INFORMATION

LITERATURE FULFILLMENT:
Literature Distribution Center for ON Semiconductor
P.O. Box 5163, Denver, Colorado 80217 USA
Phone: 303-675-2175 or 800-344-3860 Toll Free USA/Canada
Fax: 303-675-2176 or 800-344-3867 Toll Free USA/Canada
Email: orderlit@onsemi.com

N. American Technical Support: 800-282-9855 Toll Free
USA/Canada
Europe, Middle East and Africa Technical Support:
Phone: 421 33 790 2910
Japan Customer Focus Center
Phone: 81-3-5817-1050

ON Semiconductor Website: www.onsemi.com
Order Literature: <http://www.onsemi.com/orderlit>

For additional information, please contact your local Sales Representative