

DC Brushless Fan Motor Driver

# Standard Single-phase Full wave Fan motor driver

**BD6964F**

**Description**

This is the summary of application for BD6964F. BD6964F can drive FAN motor silently by BTL soft switching, and it can control rotational speed by PWM signal.

**Features**

- BTL soft switching drive
- PWM speed control
- Quick start function
- Lock protection and auto restart (without external capacitor)
- Lock alarm signal (AL) output

**Package**

SOP8

W(Typ) x D(Typ) x H(Max)

5.00mm x 6.20mm x 1.71mm

**Application**

- PC, PC peripheral component (Power supply, VGA card, case FAN etc.)
- BD player, Projector etc.



**Absolute Maximum Ratings**

Parameter	Symbol	Limit	Unit
Supply Voltage	V <sub>CC</sub>	15	V
Power Dissipation	P <sub>d</sub>	0.78 <sup>(Note 1)</sup>	W
Operating Temperature	T <sub>opr</sub>	-40 to +105	°C
Storage Temperature	T <sub>stg</sub>	-55 to +150	°C
Output Voltage	V <sub>OMAX</sub>	15	V
Output Current	I <sub>OMAX</sub>	1000 <sup>(Note 2)</sup>	mA
AL Signal Output Voltage	V <sub>AL</sub>	15	V
AL Signal Output Current	I <sub>AL</sub>	10	mA
Junction Temperature	T <sub>jmax</sub>	150	°C

(Note 1) Reduce by 6.24mW/°C over 25°C. (On 70.0mm×70.0mm×1.6mm glass epoxy board)

(Note 2) This value is not to exceed P<sub>d</sub>.

**Caution:** Operating the IC over the absolute maximum ratings may damage the IC. The damage can either be a short circuit between pins or an open circuit between pins and the internal circuitry. Therefore, it is important to consider circuit protection measures, such as adding a fuse, in case the IC is operated over the absolute maximum ratings.

## Recommended Operating Conditions

Parameter	Symbol	Limit	Unit
Operating supply voltage range	V <sub>CC</sub>	3.3 to 14	V
Hall input voltage range	V <sub>H</sub>	0 to V <sub>CC</sub> /3	V

Electrical Characteristics (Unless otherwise specified Ta=25°C, V<sub>CC</sub>=12V)

Parameter	Symbol	Limits			Unit	Conditions	Characteristics
		Min	Typ	Max			
Circuit Current 1	I <sub>CC1</sub>	1	3	5	mA	PWM=GND	Figure 1
Circuit Current 2	I <sub>CC2</sub>	2	5	8	mA	PWM=OPEN	Figure 2
Input Offset Voltage	V <sub>HOFs</sub>	-	-	±6	mV		-
PWM Input H Level	V <sub>PWMH</sub>	2.0	-	V <sub>CC</sub> +0.3	V		-
PWM Input L Level	V <sub>PWML</sub>	-0.3	-	0.8	V		-
PWM Input Current	I <sub>PWMH</sub>	11	22	33	μA	PWM=5V	Figure 3
	I <sub>PWML</sub>	-42	-28	-14	μA	PWM=GND	Figure 3
Input Frequency	F <sub>PWM</sub>	0.02	-	50	kHz		-
Output Voltage	V <sub>O</sub>	-	0.4	0.6	V	I <sub>O</sub> =300mA Upper and Lower total	Figure 4 to 7
Input-output Gain	G <sub>IO</sub>	45	48	51	dB		-
AL Low Voltage	V <sub>ALL</sub>	-	-	0.4	V	I <sub>AL</sub> =5mA	Figure 8,9
AL Leak Current	I <sub>ALL</sub>	-	-	20	μA	V <sub>AL</sub> =15V	Figure 10
Lock Detection ON time	t <sub>ON</sub>	0.35	0.50	0.65	s		Figure 11
Lock Detection OFF time	t <sub>OFF</sub>	3.5	5.0	6.5	s		Figure 12

## Truth Table

H+	H-	PWM	OUT1	OUT2
H	L	H(OPEN)	H	L
L	H	H(OPEN)	L	H
H	L	L	L	L
L	H	L	L	L

AL      normal operation :L(output is ON)  
lock detection    :H(output is OFF)

Reference Data

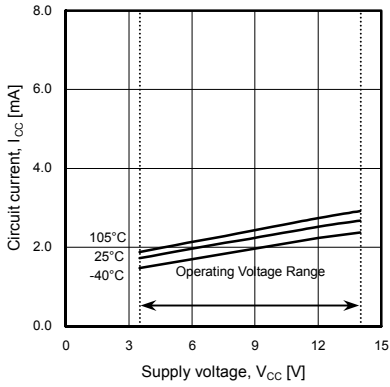

Figure 1. Circuit Current 1

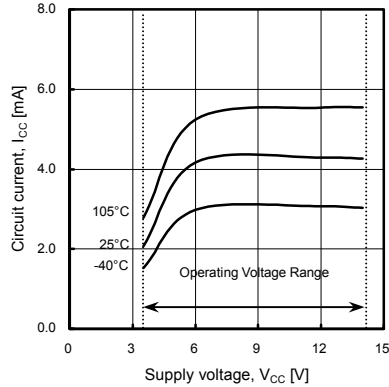

Figure 2. Circuit Current 2

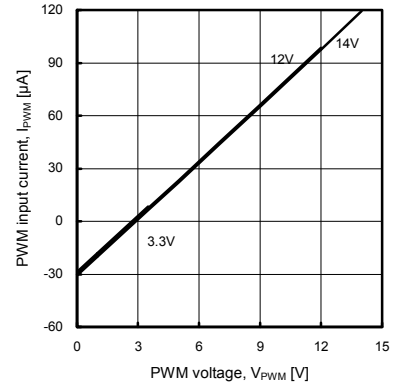

Figure 3. PWM Input Current

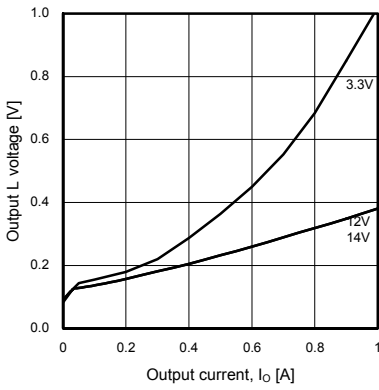

Figure 4. Output L Voltage (Voltage Characteristics)

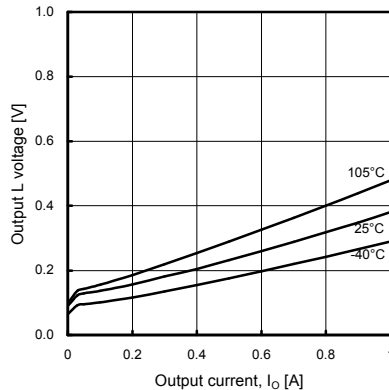

Figure 5. Output L Voltage (Temperature Characteristics)

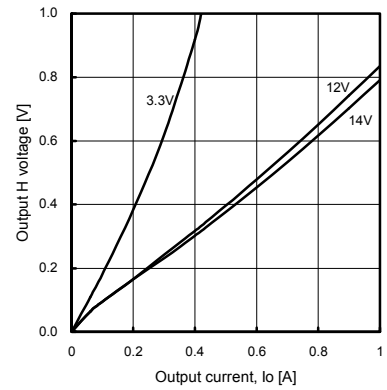

Figure 6. Output H Voltage (Voltage Characteristics)

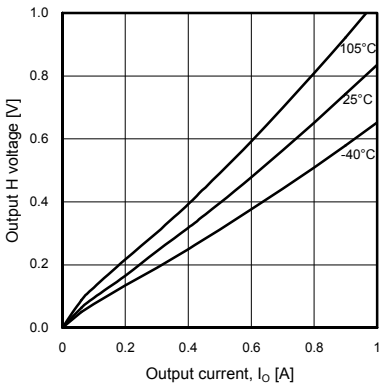

Figure 7. Output H Voltage (Temperature Characteristics)

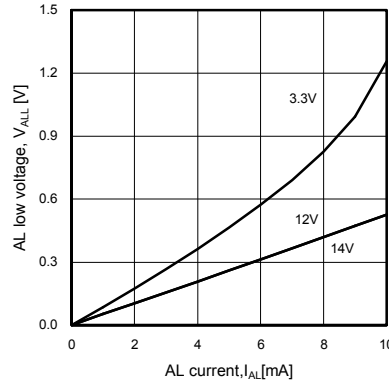

Figure 8. AL L Voltage (Voltage Characteristics)

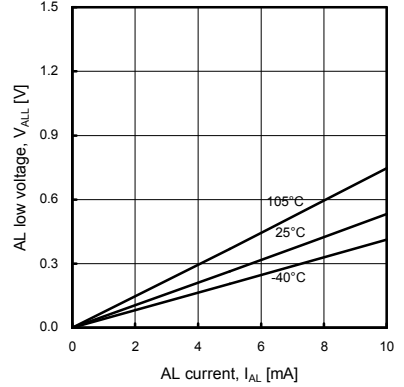

Figure 9. AL L Voltage (Temperature Characteristics)

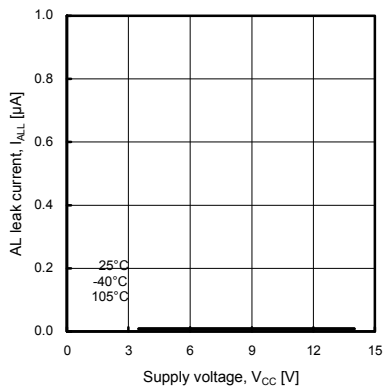

Figure 10. AL Leak Current

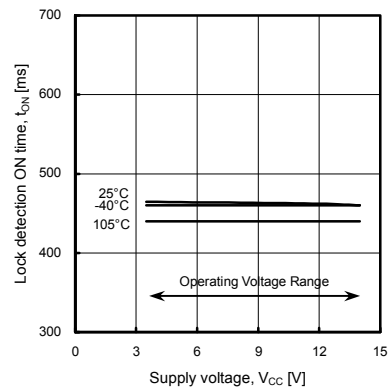

Figure 11. Lock Detection ON time

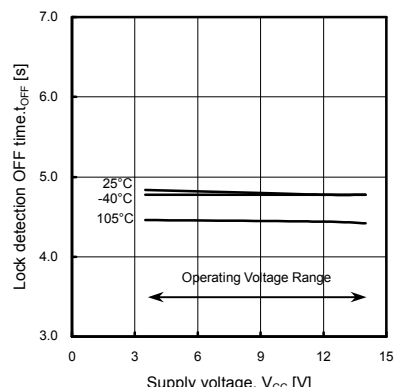
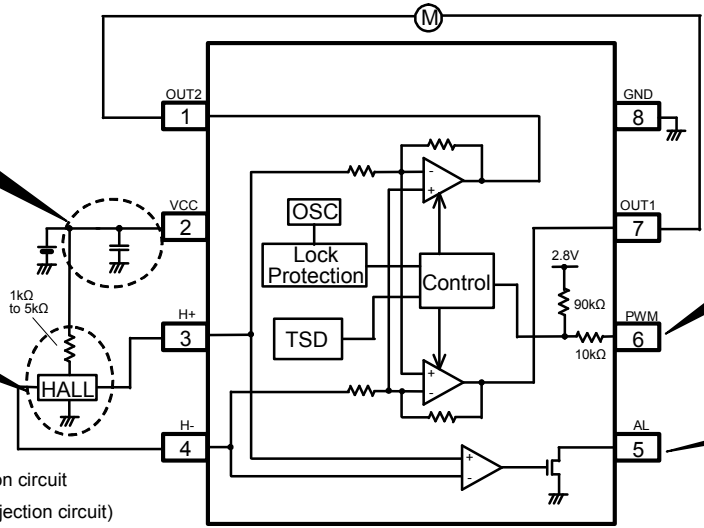

Figure 12. Lock Detection OFF Time

Block Diagram, Application Circuit, and Pin Assignment

Take a measure against Vcc voltage rise due to reverse connection of power supply and back electromotive force.  
P.8

Incorporates soft switching function. Adjust at an optimum value because gradient of switching of output waveform depends on hall element output.  
P.5



Speed control by PWM input is enabled. Input frequency must be 50kHz at the maximum.  
P.6

This is an open drain output. Connect a pull-up resistor.  
P.9

OSC : Internal reference oscillation circuit  
TSD : Thermal shutdown(head rejection circuit)

Pin No.	Pin Name	Function
1	OUT2	Motor output
2	VCC	Power supply
3	H+	Hall input +
4	H-	Hall input -
5	AL	Lock alarm signal output
6	PWM	PWM signal input
7	OUT1	Motor output
8	GND	GND

**Description of Operations**

1) Lock Protection and Automatic Restart Circuit

Motor rotation is detected by hall signal, and lock detection ON time ( $t_{ON}$ ) and lock detection OFF time ( $t_{OFF}$ ) are set by IC internal counter. External part (C or R) is not required. Timing chart is shown in Figure 13.

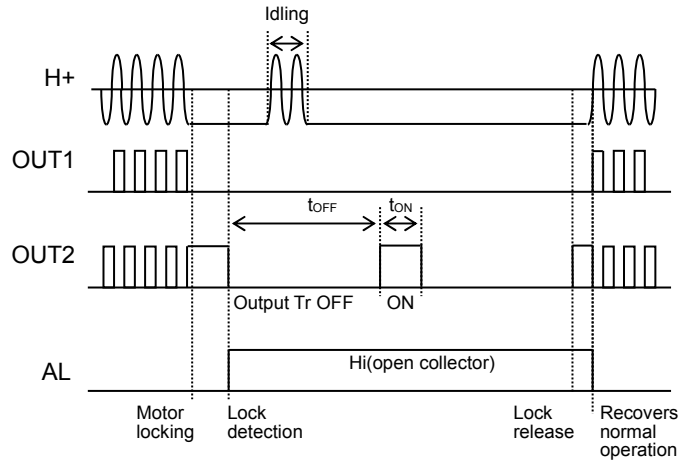

Figure 13. Lock Protection Timing Chart

2) Soft Switching (silent drive setting)

Input signal to hall amplifier is amplified to produce an output signal.

When the hall element output signal is small, the gradient of switching of output waveform is gentle; When it is large, the gradient of switching of output waveform is steep. Enter an appropriate hall element output to IC where output waveform swings sufficiently.

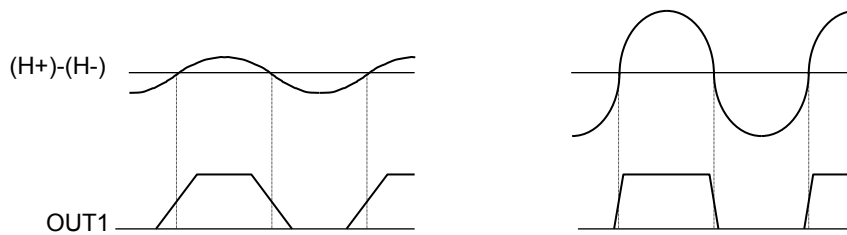

Figure 14. Relation between Hall Element Output Amplitude and Output Waveform

3) Hall Input Setting

Hall input voltage range is shown in operating conditions.

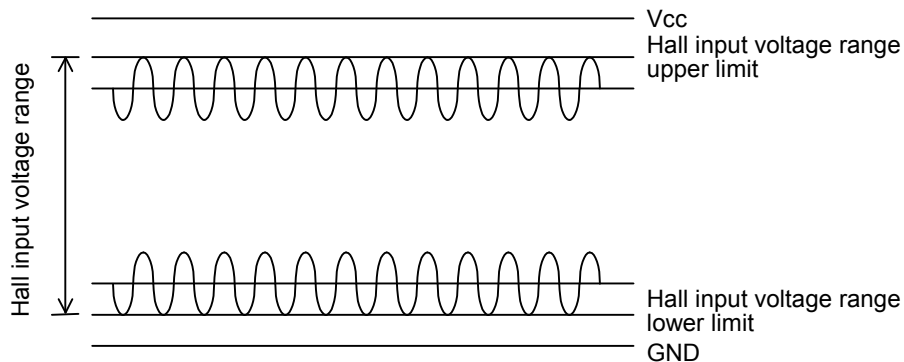

Figure 15. Hall Input Voltage Range

Adjust the value of hall element bias resistor R1 in Figure 16 so that the input voltage of a hall amplifier is input in "Hall Input Voltage Range" including signal amplitude.

○Reducing the Noise of Hall Signal

Hall element may be affected by Vcc noise depending on the wiring pattern of board. In this case, place a capacitor like C1 in Figure 16. In addition, when wiring from the hall element output to IC hall input is long, noise may be loaded on wiring. In this case, place a capacitor like C2 in Figure 16.

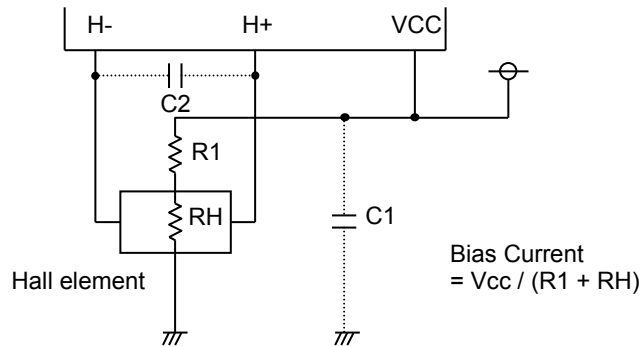

Figure 16. Application near of Hall Signal

4) PWM Input

Rotation speed of motor can be changed by controlling ON/OFF of the upper output depending on duty of the signal input to PWM terminal.

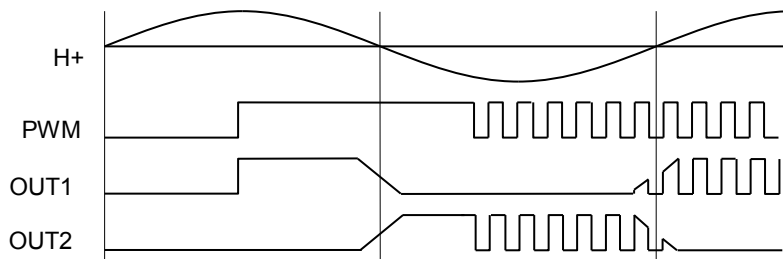

Figure 17. Timing Chart in PWM Control

When the voltage input to PWM terminal applies H logic : normal operation  
L logic : H side output is off

When PWM terminal is open, H logic is applied. PWM terminal has hysteresis of 100mV (Typ.).

\*If H logic is applied to PWM terminal before VCC voltage is applied to IC, current flows to VCC terminal through ESD protection diode inside PWM terminal, resulting in malfunction may possibly occur.  
When VCC voltage is not apply to IC, do not apply voltage to PWM terminal.

5) Quick Start, Stand-by Function

The function can start motor at once regardless of the detection time of lock protection function when the PWM signal is input. Lock protection function is turned off when the time of PWM = L has elapsed more than 66.5 ms in order to disable lock protection function when the motor is stopped by PWM signal.

When H level duty of PWM input signal is close to 0%, lock protection function does not work at an input frequency slower than 15Hz, therefore enter a frequency faster than 20Hz.

Equivalent Circuit

1) Hall Input

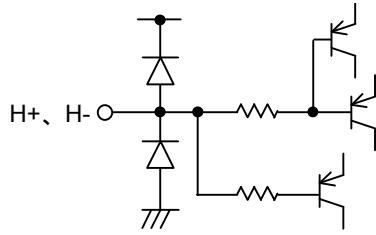

2) Motor Output

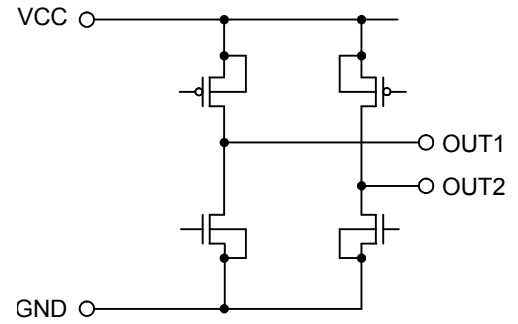

3) PWM Signal Input

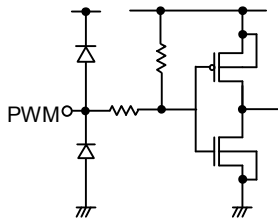

4) AL Output

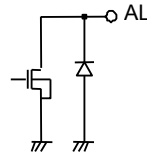

**Safety Measure**

1) Reverse Connection Protection Diode

Reverse connection of power results in IC destruction as shown in Figure 18. When reverse connection is possible, reverse connection destruction preventive diode must be added between power supply and VCC.

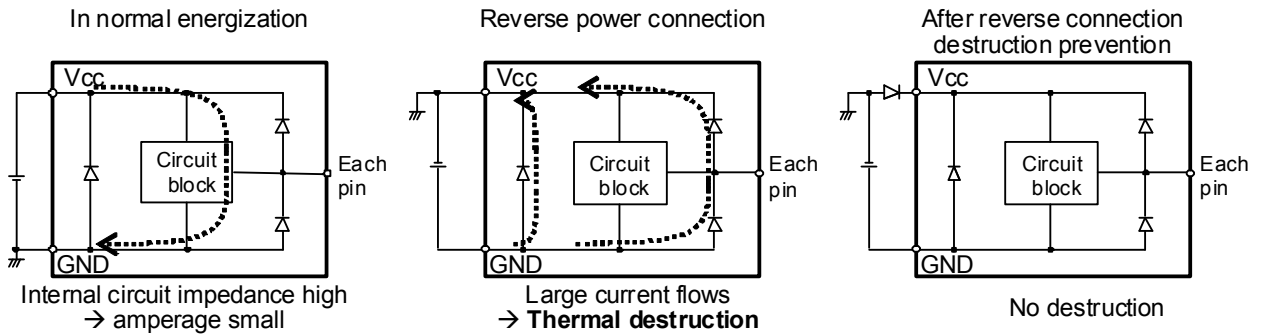

Figure 18. Flow of Current when Power is Connected Reverse

2) Measure against VCC voltage Rise by Back Electromotive Force

Back electromotive force (Back EMF) generates regenerative current to power supply. However, when reverse connection protection diode is connected, VCC voltage rises because the diode prevents current flow to power supply.

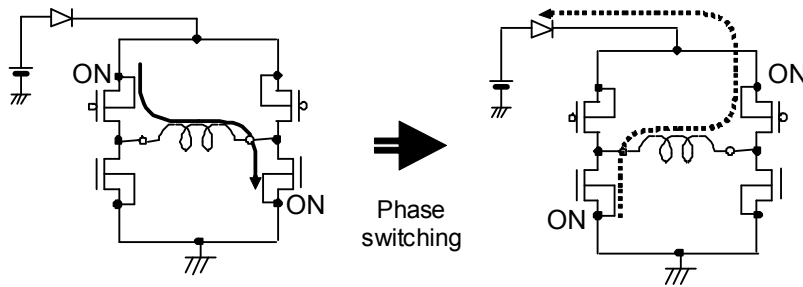

Figure 19. VCC Voltage Rise by Back Electromotive Force

When the absolute maximum rated voltage may be exceeded due to voltage rise by back electromotive force, place (A) Capacitor or (B) Zener diode between VCC and GND. If necessary, add both (C).

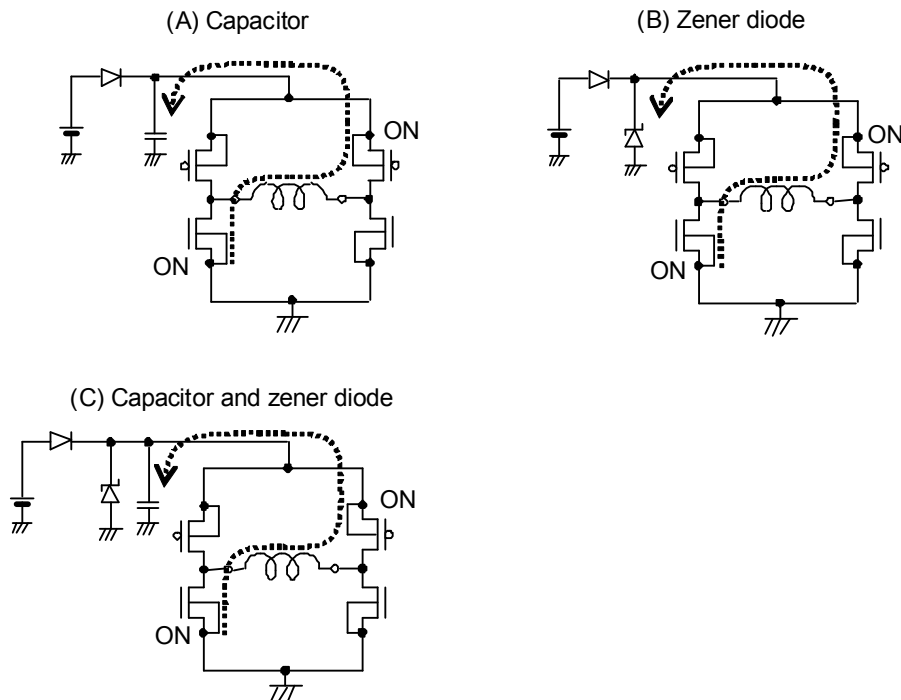

Figure 20. Measure against VCC voltage rise



3) Problem of GND Line PWM Switching

Do not perform PWM switching of GND line because the potential of GND terminal cannot be kept at the minimum.

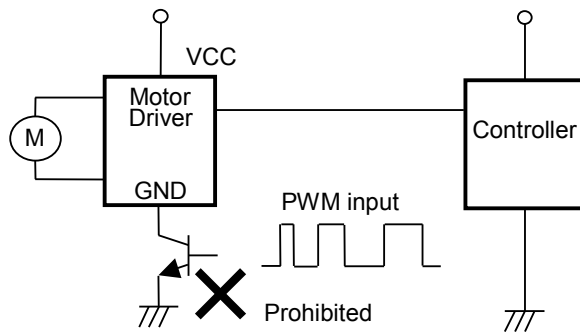

Figure 21. GND Line PWM Switching Prohibited

4) AL Output

AL output is an open drain and requires pull-up resistor.

The IC can be protected by adding resistor R1. An excess of absolute maximum rating, when AL output terminal is directly connected to power supply, could damage the IC.

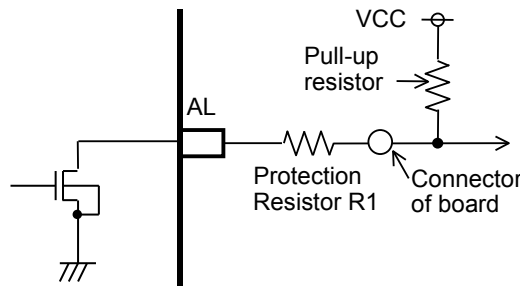
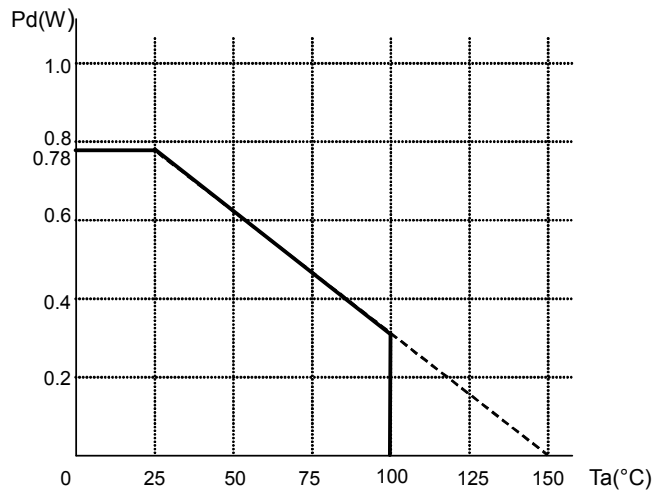

Fig.22 Protection of AL terminal

**Thermal derating curve**

Thermal derating curve indicates power that can be consumed by IC with reference to ambient temperature. Power that can be consumed by IC begins to attenuate at certain ambient temperature. This gradient is determined by thermal resistance  $\theta_{ja}$ .

Thermal resistance  $\theta_{ja}$  depends on chip size, power consumption, package ambient temperature, packaging condition, wind velocity, etc., even when the same package is used. Thermal derating curve indicates a reference value measured at a specified condition. Figure 23 shows a thermal derating curve.



\* Reduce by 6.24 mW/°C over 25°C.  
(70.0mm x 70.0mm x 1.6mm glass epoxy board)

Figure 23. Thermal Derating Curve

## Operational Notes

### 1. Reverse Connection of Power Supply

Connecting the power supply in reverse polarity can damage the IC. Take precautions against reverse polarity when connecting the power supply, such as mounting an external diode between the power supply and the IC's power supply pins.

### 2. Power Supply Lines

Design the PCB layout pattern to provide low impedance supply lines. Separate the ground and supply lines of the digital and analog blocks to prevent noise in the ground and supply lines of the digital block from affecting the analog block. Furthermore, connect a capacitor to ground at all power supply pins. Consider the effect of temperature and aging on the capacitance value when using electrolytic capacitors.

### 3. Ground Voltage

Ensure that no pins are at a voltage below that of the ground pin at any time, even during transient condition. However, pins that drive inductive loads (e.g. motor driver outputs, DC-DC converter outputs) may inevitably go below ground due to back EMF or electromotive force. In such cases, the user should make sure that such voltages going below ground will not cause the IC and the system to malfunction by examining carefully all relevant factors and conditions such as motor characteristics, supply voltage, operating frequency and PCB wiring to name a few.

### 4. Ground Wiring Pattern

When using both small-signal and large-current ground traces, the two ground traces should be routed separately but connected to a single ground at the reference point of the application board to avoid fluctuations in the small-signal ground caused by large currents. Also ensure that the ground traces of external components do not cause variations on the ground voltage. The ground lines must be as short and thick as possible to reduce line impedance.

### 5. Thermal Consideration

Should by any chance the power dissipation rating be exceeded the rise in temperature of the chip may result in deterioration of the properties of the chip. The absolute maximum rating of the Pd stated in this specification is when the IC is mounted on a 70mm x 70mm x 1.6mm glass epoxy board. In case of exceeding this absolute maximum rating, increase the board size and copper area to prevent exceeding the Pd rating.

### 6. Recommended Operating Conditions

These conditions represent a range within which the expected characteristics of the IC can be approximately obtained. The electrical characteristics are guaranteed under the conditions of each parameter.

### 7. Inrush Current

When power is first supplied to the IC, it is possible that the internal logic may be unstable and inrush current may flow instantaneously due to the internal powering sequence and delays, especially if the IC has more than one power supply. Therefore, give special consideration to power coupling capacitance, power wiring, width of ground wiring, and routing of connections.

### 8. Operation Under Strong Electromagnetic Field

Operating the IC in the presence of a strong electromagnetic field may cause the IC to malfunction.

### 9. Testing on Application Boards

When testing the IC on an application board, connecting a capacitor directly to a low-impedance output pin may subject the IC to stress. Always discharge capacitors completely after each process or step. The IC's power supply should always be turned off completely before connecting or removing it from the test setup during the inspection process. To prevent damage from static discharge, ground the IC during assembly and use similar precautions during transport and storage.

### 10. Inter-pin Short and Mounting Errors

Ensure that the direction and position are correct when mounting the IC on the PCB. Incorrect mounting may result in damaging the IC. Avoid nearby pins being shorted to each other especially to ground, power supply and output pin. Inter-pin shorts could be due to many reasons such as metal particles, water droplets (in very humid environment) and unintentional solder bridge deposited in between pins during assembly to name a few.

## Operational Notes – continued

**11. Unused Input Pins**

Input pins of an IC are often connected to the gate of a MOS transistor. The gate has extremely high impedance and extremely low capacitance. If left unconnected, the electric field from the outside can easily charge it. The small charge acquired in this way is enough to produce a significant effect on the conduction through the transistor and cause unexpected operation of the IC. So unless otherwise specified, unused input pins should be connected to the power supply or ground line.

**12. Regarding the Input Pin of the IC**

This monolithic IC contains P+ isolation and P substrate layers between adjacent elements in order to keep them isolated. P-N junctions are formed at the intersection of the P layers with the N layers of other elements, creating a parasitic diode or transistor. For example (refer to figure below):

When  $GND > Pin A$  and  $GND > Pin B$ , the P-N junction operates as a parasitic diode.  
When  $GND > Pin B$ , the P-N junction operates as a parasitic transistor.

Parasitic diodes inevitably occur in the structure of the IC. The operation of parasitic diodes can result in mutual interference among circuits, operational faults, or physical damage. Therefore, conditions that cause these diodes to operate, such as applying a voltage lower than the GND voltage to an input pin (and thus to the P substrate) should be avoided.

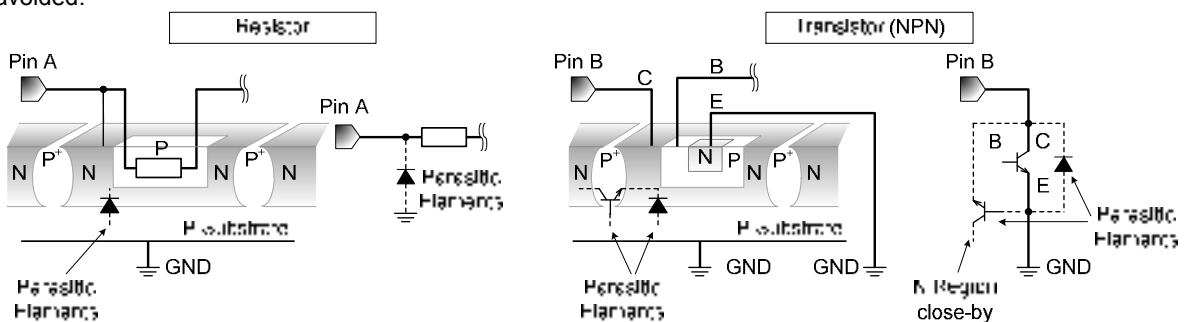

Figure 24. Example of monolithic IC structure

**13. Ceramic Capacitor**

When using a ceramic capacitor, determine the dielectric constant considering the change of capacitance with temperature and the decrease in nominal capacitance due to DC bias and others.

**14. Thermal Shutdown Circuit(TSD)**

This IC has a built-in thermal shutdown circuit that prevents heat damage to the IC. Normal operation should always be within the IC's power dissipation rating. If however the rating is exceeded for a continued period, the junction temperature ( $T_j$ ) will rise which will activate the TSD circuit that will turn OFF all output pins. When the  $T_j$  falls below the TSD threshold, the circuits are automatically restored to normal operation.

Note that the TSD circuit operates in a situation that exceeds the absolute maximum ratings and therefore, under no circumstances, should the TSD circuit be used in a set design or for any purpose other than protecting the IC from heat damage.

Ordering Information

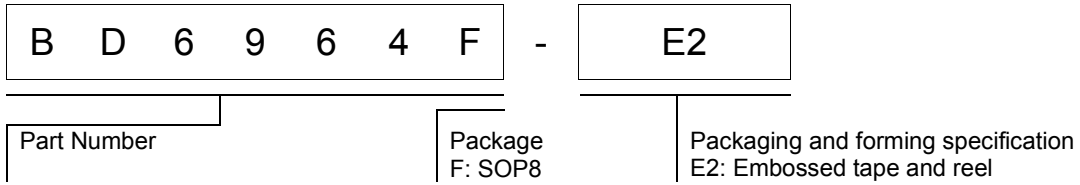

Marking Diagram

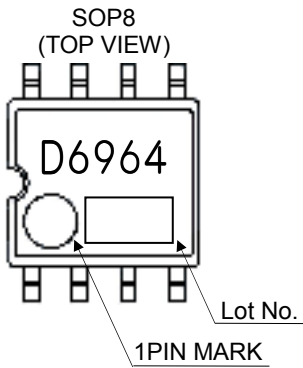

Physical Dimension, Tape and Reel Information

Package Name	SOP8
--------------	------

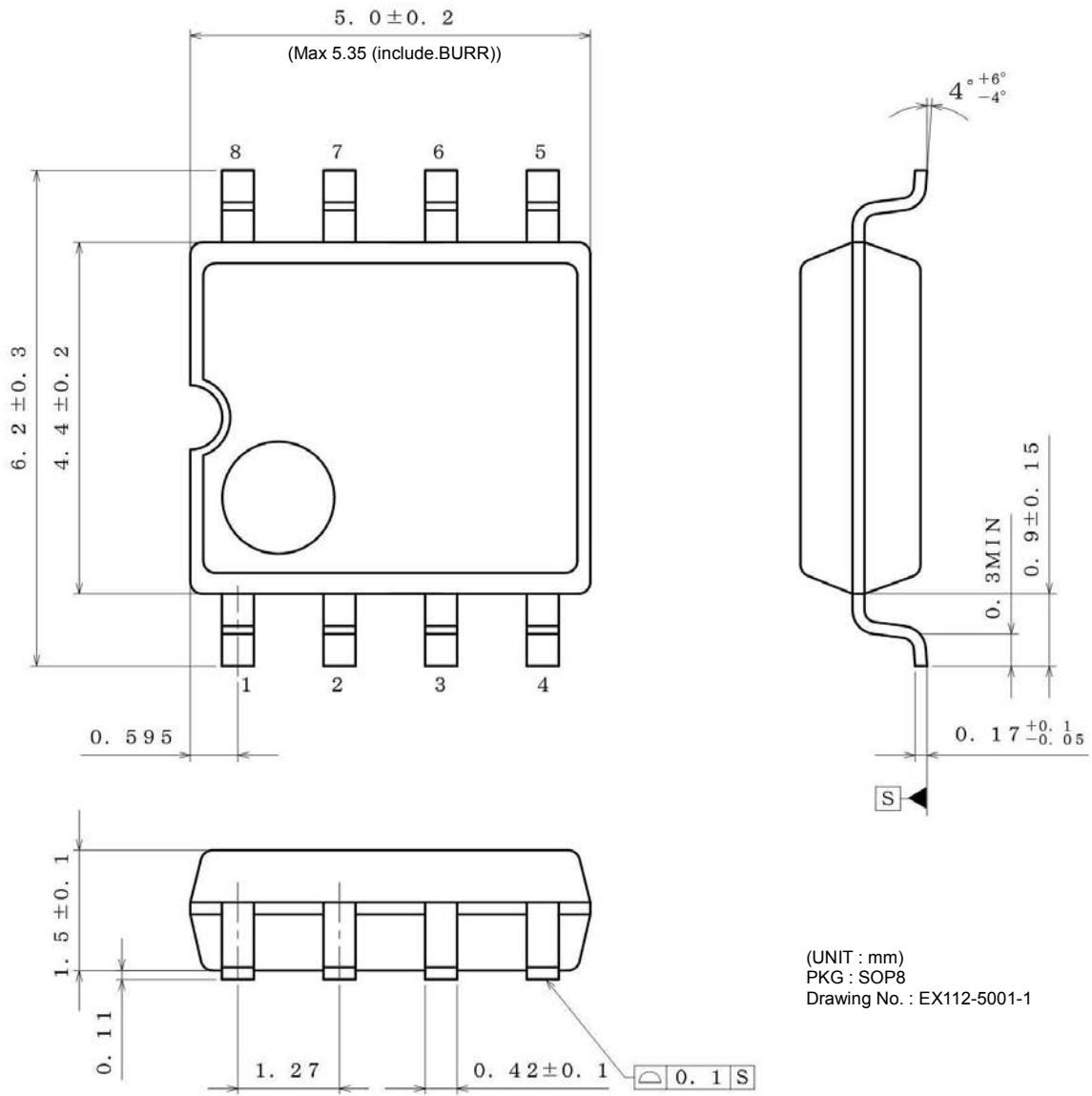

(UNIT : mm)  
 PKG : SOP8  
 Drawing No. : EX112-5001-1

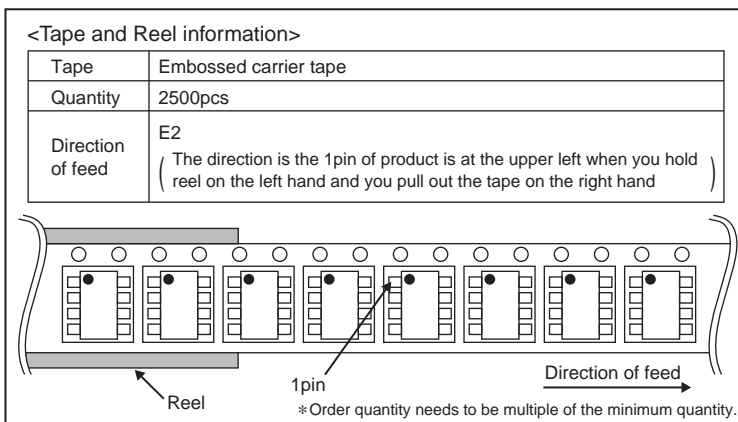

# Notice

## Precaution on using ROHM Products

- Our Products are designed and manufactured for application in ordinary electronic equipments (such as AV equipment, OA equipment, telecommunication equipment, home electronic appliances, amusement equipment, etc.). If you intend to use our Products in devices requiring extremely high reliability (such as medical equipment <sup>(Note 1)</sup>, transport equipment, traffic equipment, aircraft/spacecraft, nuclear power controllers, fuel controllers, car equipment including car accessories, safety devices, etc.) and whose malfunction or failure may cause loss of human life, bodily injury or serious damage to property ("Specific Applications"), please consult with the ROHM sales representative in advance. Unless otherwise agreed in writing by ROHM in advance, ROHM shall not be in any way responsible or liable for any damages, expenses or losses incurred by you or third parties arising from the use of any ROHM's Products for Specific Applications.

(Note1) Medical Equipment Classification of the Specific Applications

JAPAN	USA	EU	CHINA
CLASS III	CLASS III	CLASS II b	CLASS III
CLASS IV		CLASS III	

- ROHM designs and manufactures its Products subject to strict quality control system. However, semiconductor products can fail or malfunction at a certain rate. Please be sure to implement, at your own responsibilities, adequate safety measures including but not limited to fail-safe design against the physical injury, damage to any property, which a failure or malfunction of our Products may cause. The following are examples of safety measures:
  - Installation of protection circuits or other protective devices to improve system safety
  - Installation of redundant circuits to reduce the impact of single or multiple circuit failure
- Our Products are designed and manufactured for use under standard conditions and not under any special or extraordinary environments or conditions, as exemplified below. Accordingly, ROHM shall not be in any way responsible or liable for any damages, expenses or losses arising from the use of any ROHM's Products under any special or extraordinary environments or conditions. If you intend to use our Products under any special or extraordinary environments or conditions (as exemplified below), your independent verification and confirmation of product performance, reliability, etc. prior to use, must be necessary:
  - Use of our Products in any types of liquid, including water, oils, chemicals, and organic solvents
  - Use of our Products outdoors or in places where the Products are exposed to direct sunlight or dust
  - Use of our Products in places where the Products are exposed to sea wind or corrosive gases, including Cl<sub>2</sub>, H<sub>2</sub>S, NH<sub>3</sub>, SO<sub>2</sub>, and NO<sub>2</sub>
  - Use of our Products in places where the Products are exposed to static electricity or electromagnetic waves
  - Use of our Products in proximity to heat-producing components, plastic cords, or other flammable items
  - Sealing or coating our Products with resin or other coating materials
  - Use of our Products without cleaning residue of flux (even if you use no-clean type fluxes, cleaning residue of flux is recommended); or Washing our Products by using water or water-soluble cleaning agents for cleaning residue after soldering
  - Use of the Products in places subject to dew condensation
- The Products are not subject to radiation-proof design.
- Please verify and confirm characteristics of the final or mounted products in using the Products.
- In particular, if a transient load (a large amount of load applied in a short period of time, such as pulse. is applied, confirmation of performance characteristics after on-board mounting is strongly recommended. Avoid applying power exceeding normal rated power; exceeding the power rating under steady-state loading condition may negatively affect product performance and reliability.
- De-rate Power Dissipation (Pd) depending on Ambient temperature (Ta). When used in sealed area, confirm the actual ambient temperature.
- Confirm that operation temperature is within the specified range described in the product specification.
- ROHM shall not be in any way responsible or liable for failure induced under deviant condition from what is defined in this document.

## Precaution for Mounting / Circuit board design

- When a highly active halogenous (chlorine, bromine, etc.) flux is used, the residue of flux may negatively affect product performance and reliability.
- In principle, the reflow soldering method must be used; if flow soldering method is preferred, please consult with the ROHM representative in advance.

For details, please refer to ROHM Mounting specification

### Precautions Regarding Application Examples and External Circuits

1. If change is made to the constant of an external circuit, please allow a sufficient margin considering variations of the characteristics of the Products and external components, including transient characteristics, as well as static characteristics.
2. You agree that application notes, reference designs, and associated data and information contained in this document are presented only as guidance for Products use. Therefore, in case you use such information, you are solely responsible for it and you must exercise your own independent verification and judgment in the use of such information contained in this document. ROHM shall not be in any way responsible or liable for any damages, expenses or losses incurred by you or third parties arising from the use of such information.

### Precaution for Electrostatic

This Product is electrostatic sensitive product, which may be damaged due to electrostatic discharge. Please take proper caution in your manufacturing process and storage so that voltage exceeding the Products maximum rating will not be applied to Products. Please take special care under dry condition (e.g. Grounding of human body / equipment / solder iron, isolation from charged objects, setting of Ionizer, friction prevention and temperature / humidity control).

### Precaution for Storage / Transportation

1. Product performance and soldered connections may deteriorate if the Products are stored in the places where:
  - [a] the Products are exposed to sea winds or corrosive gases, including Cl<sub>2</sub>, H<sub>2</sub>S, NH<sub>3</sub>, SO<sub>2</sub>, and NO<sub>2</sub>
  - [b] the temperature or humidity exceeds those recommended by ROHM
  - [c] the Products are exposed to direct sunshine or condensation
  - [d] the Products are exposed to high Electrostatic
2. Even under ROHM recommended storage condition, solderability of products out of recommended storage time period may be degraded. It is strongly recommended to confirm solderability before using Products of which storage time is exceeding the recommended storage time period.
3. Store / transport cartons in the correct direction, which is indicated on a carton with a symbol. Otherwise bent leads may occur due to excessive stress applied when dropping of a carton.
4. Use Products within the specified time after opening a humidity barrier bag. Baking is required before using Products of which storage time is exceeding the recommended storage time period.

### Precaution for Product Label

QR code printed on ROHM Products label is for ROHM's internal use only.

### Precaution for Disposition

When disposing Products please dispose them properly using an authorized industry waste company.

### Precaution for Foreign Exchange and Foreign Trade act

Since our Products might fall under controlled goods prescribed by the applicable foreign exchange and foreign trade act, please consult with ROHM representative in case of export.

### Precaution Regarding Intellectual Property Rights

1. All information and data including but not limited to application example contained in this document is for reference only. ROHM does not warrant that foregoing information or data will not infringe any intellectual property rights or any other rights of any third party regarding such information or data. ROHM shall not be in any way responsible or liable for infringement of any intellectual property rights or other damages arising from use of such information or data.:
2. No license, expressly or implied, is granted hereby under any intellectual property rights or other rights of ROHM or any third parties with respect to the information contained in this document.

### Other Precaution

1. This document may not be reprinted or reproduced, in whole or in part, without prior written consent of ROHM.
2. The Products may not be disassembled, converted, modified, reproduced or otherwise changed without prior written consent of ROHM.
3. In no event shall you use in any way whatsoever the Products and the related technical information contained in the Products or this document for any military purposes, including but not limited to, the development of mass-destruction weapons.
4. The proper names of companies or products described in this document are trademarks or registered trademarks of ROHM, its affiliated companies or third parties.

### General Precaution

1. Before you use our Products, you are requested to carefully read this document and fully understand its contents. ROHM shall not be in any way responsible or liable for failure, malfunction or accident arising from the use of any ROHM's Products against warning, caution or note contained in this document.
2. All information contained in this document is current as of the issuing date and subject to change without any prior notice. Before purchasing or using ROHM's Products, please confirm the latest information with a ROHM sales representative.
3. The information contained in this document is provided on an "as is" basis and ROHM does not warrant that all information contained in this document is accurate and/or error-free. ROHM shall not be in any way responsible or liable for any damages, expenses or losses incurred by you or third parties resulting from inaccuracy or errors of or concerning such information.