

THIS DRAWING IS UNPUBLISHED.

RELEASED FOR PUBLICATION

© COPYRIGHT - BY TYCO ELECTRONICS CORPORATION. ALL INTERNATIONAL RIGHTS RESERVED.

LDC		DIST		REVISIONS			
P	LTR	DESCRIPTION		DATE	DWN	APVD	
	D	ECR-11-017058		17AUG11	MS	TW	

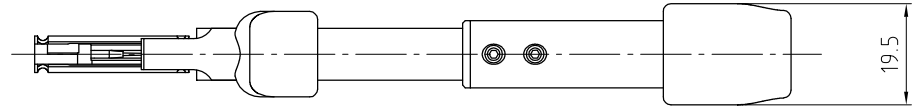
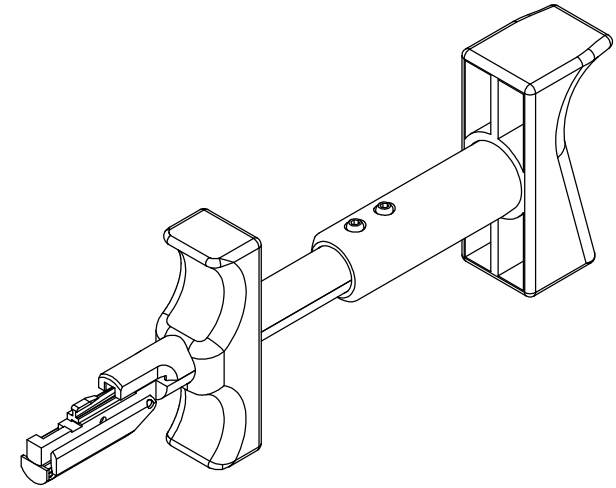
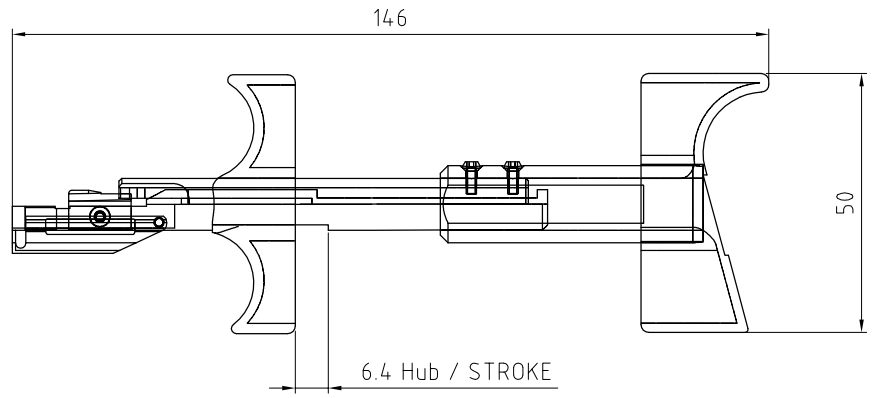

Mandrels: 655499-1 AWG26/24
 655499-2 AWG 24/24
 655499-3 AWG 22/24
 Customer manual: 411-18509

Mandrels müssen separat bestellt werden.
 Mandrels have to be ordered separately.

THIS DRAWING IS A CONTROLLED DOCUMENT.		DWN M.Strecker	23AUG11	STE TE Connectivity
DIMENSIONS: mm		CHK T.Weissgerber	23AUG11	
TOLERANCES UNLESS OTHERWISE SPECIFIED:		APVD T.Weissgerber	23AUG11	NAME
0 PLC ± -		PRODUCT SPEC		SERVICE TOOL STANDART TERMI POINT
1 PLC ± -		APPLICATION SPEC		Service Tool Standart Termi Point
2 PLC ± -		408-2019		RESTRICTED TO
3 PLC ± -		A3		SIZE
4 PLC ± -		00779		CAGE CODE
ANGLES ± -		G=655498-1		DRAWING NO
MATERIAL		CUSTOMER DRAWING		SCALE 1:1
FINISH		SHEET 1 OF 1		REV D