

REV.	ECR/ECN No.	DESCRIPTION	DRAWN/DATE	CHECKED/DATE	APPROVED/DATE
A		NEW RELEASE	JiangSM 2021-03-02	Staven 2021-03-02	Sam 2021-03-02

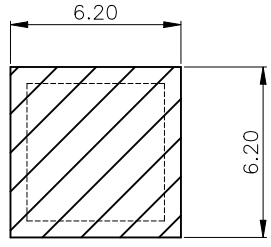
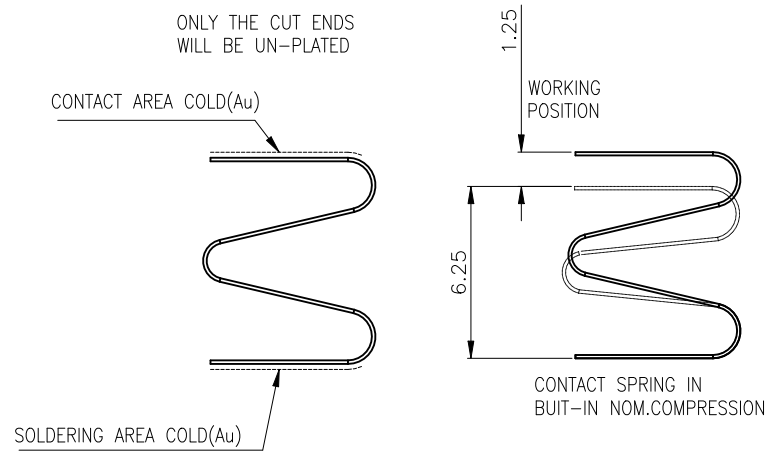

PCB LAYOUT RECOMMEND  
(TOP VIEW) TOLERANCE:±0.05

- NOTES:
- 1)MATERIALS: C5210-EH T=0.12mm.
  - 2)FINISH:GOLD FLASH SURFACE PLATING OVER CONTACT AREAS, GOLD FLASH SURFACE PLATING OVER SOLDER AREAS, Ni 40-120u" UNDER PLATING OVER ALL.
  - 3)ALLOWING BURRS 0.03mm Max.
  - 4)OPERATING TEMP: -20 to 125°C.
  - 5)THE SURFACE IS NOT ALLOWED TO HAVE CRUSHING; SCRATCH;DEFORMATION;DIE MARKS;OIL STAINS.
  - 6)""THE SYMBOL INDICATES THE DIMENSION OF KEY FUNCTION INSPECTION.

A

A

B

B

C

C

D

D

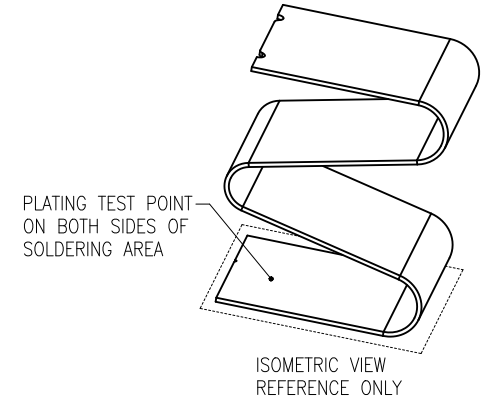
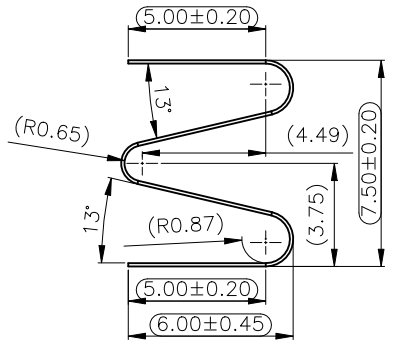
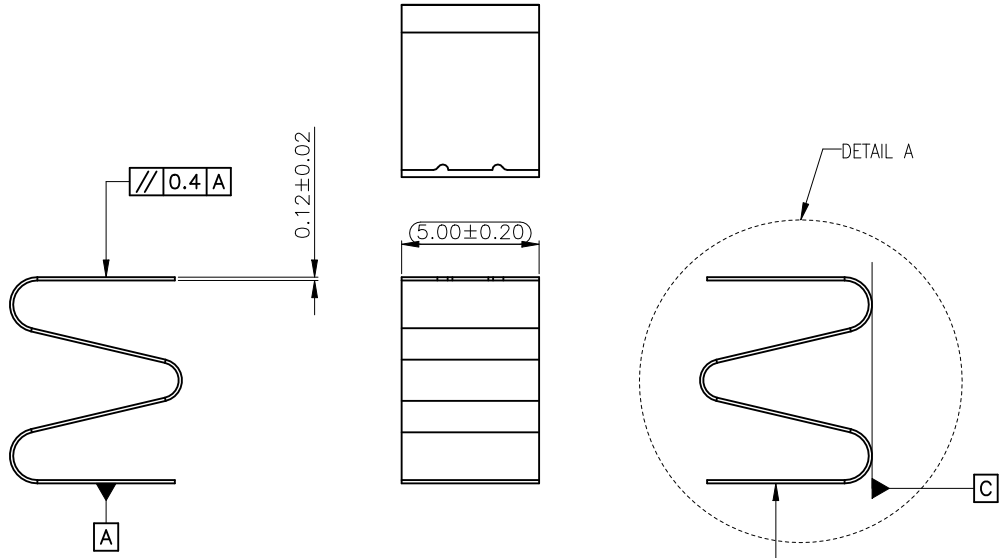

HATCH AREA REPRESENTS UN-INTERRUPTED SURFACE FOR SMT NOZZLE

UNLESS OTHERWISE SPECIFIED TOLERANCES				ANGLE OF PROJECTION		Amphenol AORORA	
X.	±0.30	X. '	± 5'			Amphenol Aorora Technology (Huizhou) Co.,Ltd	
X.X	±0.25	X.X '	± 4'				
X.XX	±0.20	X.XX '	± 3'	Customer Drw		TITLE: H7.5 SPRING	
X.XXX	±0.15	X.XXX '	± 2'	DOC TYPE	Customer Drw	SIZE	A4
LINEAR DIMS		ANGLES DIMS		DRAWN DATE	JiangSM 2021-03-02	PART NUMBER: Z02J-4F7L1-11000	
DWG NO.: A-S0653				DESIGN DATE	JiangSM 2021-03-02	REV.	A
MATERIAL		SEE NOTES		CHECKED DATE	Staven 2021-03-02	SCALE	1:1
FINISHED		SEE NOTES		APPROVED DATE	Sam 2021-03-02	UNIT : mm	SHEET 1 OF 1

This document is the property of and embodies CONFIDENTIAL and PROPRIETARY information of AOR. No part of the information shown on this document may be used in any way or disclosed to others without the written consent of AOR. © 2019 AOR



This document is the property of and embodies CONFIDENTIAL and PROPRIETARY information of AORORA. No part of the information shown on this document may be used in any way or disclosed to others without the written consent of AORORA. © 2019 AORORA



REV.	ECR/ECN No.	DESCRIPTION	DRAWN/DATE	CHECKED/DATE	APPROVED/DATE
A	ECN2021064	FORMAL VERSION RELEASE	JiangSM 2021-06-23	Staven 2021-06-23	Biao 2021-06-23

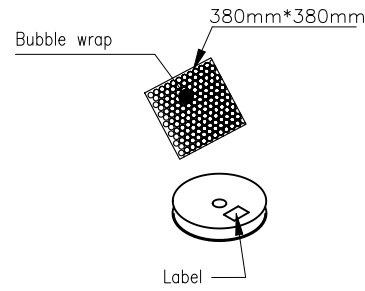
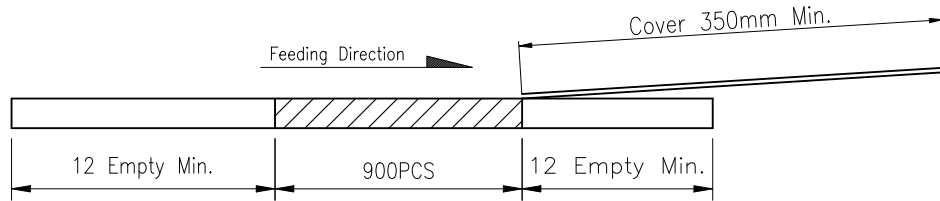
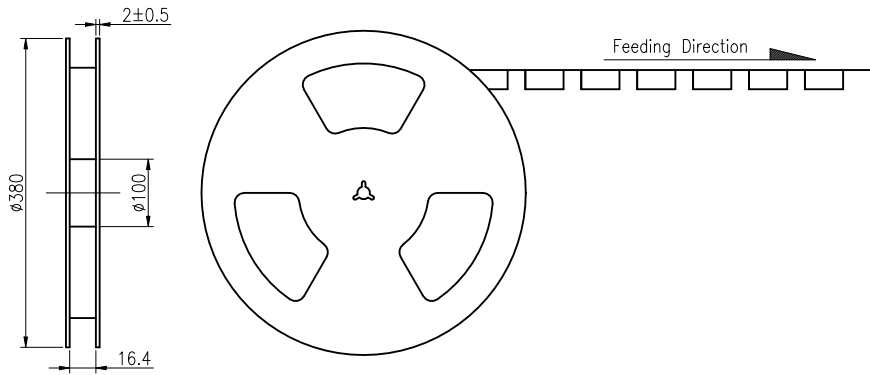
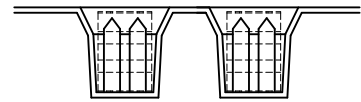
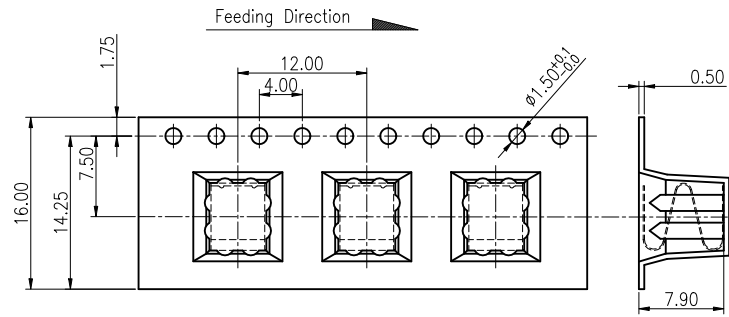

Note:

- Material:
  - 1.1 Tape:PS,T=0.5mm,Transparent
  - 1.2 Reel:HIPS,Blue
  - 1.3 Cover:PET,Transparent
- Reel Package:900PCS/Reel.
- Carton Package: 14 Reels/Carton (12600=14\*900/Carton).
- Pull-off Force: 0.2N~1.2N(20~120gf);  
 Pull-off Degree: 165°~180° ;  
 Pull-off Speed: 300mm/Minute.

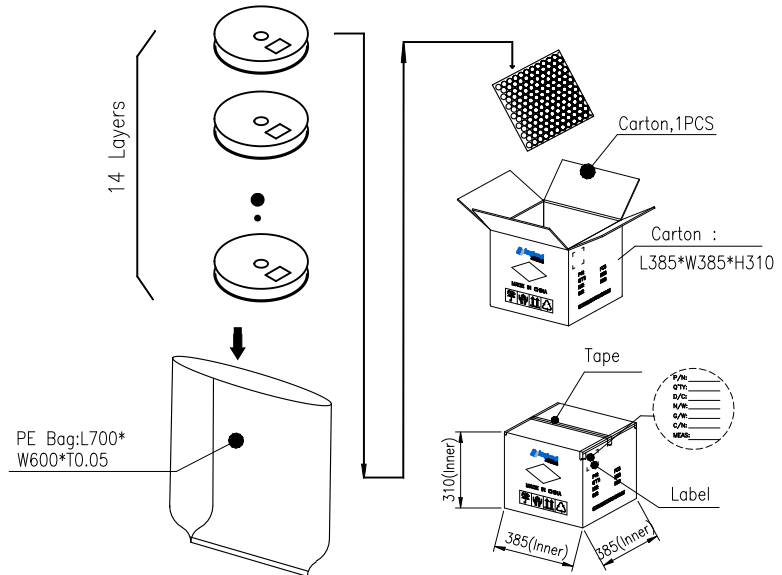

UNLESS OTHERWISE SPECIFIED TOLERANCES				ANGLE OF PROJECTION		Amphenol AORORA		
X.	±0.30	X. °	± 5'			Amphenol Aorora Technology (Huizhou) Co.,Ltd		
X.X	±0.25	X.X °	± 4'					
X.XX	±0.20	X.XX °	± 3'	DOC TYPE		TITLE:		
X.XXX	±0.15	X.XXX °	± 2'	Package Drw		H7.5 SPRING		
LINEAR DIMS	ANGLES DIMS			DRAWN	DATE	JiangSM	SIZE	
DWG NO.:	A-H0364			DESIGN	DATE	JiangSM		PART NUMBER
MATERIAL	SEE NOTES			CHECKED	DATE	Staven	Z02J-4F7L1-11000	
FINISHED	SEE NOTES			APPROVED	DATE	Biao		REV.
				2021-06-23		A4		SCALE
						1:1		UNIT : mm
						SHEET		1 OF 1