

HA17901 Series

Quadruple Comparators

REJ03D0684-0100
(Previous: ADE-204-047)
Rev.1.00
Jun 15, 2005

Description

The HA17901 series products are comparators designed for use in power or control systems.

These IC operate from a single power-supply voltage over a wide range of voltages, and feature a reduced power-supply current since the power-supply voltage is determined independently.

These comparators have the unique characteristic of ground being included in the common-mode input voltage range, even when operating from a single-voltage power supply. These products have a wide range of applications, including limit comparators, simple A/D converters, pulse/square-wave/time delay generators, wide range VCO circuits, MOS clock timers, multivibrators, and high-voltage logic gates.

Features

- Wide power-supply voltage range: 2 to 36V
- Extremely low current drain: 0.8mA
- Low input bias current: 25nA
- Low input offset current: 5nA
- Low input offset voltage: 2mV
- The common-mode input voltage range includes ground.
- Low output saturation voltage: 1mV (5 μ A), 70mV (1mA)
- Output voltages compatible with CMOS logic systems

Ordering Information

Type No.	Application	Package Code (Previous Code)
HA17901PJ	Car use	PRDP0014AB-A (DP-14)
HA17901FPJ		PRSP0014DF-B (FP-14DAV)
HA17901FPK		PRSP0014DF-B (FP-14DAV)

Pin Arrangement

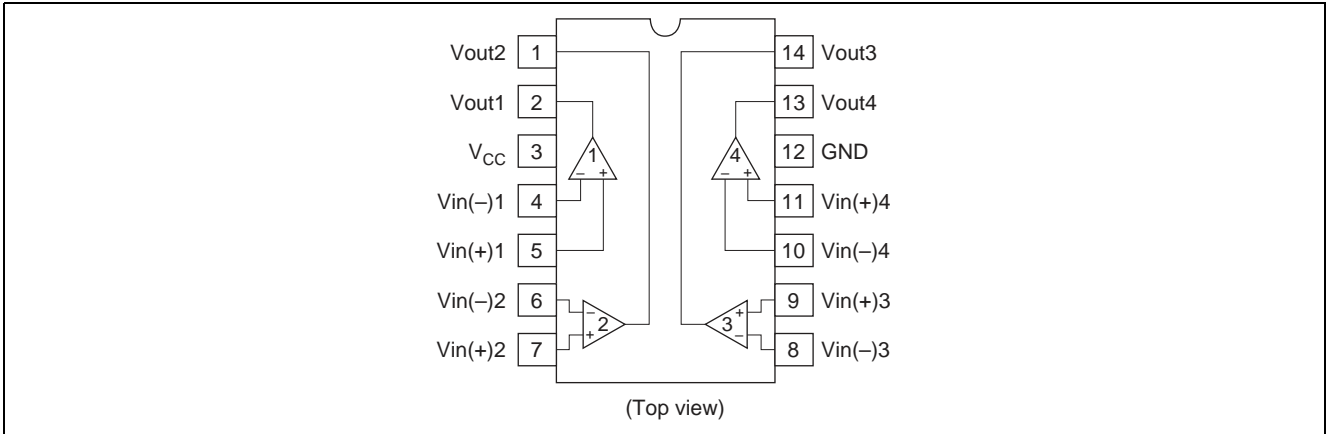

Circuit Structure (1/4)

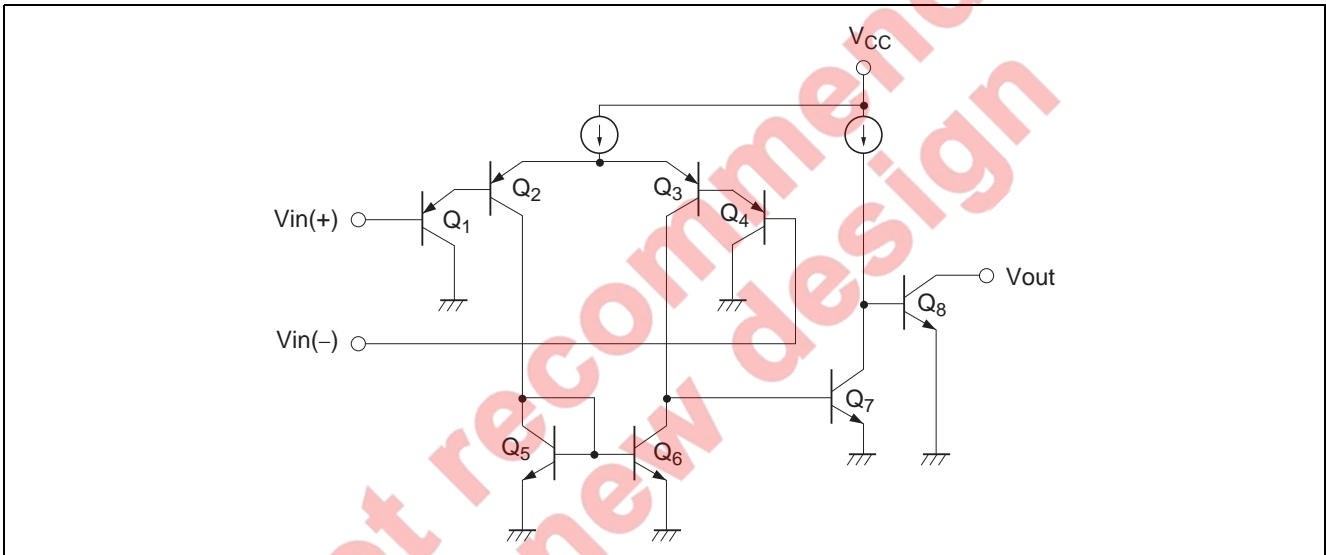

Absolute Maximum Ratings

(Ta = 25°C)

Item	Symbol	17901PJ	17901FPJ	17901FPK	Unit
Power-supply voltage	V _{CC}	36	36	36	V
Differential input voltage	V _{in(diff)}	±V _{CC}	±V _{CC}	±V _{CC}	V
Input voltage	V _{in}	-0.3 to +V _{CC}	-0.3 to +V _{CC}	-0.3 to +V _{CC}	V
Output current	I _{out} * ²	20	20	20	mA
Allowable power dissipation	P _T	625* ¹	625* ³	625* ³	mW
Operating temperature	Topr	-40 to +85	-40 to +85	-40 to +125	°C
Storage temperature	Tstg	-55 to +125	-55 to +125	-55 to +150	°C
Output pin voltage	V _{out}	36	36	36	V

- Notes: 1. These are the allowable values up to Ta = 50°C. Derate by 8.3mW/°C above that temperature.
 2. These products can be destroyed if the output and V_{CC} are shorted together. The maximum output current is the allowable value for continuous operation.
 3. See notes of SOP Package Usage in Reliability section.

Electrical Characteristics 1

(V_{CC} = 5V, Ta = 25°C)

Item	Symbol	Min	Typ	Max	Unit	Test Condition
Input offset voltage	V _{IO}	—	2	7	mV	Output switching point: when V _O = 1.4V, R _S = 0Ω
Input bias current	I _{IB}	—	25	250	nA	I _{IN(+)} or I _{IN(-)}
Input offset current	I _{IO}	—	5	50	nA	I _{IN(+)} - I _{IN(-)}
Common-mode input voltage* ¹	V _{CM}	0	—	V _{CC} - 1.5	V	
Supply current	I _{CC}	—	0.8	2	mA	R _L = ∞
Voltage Gain	A _{VD}	—	200	—	V/mV	R _L = 15kΩ
Response time* ²	t _R	—	1.3	—	μs	V _{RL} = 5V, R _L = 5.1kΩ
Output sink current	I _{osink}	6	16	—	mA	V _{IN(-)} = 1V, V _{IN(+)} = 0, V _O ≤ 1.5V
Output saturation voltage	V _{O sat}	—	200	400	mV	V _{IN(-)} = 1V, V _{IN(+)} = 0, I _{osink} = 3mA
Output leakage current	I _{LO}	—	0.1	—	nA	V _{IN(+)} = 1V, V _{IN(-)} = 0, V _O = 5V

- Notes: 1. Voltages more negative than -0.3V are not allowed for the common-mode input voltage or for either one of the input signal voltages.
 2. The stipulated response time is the value for a 100 mV input step voltage that has a 5mV overdrive.

Electrical Characteristics 2

(V_{CC} = 5V, Ta = -41 to +125°C)

Item	Symbol	Min	Typ	Max	Unit	Test Condition
Input offset voltage	V _{IO}	—	—	7	mV	Output switching point: when V _O = 1.4V, R _S = 0Ω
Input offset current	I _{IO}	—	—	200	nA	I _{IN(-)} - I _{IN(+)}
Input bias current	I _{IB}	—	—	500	nA	
Common-mode input voltage* ¹	V _{CM}	0	—	V _{CC} - 2.0	V	
Output saturation voltage	V _{O sat}	—	—	440	mV	V _{IN(-)} ≥ 1V, V _{IN(+)} = 0, I _{osink} ≤ 4mA
Output leakage current	I _{LO}	—	1.0	—	μA	V _{IN(-)} = 0V, V _{IN(+)} ≥ 1V, V _O = 30V
Supply current	I _{CC}	—	—	4.0	mA	All comparators: R _L = ∞, All channels ON

- Note: 1. Voltages more negative than -0.3V are not allowed for the common-mode input voltage or for either one of the input signal voltages.

Test Circuits

1. Input offset voltage (V_{IO}), input offset current (I_{IO}), and Input bias current (I_{IB}) test circuit

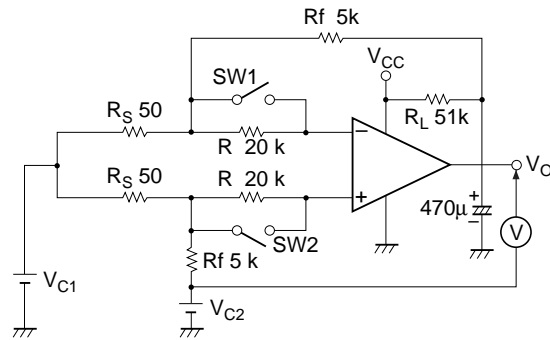

SW1	SW2	Vout
On	On	V_{O1}
Off	Off	V_{O2}
On	Off	V_{O3}
Off	On	V_{O4}

$$V_{C1} = \frac{1}{2} V_{CC}$$

$$V_{C2} = 1.4V$$

$$V_{IO} = \frac{|V_{O1}|}{1 + R_f / R_S} \quad (\text{mV})$$

$$I_{IO} = \frac{|V_{O2} - V_{O1}|}{R(1 + R_f / R_S)} \quad (\text{nA})$$

$$I_{IB} = \frac{|V_{O4} - V_{O3}|}{2 \cdot R(1 + R_f / R_S)} \quad (\text{nA})$$

2. Output saturation voltage ($V_{O sat}$) output sink current (I_{osink}), and common-mode input voltage (V_{CM}) test circuit

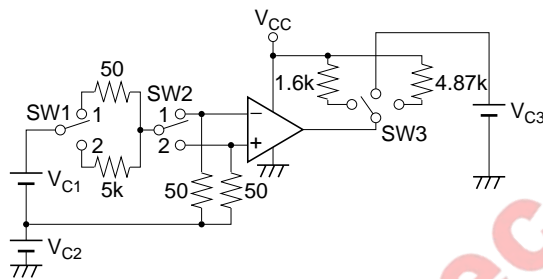

Item	V_{C1}	V_{C2}	V_{C3}	SW1	SW2	SW3	Unit
$V_{O sat}$	2V	0V	—	1	1	1 at $V_{CC} = 5V$ 3 at $V_{CC} = 15V$	V
I_{osink}	2V	0V	1.5V	1	1	2	mA
V_{CM}	2V	-1 to V_{CC}	—	2	Switched between 1 and 2	3	V

3. Supply current (I_{CC}) test circuit

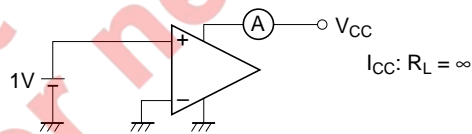

4. Voltage gain (A_{VD}) test circuit ($R_L = 15k\Omega$)

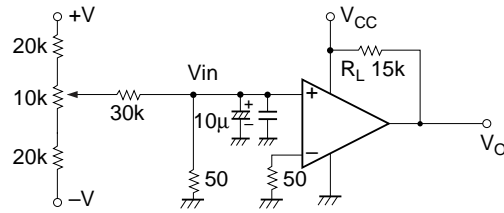

$$A_{VD} = 20 \log \frac{V_{O1} - V_{O2}}{V_{IN1} - V_{IN2}} \quad (\text{dB})$$

5. Response time (t_R) test circuit

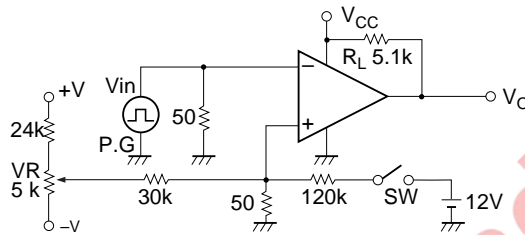

t_R : $R_L = 5.1k\Omega$, a 100mV input step voltage that has a 5mV overdrive

- With V_{IN} not applied, set the switch SW to the off position and adjust V_R so that V_O is in the vicinity of 1.4V.
- Apply V_{IN} and turn the switch SW on.

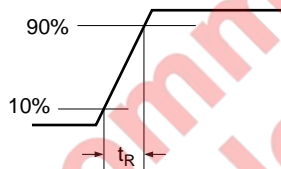

Not recommended for new design

Characteristics Curve

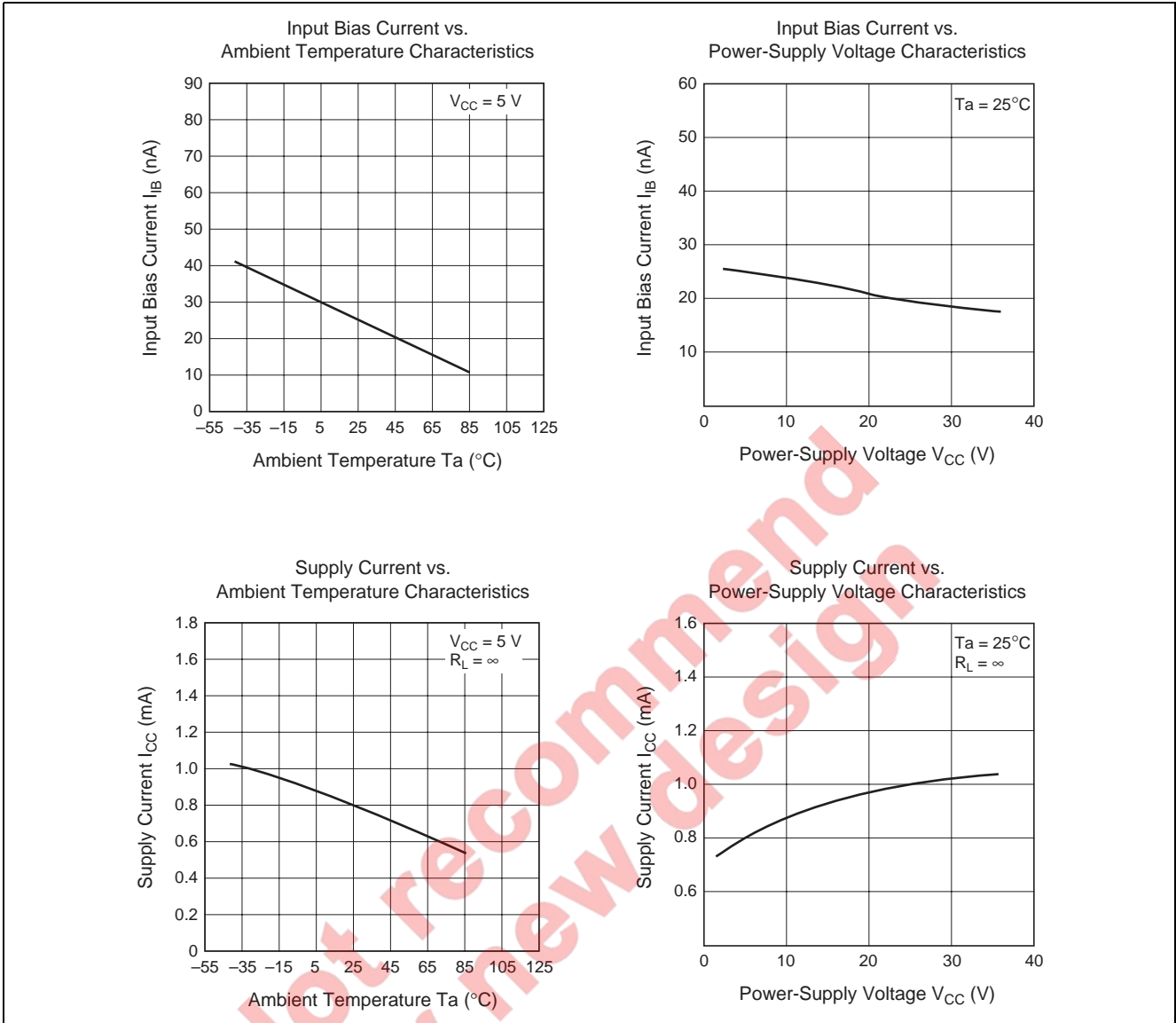

Output Sink Current vs. Ambient Temperature Characteristics

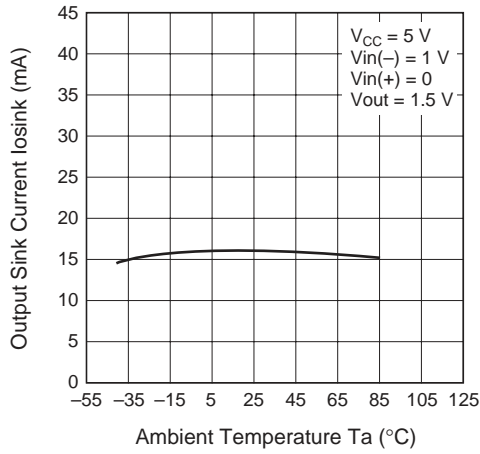

Output Sink Current vs. Power-Supply Voltage Characteristics

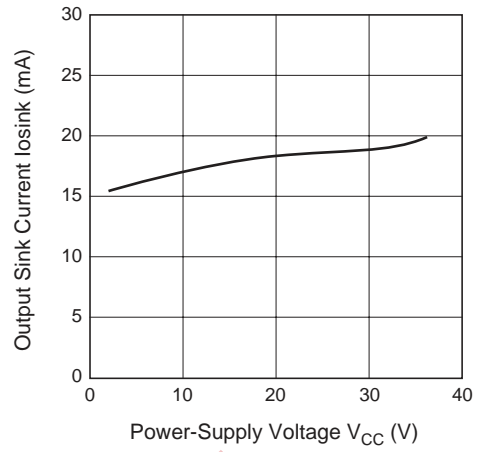

Voltage Gain vs. Ambient Temperature Characteristics

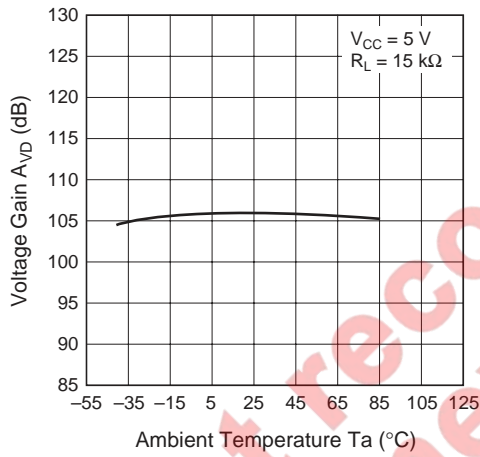

Voltage Gain vs. Power-Supply Voltage Characteristics

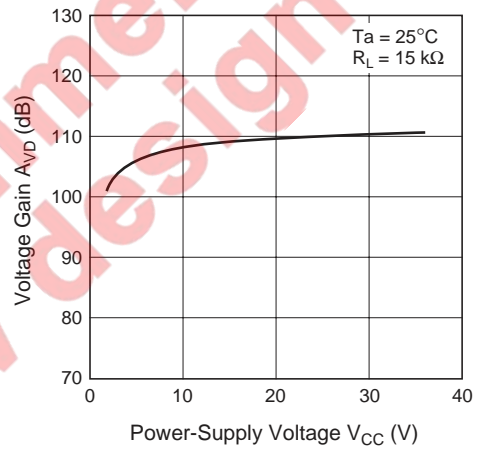

Not recommended for new design

HA17901 Application Examples

The HA17901 houses four independent comparators in a single package, and operates over a wide voltage range at low power from a single-voltage power supply. Since the common-mode input voltage range starts at the ground potential, the HA17901 is particularly suited for single-voltage power supply applications. This section presents several sample HA17901 applications.

HA17901 Application Notes

1. Square-Wave Oscillator

The circuit shown in figure one has the same structure as a single-voltage power supply astable multivibrator. Figure 2 shows the waveforms generated by this circuit.

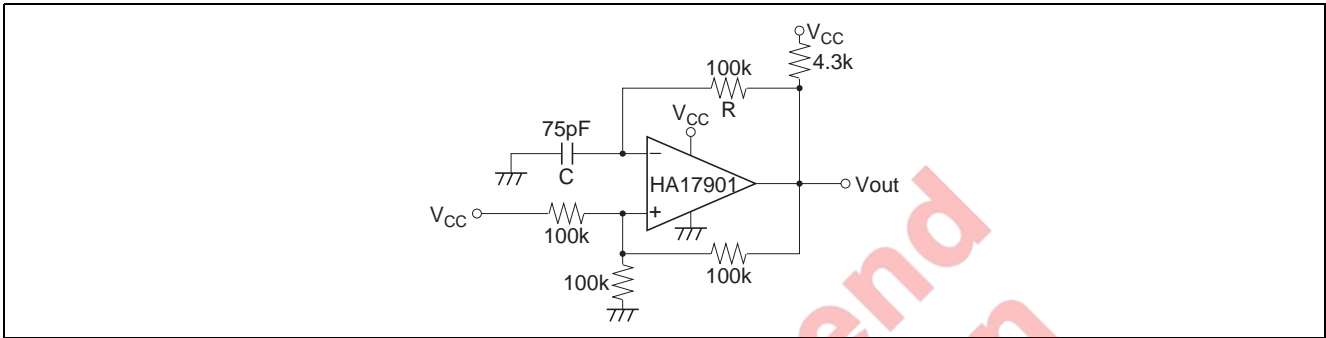

Figure 1 Square-Wave Oscillator

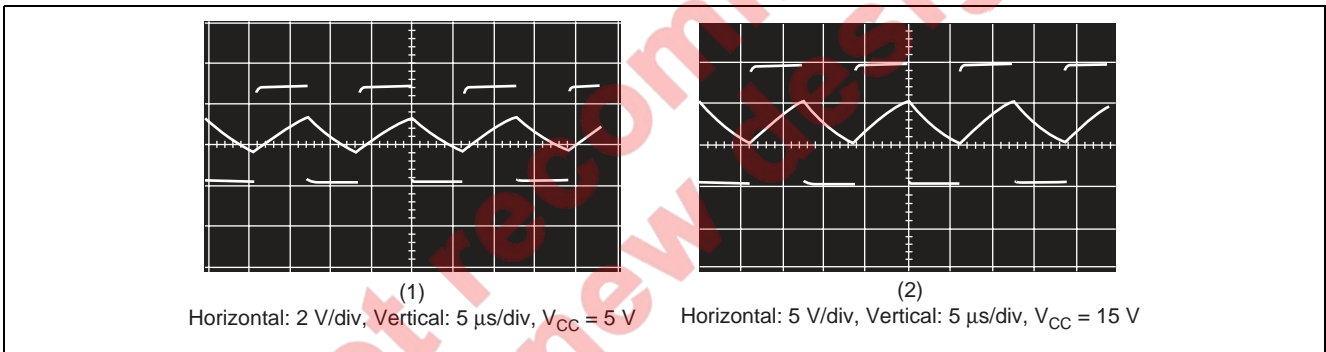

Figure 2 Operating Waveforms

2. Pulse Generator

The charge and discharge circuits in the circuit from figure 1 are separated by diodes in this circuit. (See figure 3.) This allows the pulse width and the duty cycle to be set independently. Figure 4 shows the waveforms generated by this circuit.

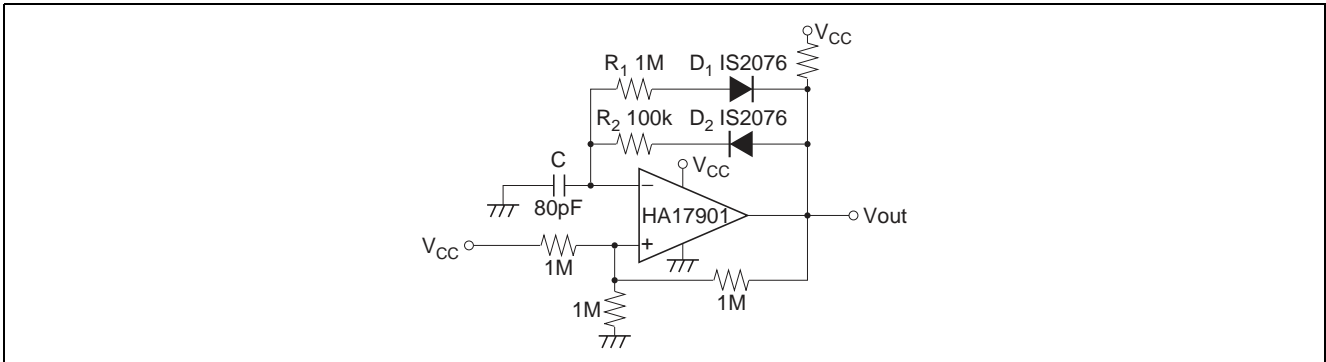

Figure 3 Pulse Generator

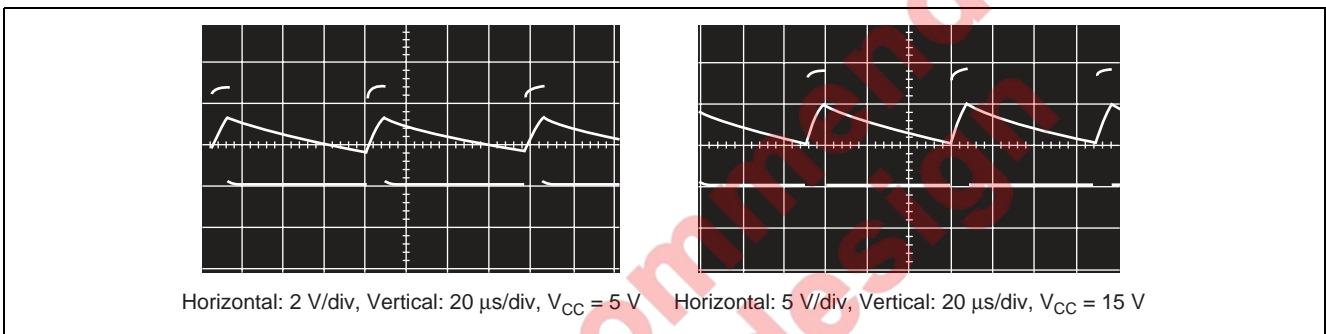

Figure 4 Operating Waveforms

3. Voltage Controlled Oscillator

In the circuit in figure 5, comparator A₁ operates as an integrator, A₂ operates as a comparator with hysteresis, and A₃ operates as the switch that controls the oscillator frequency. If the output Vout1 is at the low level, the A₃ output will go to the low level and the A₁ inverting input will become a lower level than the A₁ noninverting input. The A₁ output will integrate this state and its output will increase towards the high level. When the output of the integrator A₁ exceeds the level on the comparator A₂ inverting input, A₂ inverts to the high level and both the output Vout1 and the A₃ output go to the high level. This causes the integrator to integrate a negative state, resulting in its output decreasing towards the low level. Then, when the A₁ output level becomes lower than the level on the A₂ noninverting input, the output Vout1 is once again inverted to the low level. This operation generates a square wave on Vout1 and a triangular wave on Vout2.

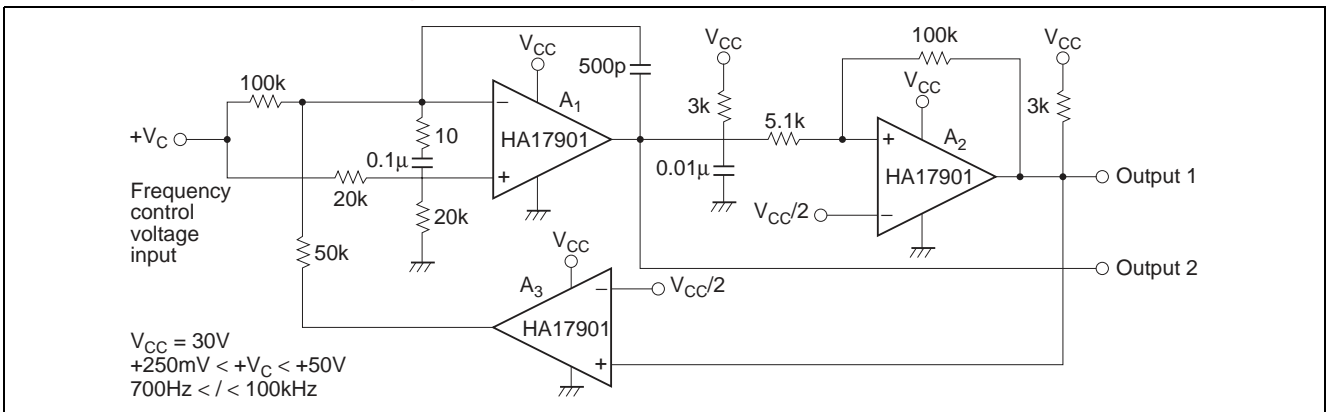

Figure 5 Voltage Controlled Oscillator

4. Basic Comparator

The circuit shown in figure 6 is a basic comparator. When the input voltage V_{IN} exceeds the reference voltage V_{REF} , the output goes to the high level.

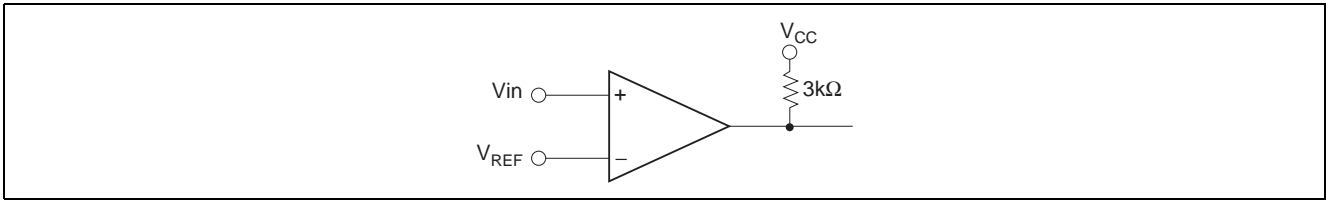

Figure 6 Basic Comparator

5. Noninverting Comparator (with Hysteresis)

Assuming $+V_{IN}$ is 0V, when V_{REF} is applied to the inverting input, the output will go to the low level (approximately 0V). If the voltage applied to $+V_{IN}$ is gradually increased, the output will go high when the value of the noninverting input, $+V_{IN} \times R_2 / (R_1 + R_2)$, exceeds $+V_{REF}$. Next, if $+V_{IN}$ is gradually lowered, V_{out} will be inverted to the low level once again when the value of the noninverting input, $(V_{out} - V_{IN}) \times R_1 / (R_1 + R_2)$, becomes lower than V_{REF} . With the circuit constants shown in figure 7, assuming $V_{CC} = 15V$ and $+V_{REF} = 6V$, the following formula can be derived, i.e. $+V_{IN} \times 10M / (5.1M + 10M) > 6V$, and V_{out} will invert from low to high when $+V_{IN}$ is $> 9.06V$.

$$(V_{out} - V_{IN}) \times \frac{R_1}{R_1 + R_2} + V_{IN} < 6V$$

(Assuming $V_{out} = 15V$)

When $+V_{IN}$ is lowered, the output will invert from high to low when $+V_{IN} < 1.41V$. Therefore this circuit has a hysteresis of 7.65V. Figure 8 shows the input characteristics.

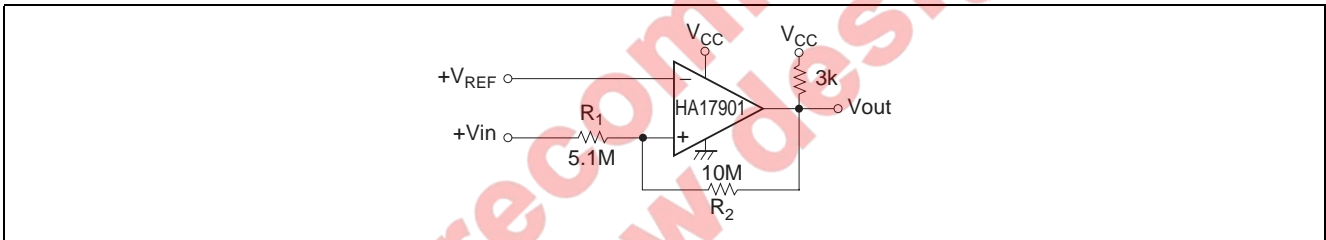

Figure 7 Noninverting Comparator

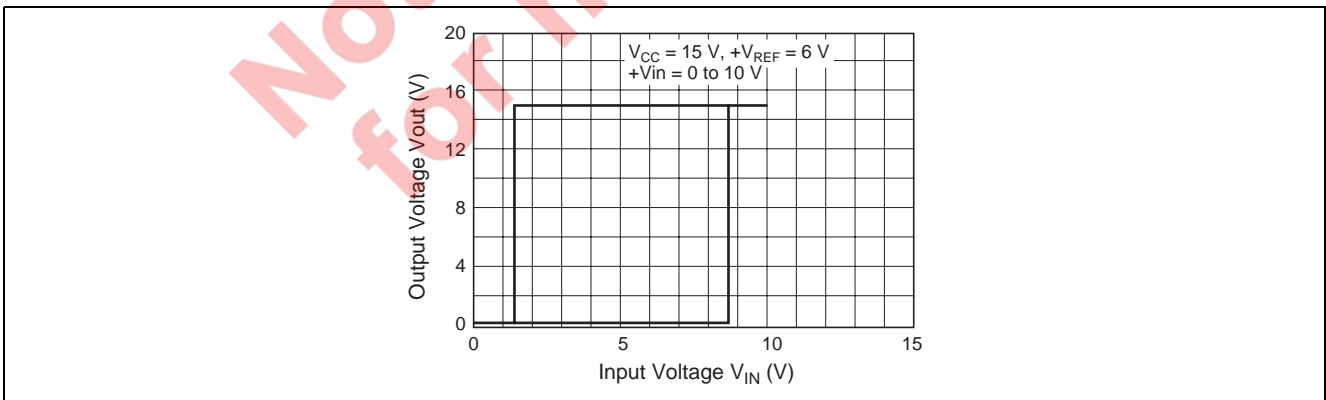

Figure 8 Noninverting Comparator I/O Transfer Characteristics

6. Inverting Comparator (with Hysteresis)

In this circuit, the output V_{out} inverts from high to low when $+V_{IN} > (V_{CC} + V_{out})/3$. Similarly, the output V_{out} inverts from low to high when $+V_{IN} < V_{CC}/3$. With the circuit constants shown in figure 9, assuming $V_{CC} = 15V$ and $V_{out} = 15V$, this circuit will have a 5V hysteresis. Figure 10 shows the I/O characteristics for the circuit in figure 9.

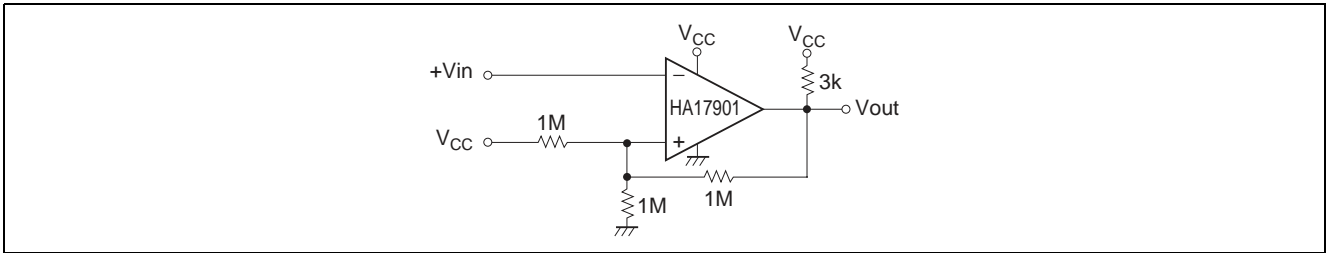

Figure 9 Inverting Comparator

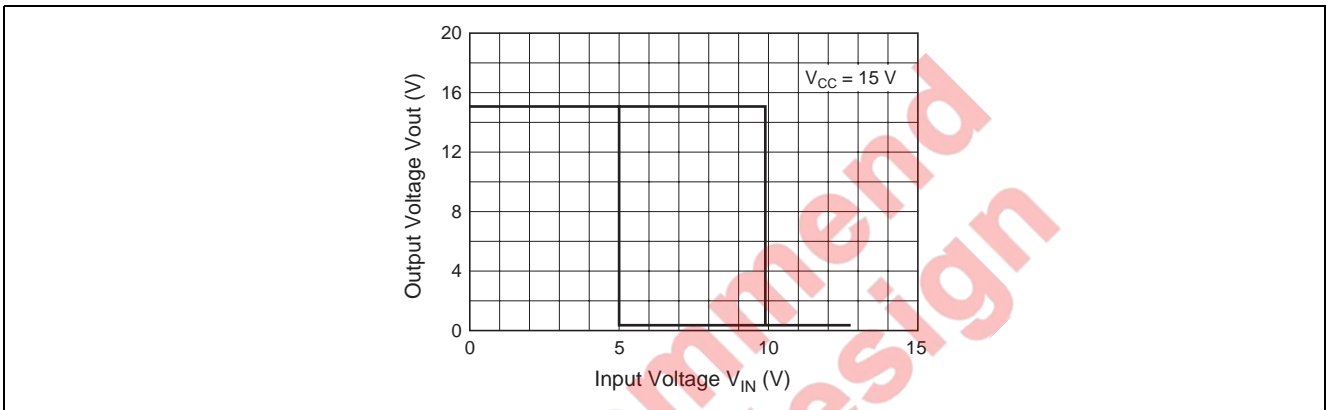

Figure 10 Inverting Comparator I/O Transfer Characteristics

7. Zero-Cross Detector (Single-Voltage Power Supply)

In this circuit, the noninverting input will essentially be held at the potential determined by dividing V_{CC} with $100k\Omega$ and $10k\Omega$ resistors. When V_{IN} is 0V or higher, the output will be low, and when V_{IN} is negative, V_{out} will invert to the high level. (See figure 11.)

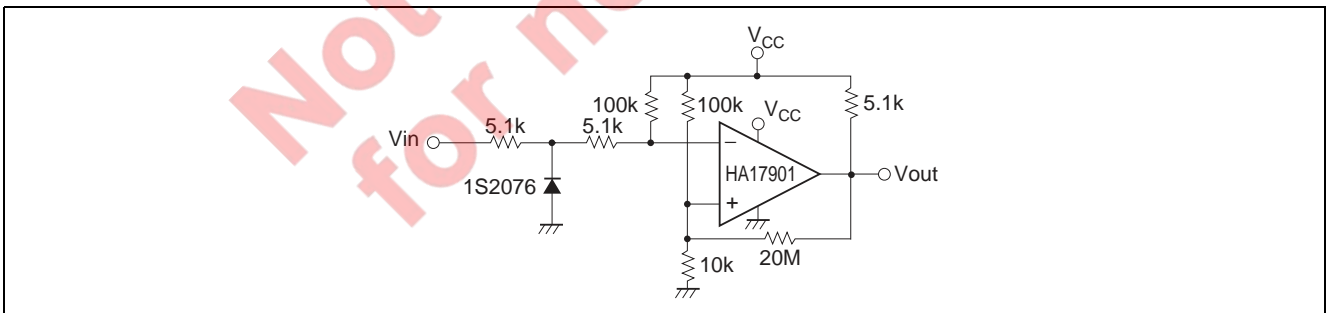
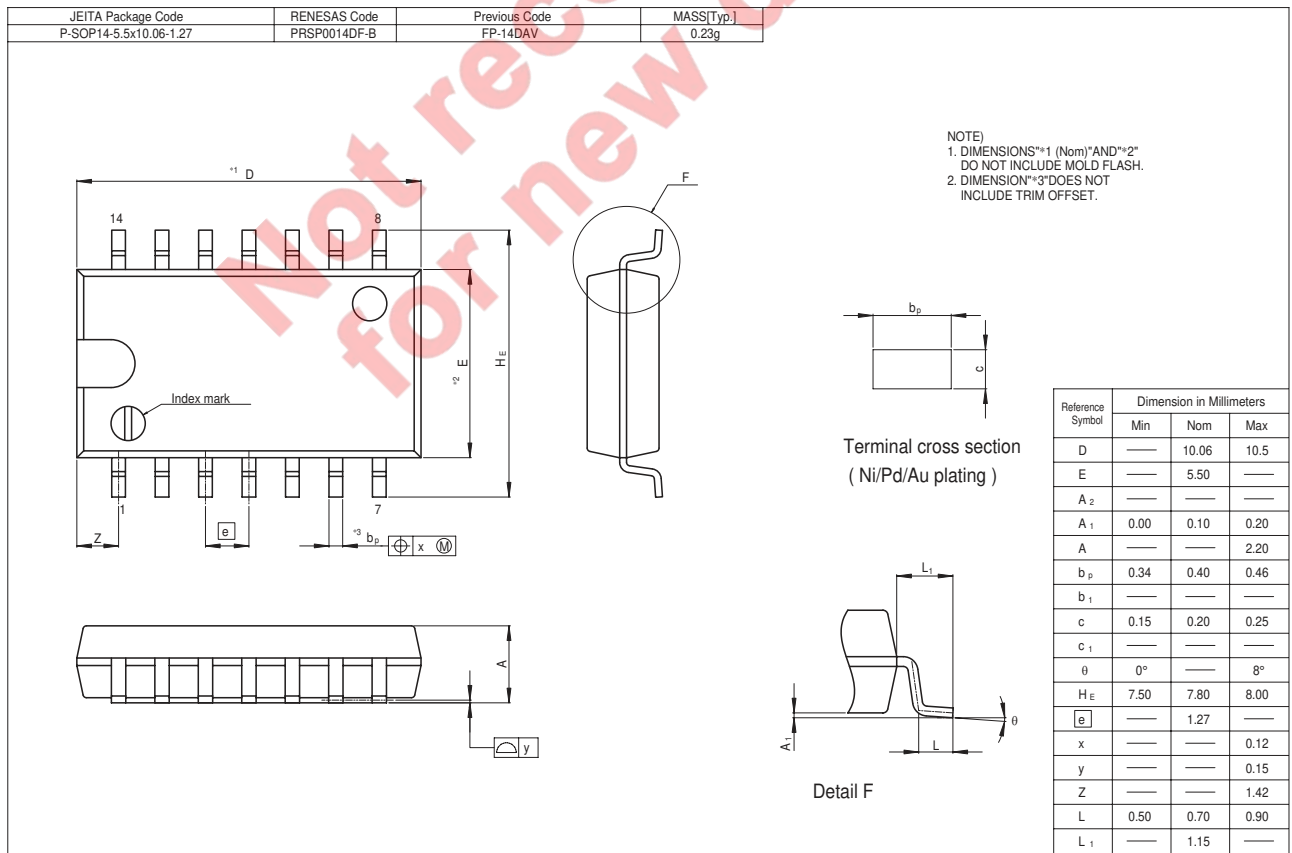
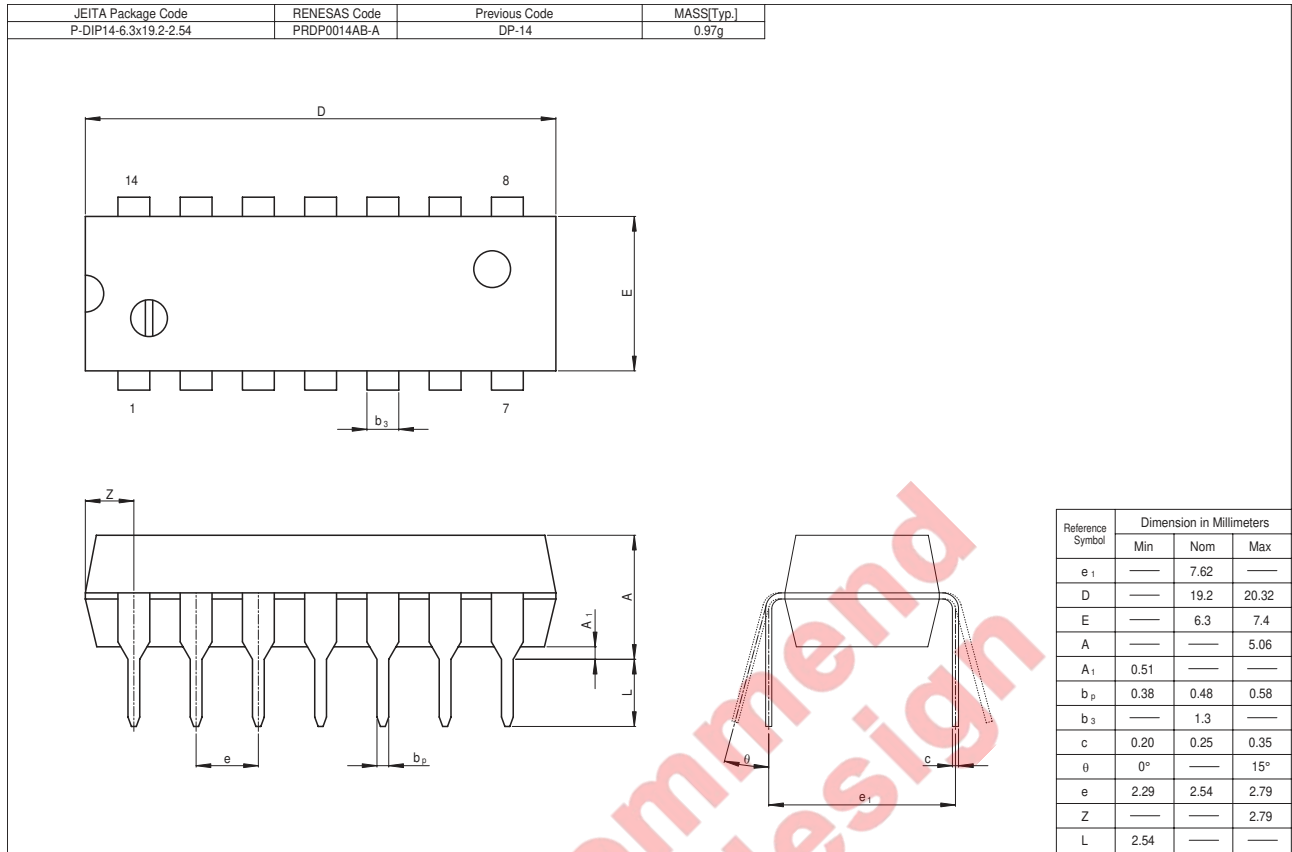

Figure 11 Zero-Cross Detector

Package Dimensions



RENESAS Technology Corp. Sales Strategic Planning Div. Nippon Bldg., 2-6-2, Ohte-machi, Chiyoda-ku, Tokyo 100-0004, Japan

Keep safety first in your circuit designs!

1. Renesas Technology Corp. puts the maximum effort into making semiconductor products better and more reliable, but there is always the possibility that trouble may occur with them. Trouble with semiconductors may lead to personal injury, fire or property damage.
Remember to give due consideration to safety when making your circuit designs, with appropriate measures such as (i) placement of substitutive, auxiliary circuits, (ii) use of nonflammable material or (iii) prevention against any malfunction or mishap.

Notes regarding these materials

1. These materials are intended as a reference to assist our customers in the selection of the Renesas Technology Corp. product best suited to the customer's application; they do not convey any license under any intellectual property rights, or any other rights, belonging to Renesas Technology Corp. or a third party.
2. Renesas Technology Corp. assumes no responsibility for any damage, or infringement of any third-party's rights, originating in the use of any product data, diagrams, charts, programs, algorithms, or circuit application examples contained in these materials.
3. All information contained in these materials, including product data, diagrams, charts, programs and algorithms represents information on products at the time of publication of these materials, and are subject to change by Renesas Technology Corp. without notice due to product improvements or other reasons. It is therefore recommended that customers contact Renesas Technology Corp. or an authorized Renesas Technology Corp. product distributor for the latest product information before purchasing a product listed herein.
The information described here may contain technical inaccuracies or typographical errors.
Renesas Technology Corp. assumes no responsibility for any damage, liability, or other loss rising from these inaccuracies or errors.
Please also pay attention to information published by Renesas Technology Corp. by various means, including the Renesas Technology Corp. Semiconductor home page (<http://www.renesas.com>).
4. When using any or all of the information contained in these materials, including product data, diagrams, charts, programs, and algorithms, please be sure to evaluate all information as a total system before making a final decision on the applicability of the information and products. Renesas Technology Corp. assumes no responsibility for any damage, liability or other loss resulting from the information contained herein.
5. Renesas Technology Corp. semiconductors are not designed or manufactured for use in a device or system that is used under circumstances in which human life is potentially at stake. Please contact Renesas Technology Corp. or an authorized Renesas Technology Corp. product distributor when considering the use of a product contained herein for any specific purposes, such as apparatus or systems for transportation, vehicular, medical, aerospace, nuclear, or undersea repeater use.
6. The prior written approval of Renesas Technology Corp. is necessary to reprint or reproduce in whole or in part these materials.
7. If these products or technologies are subject to the Japanese export control restrictions, they must be exported under a license from the Japanese government and cannot be imported into a country other than the approved destination.
Any diversion or reexport contrary to the export control laws and regulations of Japan and/or the country of destination is prohibited.
8. Please contact Renesas Technology Corp. for further details on these materials or the products contained therein.

RENESAS SALES OFFICES



<http://www.renesas.com>

Refer to "<http://www.renesas.com/en/network>" for the latest and detailed information.

Renesas Technology America, Inc.
450 Holger Way, San Jose, CA 95134-1368, U.S.A
Tel: <1> (408) 382-7500, Fax: <1> (408) 382-7501

Renesas Technology Europe Limited
Dukes Meadow, Millboard Road, Bourne End, Buckinghamshire, SL8 5FH, U.K.
Tel: <44> (1628) 585-100, Fax: <44> (1628) 585-900

Renesas Technology Hong Kong Ltd.
7th Floor, North Tower, World Finance Centre, Harbour City, 1 Canton Road, Tsimshatsui, Kowloon, Hong Kong
Tel: <852> 2265-6688, Fax: <852> 2730-6071

Renesas Technology Taiwan Co., Ltd.
10th Floor, No.99, Fushing North Road, Taipei, Taiwan
Tel: <886> (2) 2715-2888, Fax: <886> (2) 2713-2999

Renesas Technology (Shanghai) Co., Ltd.
Unit2607 Ruijing Building, No.205 Maoming Road (S), Shanghai 200020, China
Tel: <86> (21) 6472-1001, Fax: <86> (21) 6415-2952

Renesas Technology Singapore Pte. Ltd.
1 Harbour Front Avenue, #06-10, Keppel Bay Tower, Singapore 098632
Tel: <65> 6213-0200, Fax: <65> 6278-8001