

9400 Series Tri-Mode Storage HBAs

12Gb/s SAS/SATA/NVMe Tri-Mode PCIe HBAs

Industry's First HBA with Tri-Mode SerDes Technology

Broadcom enables high performance storage connectivity and flexible system designs that support any combination of NVMe, SAS and SATA devices with the industry's first HBA with Tri-Mode SerDes. The Tri-Mode HBAs expand Broadcom's industry leading family of 12Gb/s SAS HBAs with 8 and 16 port internal, external and combination Tri-Mode port options.

NVMe Performance Gains for Storage

The Tri-Mode Storage HBAs bring NVMe performance benefits to the storage tier by providing connectivity and data protection that HBAs have offered for over 20 years for SAS/SATA interfaces. Based on the single-core SAS3516, SAS3416, or SAS3408 Tri-Mode Storage I/O controllers (IOC), these HBAs provide bandwidth and IOPS performance increase compared to the previous generation and are ideal for high-end servers utilizing internal storage or connecting to large-scale external storage enclosures.

Endless Design Flexibility Using Tri-Mode Controllers

Broadcom Tri-Mode SerDes Technology enables the operation of NVMe, SAS, or SATA storage devices in a single drive bay. A single controller can operate in all three modes concurrently servicing NVMe, SAS, or SATA drives. The controller negotiates between the speeds and protocols to seamlessly work with any of the three types of storage devices. Tri-Mode support provides a non-disruptive way to evolve existing data center infrastructure. By upgrading to a Tri-Mode HBA, users can expand beyond SAS/SATA and use NVMe without major changes to other system configurations.



Applications

- High-port count SAS/SATA/NVMe adapters for direct attached high connectivity applications
- Tri-Mode connectivity enabling maximum data center flexibility
- Flexible solutions for cloud computing
- External storage requiring high connectivity SAS/SATA interface for host or drive side connect

Key Features

- Tri-Mode Storage Interface Ports
 - SFF-8680 Bay
 - x1 SAS
 - x1 SATA
 - x2 SAS (Multi Link)
 - Two x1 SAS (Dual port using MPIO)
 - SFF-8639 (U.2) Bay
 - x2, x4 NVMe
- Supports 12, 6, and 3Gb/s SAS and 6, 3Gb/s SATA data transfer rates
- Up to 8 storage interface PCIe links. Each link supporting x4 or x2 link widths up to 8.0 GT/s (PCIe 3.0) per lane
- SFF-9402 Compliant, Connector Pin-out

Key Features (cont.)

- SFF-8485 Compliant, SGPIO
- PCIe 3.1 Host Interface
 - Supports x8, x4, x2, x1 PCIe lanes at a transfer rate up to 8.0 GT/s per lane, full duplex
 - Lane and polarity reversal
 - Variable PCIe bandwidth negotiation

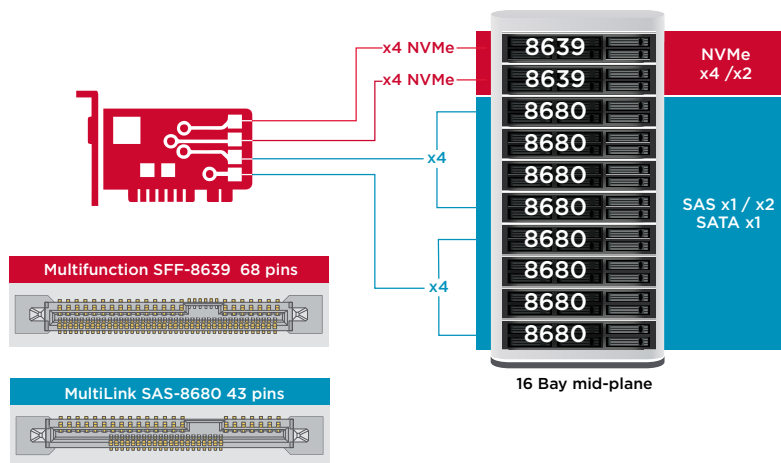

9400 Series Tri-Mode Storage HBAs

	9400-16i	9400-8i	9400-16e	9400-8e	9400-8i8e
Ports	16 internal	8 internal	16 external	8 external	8 internal/8 external
Connectors	Four (x4) SFF-8643	Two (x4) SFF-8643	Four (x4) SFF-8644	Two (x4) SFF-8644	Two (x4) SFF-8643; Two (x4) SFF-8644
Storage Interface Support	SAS, SATA, NVMe (PCIe)				
Max NVMe Direct Attach Devices	4 x4, 8 x2	2 x4, 4 x2	N/A	N/A	2 x4, 4 x2 (internal only)
Max Devices Per Controller	SAS/SATA: 1024 NVMe: 24	SAS/SATA: 1024 NVMe: 24	SAS/SATA: 1024	SAS/SATA: 1024	SAS/SATA: 1024 NVMe: 24 (internal only)
I/O Processor/SAS Controller	SAS3416	SAS3408	SAS3416	SAS3408	SAS3516
Host Bus Type	PCIe 3.1 x8				
Typical Power	11.95W	10.05W	11.18W	9.48W	12.39W
Physical Dimensions	6.127 in. x 2.712 in. (155.65 mm x 68.90 mm)	6.127 in. x 2.712 in. (155.65 mm x 68.90 mm)	6.600 in. x 2.712 in. (167.65 mm x 68.90 mm)	6.600 in. x 2.712 in. (167.65 mm x 68.90 mm)	6.600 in. x 2.712 in. (167.65 mm x 68.90 mm)
Cable Support	Passive Copper	Passive Copper	Passive Copper, Active Copper, Active Optical	Passive Copper, Active Copper, Active Optical	Passive Copper, Active Copper (external), Active Optical (external)
Operating Conditions	Operating: 0°C to 55°C, 20 to 80% non-condensing, Airflow: 200 LFM, Storage: -45°C to +105°C, 5 to 95% non-condensing				
MTBF (Calculated)	>4,500,000 hours at 40°C				
Operating Voltage	+12V ±8%; 3.3V ±9%				
Hardware Warranty	3 years; with advanced replacement option				
Management Software	LSA (LSI Storage Authority), StorCLI (Command-Line Interface), HII (UEFI Human Interface Infrastructure)				
Regulatory Certifications	USA (FCC 47 CFR part 15 Subpart B, class B); Canada (ICES -003, Class B); Taiwan (CNS 13438); Japan (VCCI V-3); Australia/New Zealand (AS/NZS CISPR 22); Korea (RRA no 2013-24 & 25); Europe (EN55022/EN55024); Safety: EN/IEC/UL 60950; RoHS; WEEE				
OS Support	Microsoft Windows, VMware vSphere/ESXi, Red Hat Enterprise Linux, SuSE Linux, Ubuntu Linux, Citrix XenServer, CentOS Linux, Debian Linux, Oracle Enterprise Linux, Fedora, and FreeBSD. See www.broadcom.com/support/download-search for details on versions.				
Ordering Information					
Single Pack	05-50008-00	05-50008-01	05-50013-00	05-50013-01	05-50031-02