

used for: D-SUB

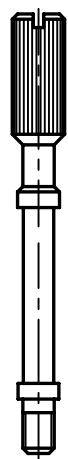

2 x JACK SCREW

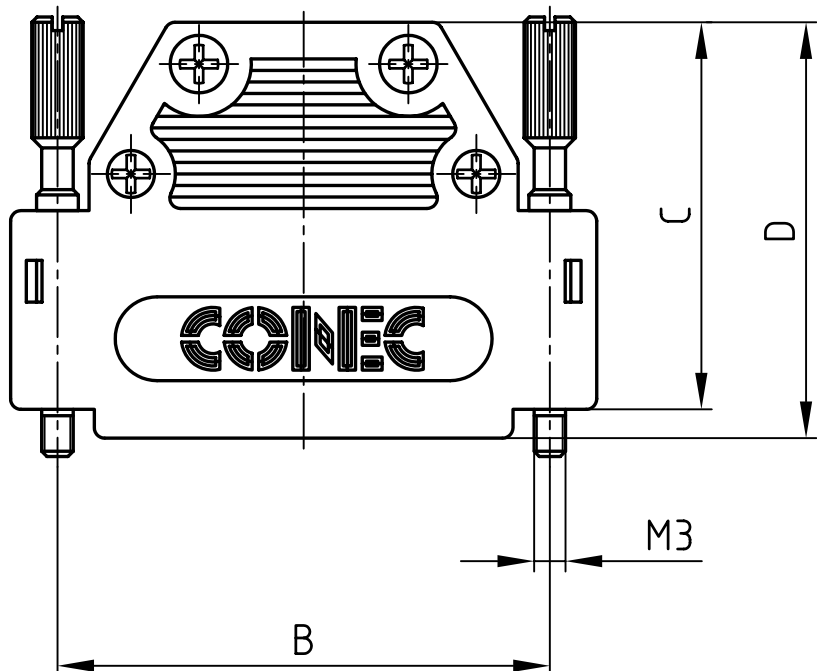
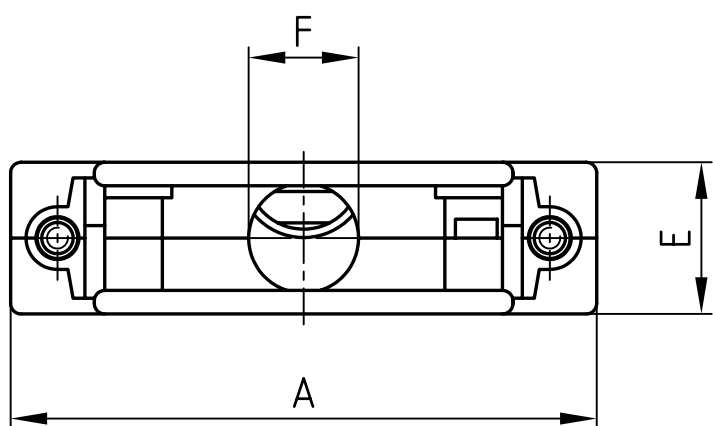

2 x KNURLED NUT

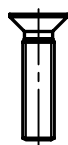

2 x COUNTERSUNK-HEAD SCREW



2 x PAN-HEAD SCREW

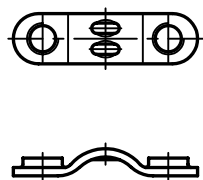

1 x CABLE STRAIN RELIEF

No. of pos.	A	B	C	D	E	F	Part No. Bulk package	Part No. Single package
15	42.3	33.3	37.0	39.75	14.5	10.0	165X10969X	165X10969XE
37	72.5	63.5	37.0	39.75	14.5	10.5	165X10989X	165X10989XE
50	67.0	61.1	49.1	51.40	19.8	14.0	165X10999X	165X10999XE

Directive 2002/95/EC
„RoHS“
Compliant

APPROVAL # FREIGABE # DEBLOCAGE # AUTORIZACION # APPROVAL

CUSTOMER APPROVAL DATE:

NAME: TITLE:

COMPANY NAME:

APPROVAL # FREIGABE # DEBLOCAGE # AUTORIZACION # APPROVAL

HOOD ASSEMBLY CONSISTS OF:

1. HOOD: ABS UL 94 V-0; METALLIZED
2. JACK SCREW: BRASS; NICKEL PLATED
3. KNURLED NUT: BRASS; NICKEL PLATED
4. COUNTERSUNK-HEAD SCREW: STEEL; NICKEL PLATED
5. PAN-HEAD SCREW: STEEL; NICKEL PLATED
6. CABLE STRAIN RELIEF: STEEL; NICKEL PLATED

THIS DRAWING MAY NOT BE COPIED OR REPRODUCED IN ANY WAY, AND MAY NOT BE PASSED ON TO A THIRD PARTY WITHOUT WRITTEN PERMISSION.
OWNERSHIP AND COPYRIGHT OF CONEC GmbH
DO NOT ALTER CAD DRAWING BY HAND

tolerance		dim. in mm	
2009	date	name	
drawn	17.02.	Lehmenkühler	
appd.	17.02.	Fischer	
norm			
d-old			
a	Origin		
rev.	description	date	name



scale:	1:1
material:	SEE NOTES
title:	PLASTIC HOOD 15pos. / 37pos. / 50pos. with straight cable exit and jack screws
dwg no:	AutoCAD 2006 16K1A2452
part no:	SEE TABLE

4

3

2

1