

(b) Technical specification:

Technische Daten:

Working voltage/ Betriebsspannung:	125 V AC
Insulation resistance/ Isolationswiderstand:	≥ 5 GΩ
Dielectric withstanding voltage/ Spannungsfestigkeit:	1000 V, 50 Hz, 1 min.
Temperature range/ Temperaturbereich:	-55 °C ... +125 °C
Current rating/ Strombelastbarkeit:	7,5 A (UL) / 5 A (CSA, VDE)
Mating cycles/ Steckzyklen:	Quality class 1 = 500 Gütestufe 1 Quality class 2 = 200 Gütestufe 2 Quality class 3 = 50 Gütestufe 3

**Materials/
Werkstoffe:**

Contact/ Kontakt:	Cu alloy, Au over Ni
Insulator/ Isolierkörper:	PBT GF UL 94 V-0
Shell/ Gehäuse:	Steel, Sn over Ni
Metal bracket/ Metallwinkel:	Steel, Sn
Threaded lock/ Gewindebolzen:	Cu alloy, Sn over Ni
Fixing plate/ Zentrierplatte:	PBT GF UL 94 V-0
PCB snap/ PCB Clip:	Cu alloy, Sn over Ni

**Installation specification/
Montagedaten:**

Recommended torque value for thread/ Empfohlenes Drehmoment für Gewinde:	max. 6 in.LB/ max. 67 Ncm
PCB hole drillings/ Leiterplattenbohrbild:	see sheet 2/ siehe Seite 2
PCB thickness/ Leiterplatten Dicke:	1,6 mm
PCB snap for hole diameter/ PCB Clip für Lochdurchmesser:	Ø3,1 mm

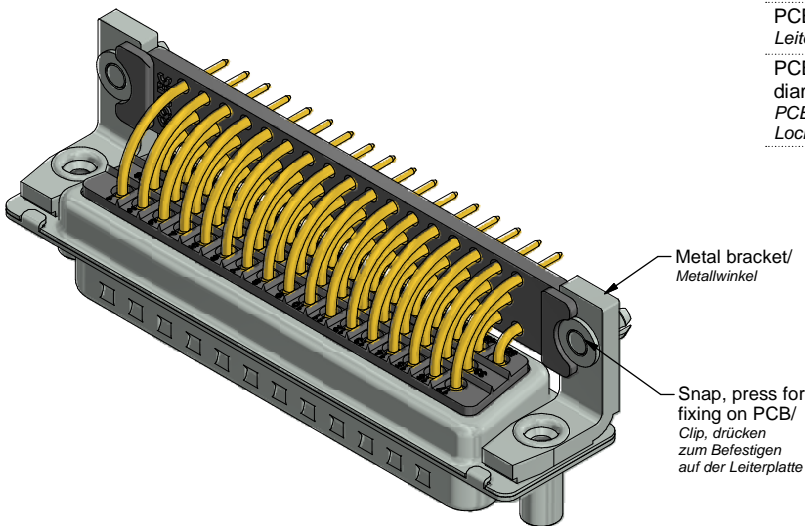
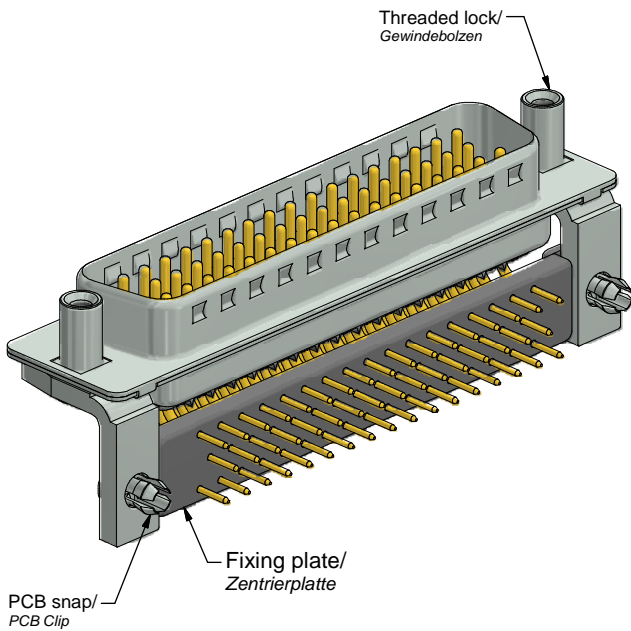

(b)

Part no. / Part marked/ Art.-Nr. / Bedruckung:	Quality class/ Gütestufe:	Contact plating/ Kontakt Veredelung:
163A18649X	3	Gold flash over nickel Gold über Nickel
163B18649X	2	20 µin hard gold over min. 50 µin nickel 20 µin Gold über min. 50 µin Nickel
163C18649X	1	30 µin hard gold over min. 50 µin nickel 30 µin Gold über min. 50 µin Nickel

		D-SUB Male 90° 50pos. 0.318 inch with threaded lock, metal bracket, fixing plate, snap D-SUB Stiftleiste 90° 50pol. 7,19 mm mit Gewindebolzen, Metallwinkel, Zentrierplatte, Clip	
Index: b Ä6892 28.09.17 HS	Scale/Maßstab: 2:1	Date/Datum: 27.05.03 Name: Lehmenkühler appd./gepr.: 27.05.03 Kühle	dwg no / Z.-nr.: 16K1A963
Status: InBearbeitung		DIN-A3 1 / 2	
RoHS compliant/konform			

The reproduction, distribution and utilization of this document as well as the communication of its contents to others without express authorization is prohibited. Offenders will be held liable for the payment of damages. Wir bitten Sie, die Weitergabe, Verbreitung und Nutzung dieses Dokuments sowie die Kommunikation seiner Inhalte an Dritte ohne unsere ausdrückliche Genehmigung zu vermeiden. Zuwiderhandlungen werden strafrechtlich verfolgt.

PCB hole drillings
(PCB top side) /
Leiterplattenbohrbild
(Leiterplatten Oberseite)

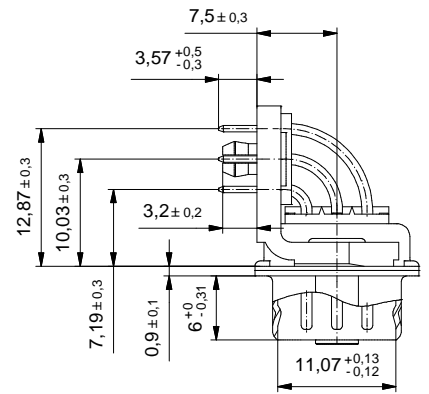
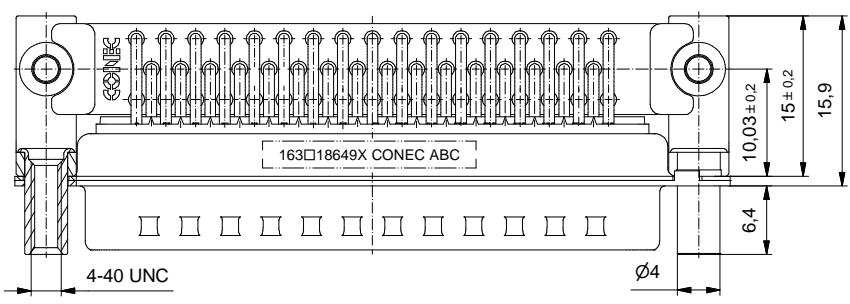
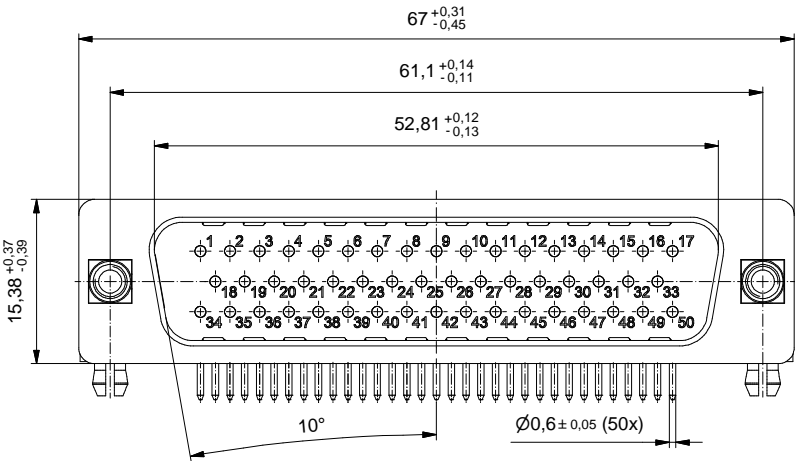
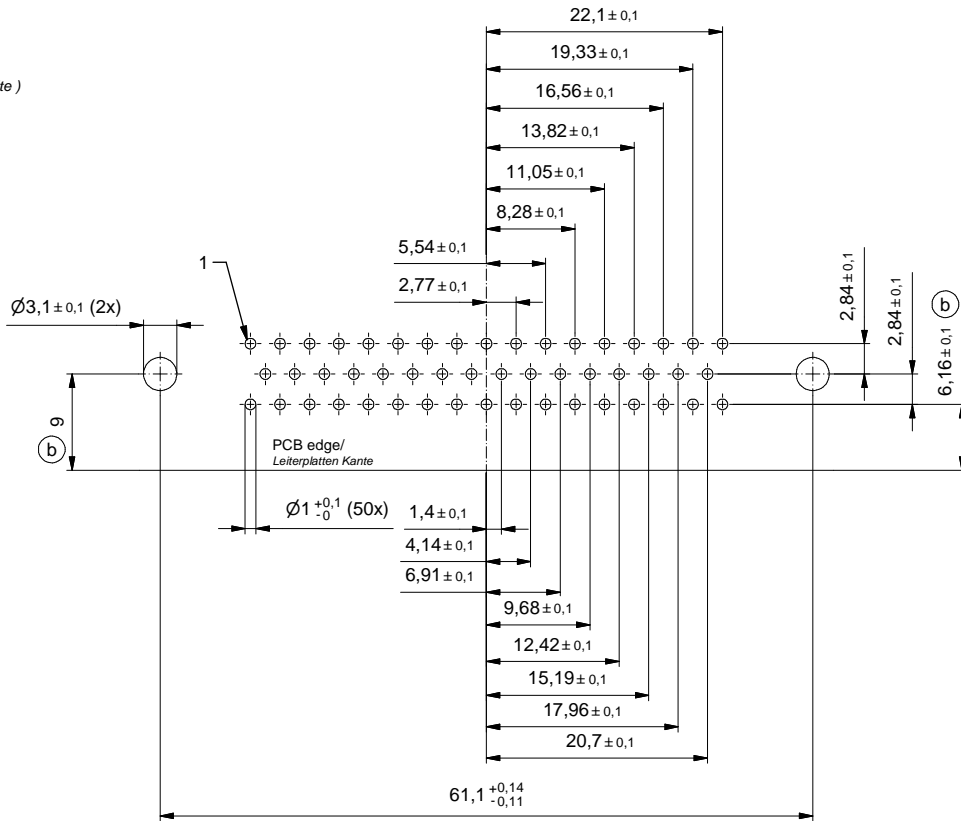

Index: b Ä6892 28.09.17 HS		Scale/Maßstab: 2:1				D-SUB Male 90° 50pos. 0.318 inch with threaded lock, metal bracket, fixing snap D-SUB Stiftleiste 90° 50pol. 7,19 mm mit Gewindebolzen, Metallwinkel, Zentrierplatte, Clip		dwg no / Z.-nr.: 16K1A963		DIN- A3	
Status: InBearbeitung		RoHS compliant/konform		Date/Datum: 27.05.03 Name: Lehmenkühler drawn/gez.: 27.05.03 appd./gepr.: 27.05.03 Name: Kühle		2 / 2					

The reproduction, distribution and utilization of this document as well as the communication of its contents to third parties without express authorization is prohibited. Offenders will be held liable for the payment of damages. For further information on this subject, please contact your nearest CONEC branch office.