

DETAIL B  
SCALE 20:1

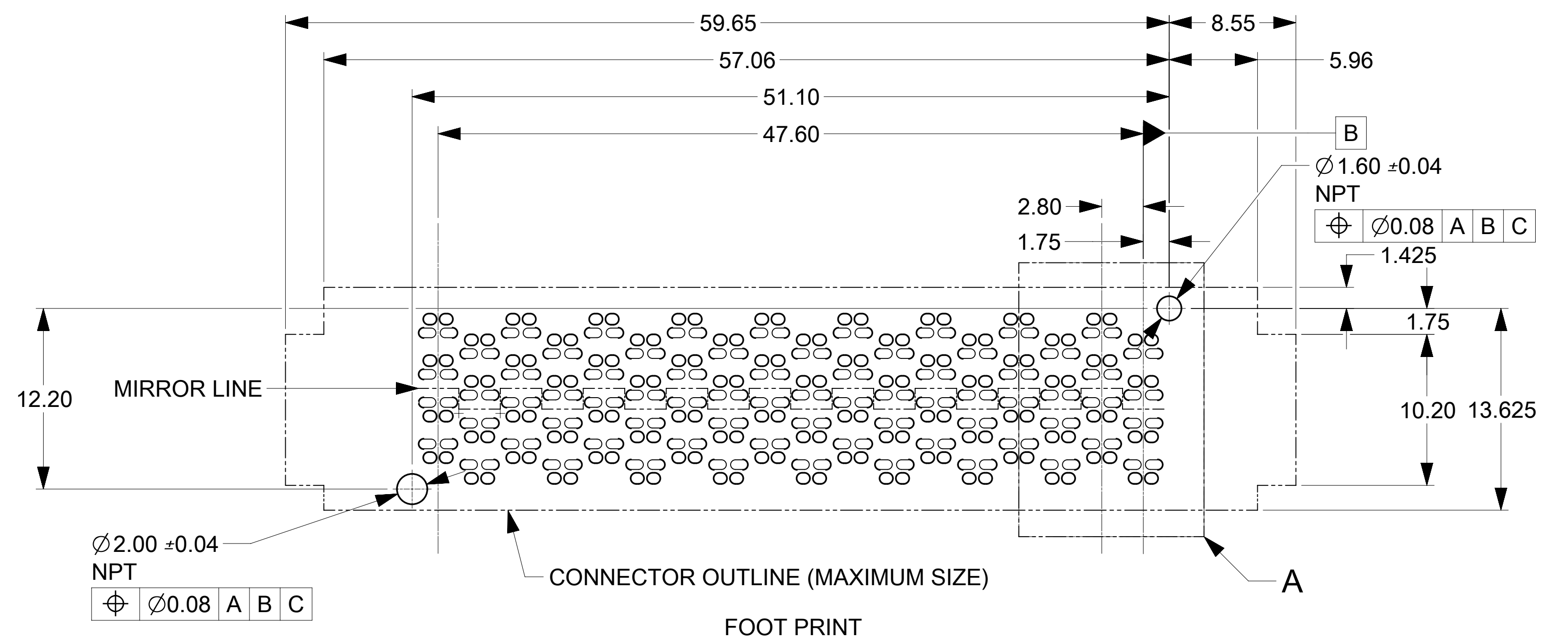

FOOT PRINT NOTES:  
 1. DATUM -A- IS THE TOP OF THE PCB.  
 2. ALL DIMENSIONS ARE BASICS.  
 3. SEE APPLICATION SPECIFICATION FOR ADDITIONAL INFORMATION.

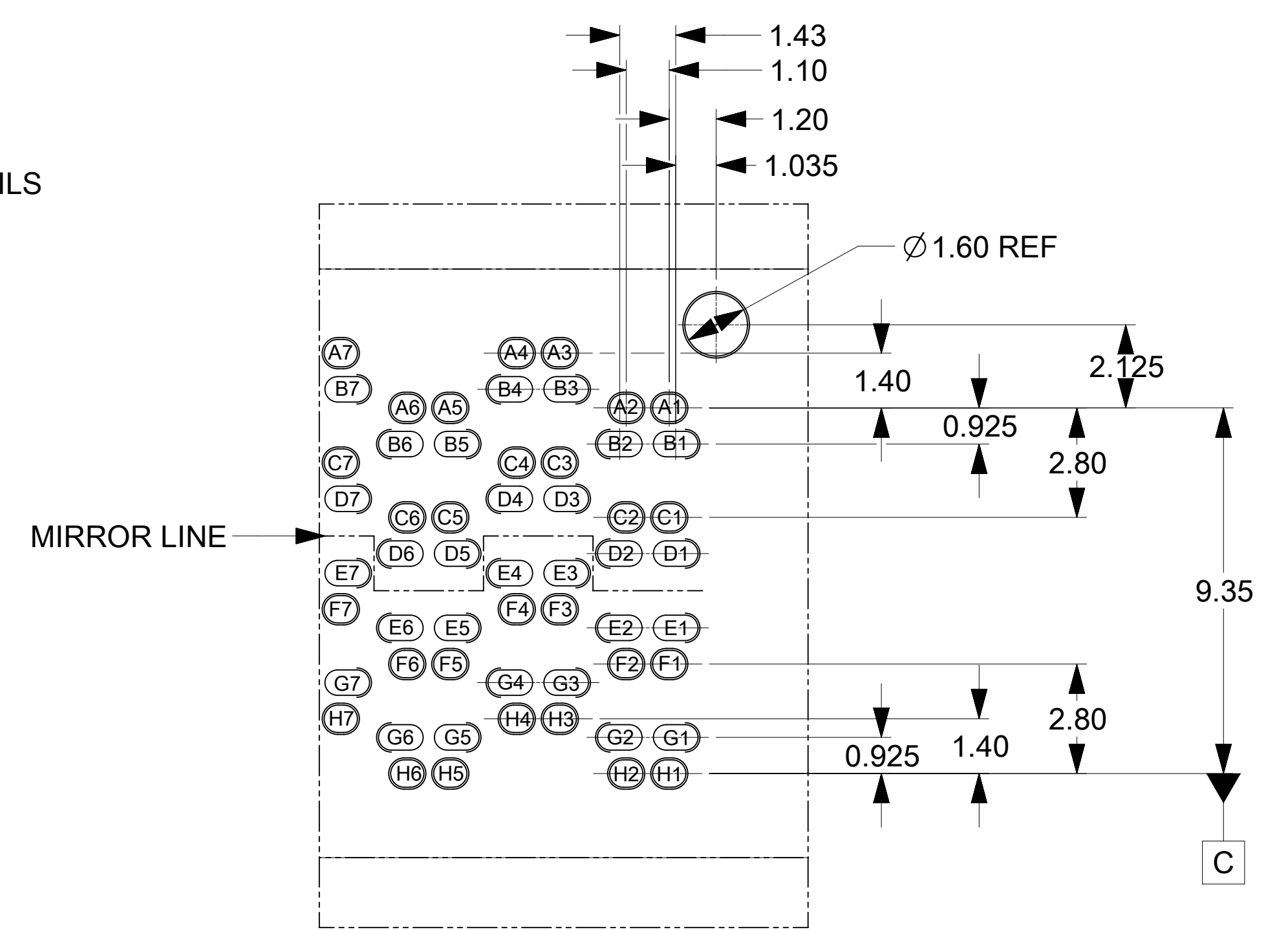
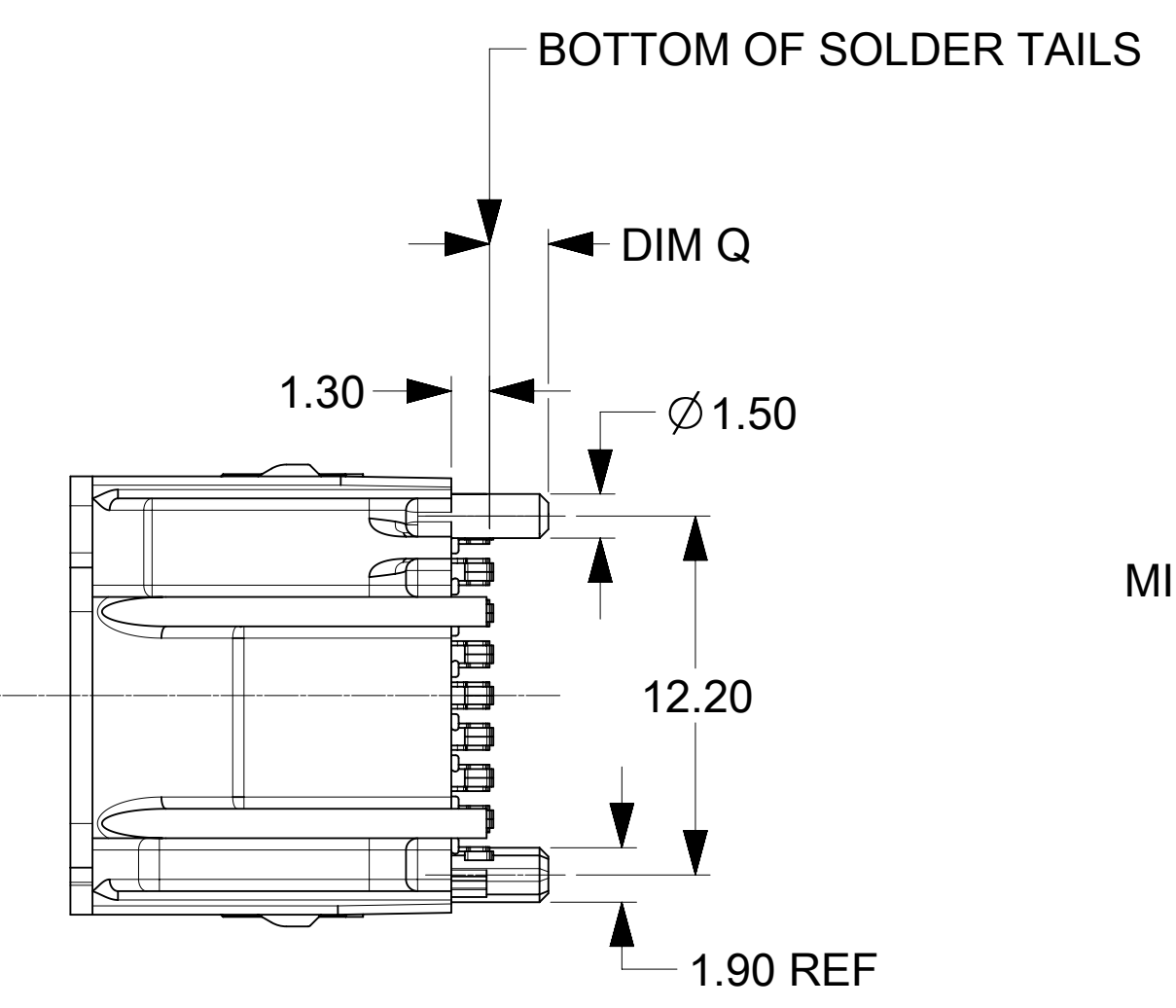

DETAIL A  
SCALE 8:1  
(NUMBERING SCHEME SHOWN)

- NOTES:
- HOUSING MATERIAL: LCP, GLASS FILLED, UL 94V-0, BLACK  
 CONTACT MATERIAL: HIGH PERFORMANCE COPPER ALLOY  
 SOLDER CHARGE: LEAD FREE SOLDER ALLOY
  - FINISH:  
 CONTACTS: SELECT GOLD: 30 μINCHES MIN ON CONTACT AREA,  
 AND 100 μINCHES TIN MIN ON SOLDERABLE PORTION  
 OF SOLDER TAILS; OVER 50 μINCHES MIN NICKEL OVERALL.
  - PRODUCT SPECIFICATION: PS-170807-0001
  - PACKAGING SPECIFICATION: PK-170807-0002
  - APPLICATION SPECIFICATION: AS-170807-0001

SYMBOLS		THIS DRAWING CONTAINS INFORMATION THAT IS PROPRIETARY TO MOLEX ELECTRONIC TECHNOLOGIES, LLC AND SHOULD NOT BE USED WITHOUT WRITTEN PERMISSION	
▽ = 0	mm	SCALE	NTS
▽ = 0	GENERAL TOLERANCES (UNLESS SPECIFIED)		
▽ = 0	ANGULAR TOL	±	0.5°
▽ = 0	4 PLACES	±	
▽ = 0	3 PLACES	±	
▽ = 0	2 PLACES	±	0.15
▽ = 0	1 PLACE	±	
▽ = 0	0 PLACES	±	
■ = 0	DRAFT WHERE APPLICABLE MUST REMAIN WITHIN DIMENSIONS		
▽ = 0	THIRD ANGLE PROJECTION	DRAWING	SERIES
		D-SIZE	170807
CURRENT REV DESC: SAME AS REV A2		EC NO: 614258	
		DRWN: HCGOH	2019/03/21
		CHK'D: CLHOE01	2019/03/22
		APPR: SHONG	2019/03/25
		INITIAL REVISION:	
		DRWN: KPELOZA	2014/02/28
		APPR: SHONG	2014/06/02
DOCUMENT NUMBER		DOC TYPE	DOC PART
SD-170807-0036		PSD	001
MATERIAL NUMBER		CUSTOMER	SHEET NUMBER
SEE TABLE		GENERAL MARKET	1 OF 4

**molex**

PLUG  
4X18 NEOSCALE, BLIND MATE

PRODUCT CUSTOMER DRAWING

DOCUMENT NUMBER: SD-170807-0036, DOC TYPE: PSD, DOC PART: 001, REVISION: A3

MATERIAL NUMBER	HEIGHT	TRIAD TYPE AND COUNT			DIM Q	MATE WITH	REMARKS
		85 OHMS	100 OHMS	POWER			
1708070036	7.00MM	40 PLACES	28 PLACES	4 PLACES	2	1708140036 (8MM)	REFER TO PAGE 3 FOR PIN OUT CHART
1708070048	7.00MM	40 PLACES	28 PLACES	4 PLACES	1.27		
1708070039	7.00MM	72 PLACES	N/A	N/A	2	1708140039 (8MM)	N/A
1708072025	7.00MM	N/A	72 PLACES	N/A	2	1708142024 (8MM)	N/A
1708073005	7.00MM	68 PLACES	N/A	4 PLACES	2	1708143005 (10MM)	REFER TO PAGE 4 FOR PIN OUT CHART

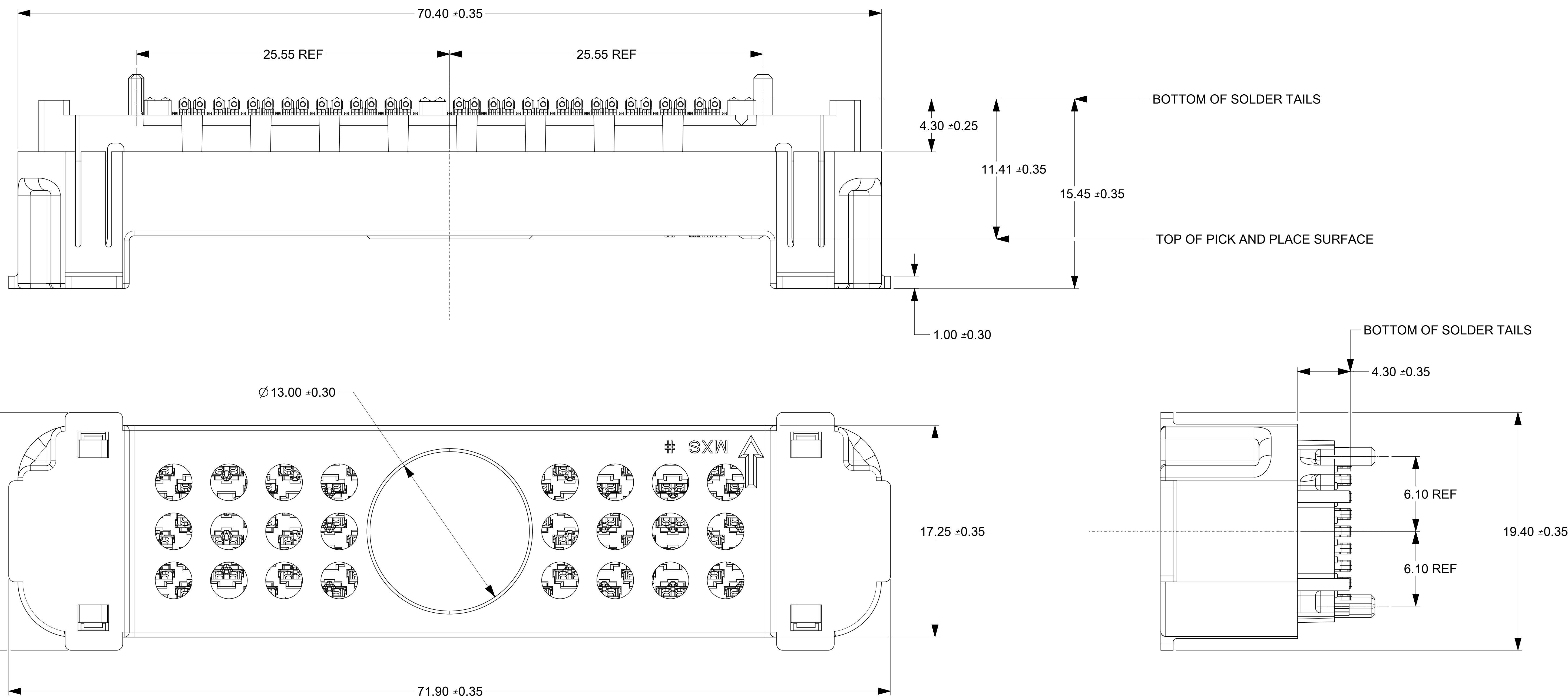

# COVER PICK AND PLACE

SYMBOLS	THIS DRAWING CONTAINS INFORMATION THAT IS PROPRIETARY TO MOLEX ELECTRONIC TECHNOLOGIES, LLC AND SHOULD NOT BE USED WITHOUT WRITTEN PERMISSION		
	DIMENSION UNITS	SCALE	CURRENT REV DESC: SAME AS REV A2
▽ = 0	mm	NTS	
▽ = 0	GENERAL TOLERANCES (UNLESS SPECIFIED)		
▽ = 0	ANGULAR TOL	± 0.5°	
▽ = 0	4 PLACES	±	EC NO: 614258
▽ = 0	3 PLACES	±	DRWN: HCGOH 2019/03/21
▽ = 0	2 PLACES	± 0.15	CHK'D: CLHOE01 2019/03/22
▽ = 0	1 PLACE	±	APPR: SHONG 2019/03/25
▽ = 0	0 PLACES	±	INITIAL REVISION:
☒ = 0	DRAFT WHERE APPLICABLE MUST REMAIN WITHIN DIMENSIONS		
☒ = 0	THIRD ANGLE PROJECTION	DRAWING	SERIES
		D-SIZE	170807
DOCUMENT NUMBER		DOC TYPE	DOC PART
SD-170807-0036		PSD	001
MATERIAL NUMBER		CUSTOMER	SHEET NUMBER
SEE TABLE		GENERAL MARKET	2 OF 4

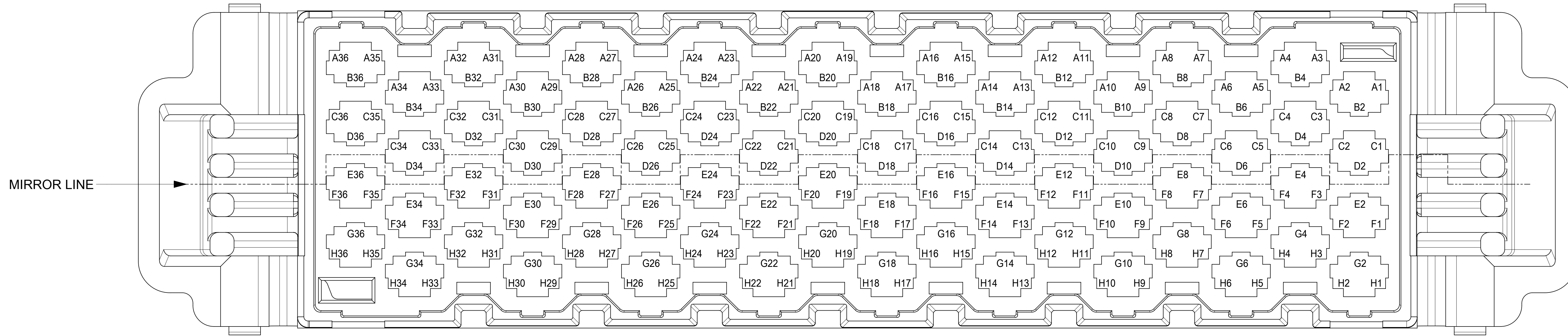

TOP VIEW OF A 4 ROW X 18 COLUMN PLUG CONTACT IDENTIFICATION AND LOCATION (B, D, E AND G ARE SHIELD CONTACTS) (TRIADS ARE NOT SHOWN)

PIN-OUT CHART FOR 1708070036 / 1708070048 PLUG (4 ROWS X 18 COLUMNS)

A36 A35 POWER	A34 A33 SIG 100	A32 A31 SIG 100	A30 A29 SIG 100	A28 A27 SIG 100	A26 A25 SIG 100	A24 A23 SIG 100	A22 A21 SIG 100	A20 A19 SIG 85	A18 A17 SIG 85	A16 A15 SIG 85	A14 A13 SIG 85	A12 A11 SIG 85	A10 A9 SIG 85	A8 A7 SIG 85	A6 A5 SIG 85	A4 A3 SIG 85	A2 A1 SIG 85
B36 B35	B34 B33	B32 B31	B30 B29	B28 B27	B26 B25	B24 B23	B22 B21	B20 B19	B18 B17	B16 B15	B14 B13	B12 B11	B10 B9	B8 B7	B6 B5	B4 B3	B2 B1
C36 C35 POWER	C34 C33 SIG 100	C32 C31 SIG 100	C30 C29 SIG 100	C28 C27 SIG 100	C26 C25 SIG 100	C24 C23 SIG 100	C22 C21 SIG 100	C20 C19 SIG 85	C18 C17 SIG 85	C16 C15 SIG 85	C14 C13 SIG 85	C12 C11 SIG 85	C10 C9 SIG 85	C8 C7 SIG 85	C6 C5 SIG 85	C4 C3 SIG 85	C2 C1 SIG 85
D36 D35	D34 D33	D32 D31	D30 D29	D28 D27	D26 D25	D24 D23	D22 D21	D20 D19	D18 D17	D16 D15	D14 D13	D12 D11	D10 D9	D8 D7	D6 D5	D4 D3	D2 D1
E36 E35 POWER	E34 E33 SIG 100	E32 E31 SIG 100	E30 E29 SIG 100	E28 E27 SIG 100	E26 E25 SIG 100	E24 E23 SIG 100	E22 E21 SIG 100	E20 E19 SIG 85	E18 E17 SIG 85	E16 E15 SIG 85	E14 E13 SIG 85	E12 E11 SIG 85	E10 E9 SIG 85	E8 E7 SIG 85	E6 E5 SIG 85	E4 E3 SIG 85	E2 E1 SIG 85
F36 F35	F34 F33	F32 F31	F30 F29	F28 F27	F26 F25	F24 F23	F22 F21	F20 F19	F18 F17	F16 F15	F14 F13	F12 F11	F10 F9	F8 F7	F6 F5	F4 F3	F2 F1
G36 G35 POWER	G34 G33 SIG 100	G32 G31 SIG 100	G30 G29 SIG 100	G28 G27 SIG 100	G26 G25 SIG 100	G24 G23 SIG 100	G22 G21 SIG 100	G20 G19 SIG 85	G18 G17 SIG 85	G16 G15 SIG 85	G14 G13 SIG 85	G12 G11 SIG 85	G10 G9 SIG 85	G8 G7 SIG 85	G6 G5 SIG 85	G4 G3 SIG 85	G2 G1 SIG 85
H36 H35	H34 H33	H32 H31	H30 H29	H28 H27	H26 H25	H24 H23	H22 H21	H20 H19	H18 H17	H16 H15	H14 H13	H12 H11	H10 H9	H8 H7	H6 H5	H4 H3	H2 H1

MIRROR LINE

BROKEN LINE INDICATES THAT THESE SOLDER POINTS ARE ELECTRICALLY COMMON WITHIN CONNECTOR

LEGEND FOR PIN-OUT CHART	
1708070036 / 1708070048 PLUG	
SYMBOL	DESCRIPTION
SIG 85	7mm 85 OHM SIGNAL TRIAD
SIG 100	7mm 100 OHM SIGNAL TRIAD
POWER	7mm POWER TRIAD

SYMBOLS	THIS DRAWING CONTAINS INFORMATION THAT IS PROPRIETARY TO MOLEX ELECTRONIC TECHNOLOGIES, LLC AND SHOULD NOT BE USED WITHOUT WRITTEN PERMISSION	
	DIMENSION UNITS	SCALE
▽ = 0	mm	NTS
▽ = 0	GENERAL TOLERANCES (UNLESS SPECIFIED)	
▽ = 0	ANGULAR TOL ± 0.5°	
▽ = 0	4 PLACES	±
▽ = 0	3 PLACES	±
▽ = 0	2 PLACES	± 0.15
▽ = 0	1 PLACE	±
▽ = 0	0 PLACES	±
■ = 0	DRAFT WHERE APPLICABLE MUST REMAIN WITHIN DIMENSIONS	
▽ = 0	THIRD ANGLE PROJECTION	

CURRENT REV DESC: SAME AS REV A2	
EC NO: 614258	2019/03/21
DRWN: HCGOH	2019/03/22
CHK'D: CLHOE01	2019/03/22
APPR: SHONG	2019/03/25
INITIAL REVISION:	
DRWN: KPELOZA	2014/02/28
APPR: SHONG	2014/06/02

DOCUMENT NUMBER		DOC TYPE	DOC PART	REVISION
SD-170807-0036		PSD	001	A3

DOCUMENT STATUS	P1	RELEASE DATE	2019/03/25 04:33:53
-----------------	----	--------------	---------------------

DRAWING	SERIES	MATERIAL NUMBER	CUSTOMER	SHEET NUMBER
D-SIZE	170807	SEE TABLE	GENERAL MARKET	3 OF 4

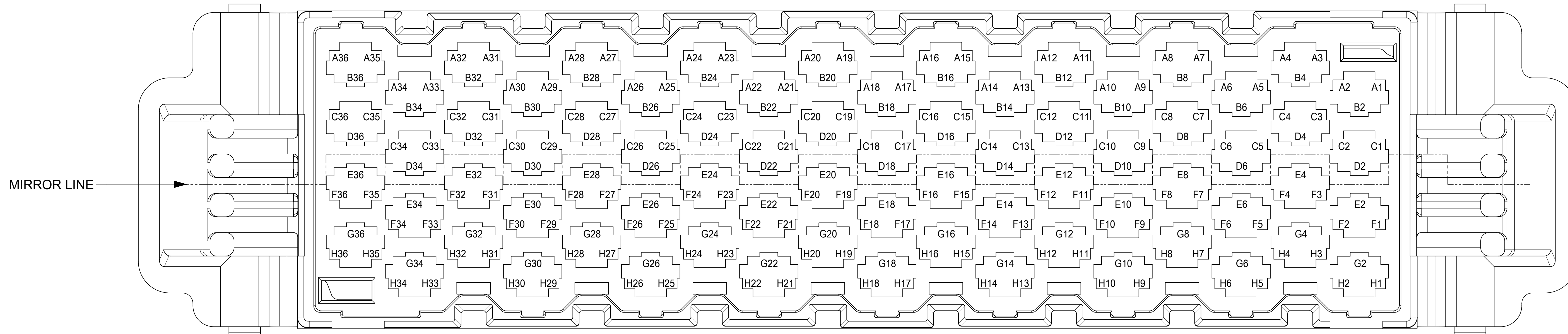

TOP VIEW OF A 4 ROW X 18 COLUMN PLUG CONTACT IDENTIFICATION AND LOCATION (B, D, E AND G ARE SHIELD CONTACTS) (TRIADS ARE NOT SHOWN)

PIN-OUT CHART FOR 1708073005 PLUG (4 ROWS X 18 COLUMNS)

A36 A35 SIG 85 B36 B35	A34 A33 SIG 85 B34 B33	A32 A31 SIG 85 B32 B31	A30 A29 SIG 85 B30 B29	A28 A27 SIG 85 B28 B27	A26 A25 SIG 85 B26 B25	A24 A23 SIG 85 B24 B23	A22 A21 SIG 85 B22 B21	A20 A19 SIG 85 B20 B19	A18 A17 SIG 85 B18 B17	A16 A15 SIG 85 B16 B15	A14 A13 SIG 85 B14 B13	A12 A11 SIG 85 B12 B11	A10 A9 SIG 85 B10 B9	A8 A7 SIG 85 B8 B7	A6 A5 SIG 85 B6 B5	A4 A3 SIG 85 B4 B3	A2 A1 POWER B2 B1
C36 C35 SIG 85 D36 D35	C34 C33 SIG 85 D34 D33	C32 C31 SIG 85 D32 D31	C30 C29 SIG 85 D30 D29	C28 C27 SIG 85 D28 D27	C26 C25 SIG 85 D26 D25	C24 C23 SIG 85 D24 D23	C22 C21 SIG 85 D22 D21	C20 C19 SIG 85 D20 D19	C18 C17 SIG 85 D18 D17	C16 C15 SIG 85 D16 D15	C14 C13 SIG 85 D14 D13	C12 C11 SIG 85 D12 D11	C10 C9 SIG 85 D10 D9	C8 C7 SIG 85 D8 D7	C6 C5 SIG 85 D6 D5	C4 C3 SIG 85 D4 D3	C2 C1 POWER D2 D1
E36 E35 SIG 85 F36 F35	E34 E33 SIG 85 F34 F33	E32 E31 SIG 85 F32 F31	E30 E29 SIG 85 F30 F29	E28 E27 SIG 85 F28 F27	E26 E25 SIG 85 F26 F25	E24 E23 SIG 85 F24 F23	E22 E21 SIG 85 F22 F21	E20 E19 SIG 85 F20 F19	E18 E17 SIG 85 F18 F17	E16 E15 SIG 85 F16 F15	E14 E13 SIG 85 F14 F13	E12 E11 SIG 85 F12 F11	E10 E9 SIG 85 F10 F9	E8 E7 SIG 85 F8 F7	E6 E5 SIG 85 F6 F5	E4 E3 SIG 85 F4 F3	E2 E1 POWER F2 F1
G36 G35 SIG 85 H36 H35	G34 G33 SIG 85 H34 H33	G32 G31 SIG 85 H32 H31	G30 G29 SIG 85 H30 H29	G28 G27 SIG 85 H28 H27	G26 G25 SIG 85 H26 H25	G24 G23 SIG 85 H24 H23	G22 G21 SIG 85 H22 H21	G20 G19 SIG 85 H20 H19	G18 G17 SIG 85 H18 H17	G16 G15 SIG 85 H16 H15	G14 G13 SIG 85 H14 H13	G12 G11 SIG 85 H12 H11	G10 G9 SIG 85 H10 H9	G8 G7 SIG 85 H8 H7	G6 G5 SIG 85 H6 H5	G4 G3 SIG 85 H4 H3	G2 G1 POWER H2 H1

MIRROR LINE

BROKEN LINE INDICATES THAT THESE SOLDER POINTS ARE ELECTRICALLY COMMON WITHIN CONNECTOR

LEGEND FOR PIN-OUT CHART	
1708073005 PLUG	
SYMBOL	DESCRIPTION
SIG 85	7mm 85 OHM SIGNAL TRIAD
POWER	7mm POWER TRIAD

SYMBOLS	THIS DRAWING CONTAINS INFORMATION THAT IS PROPRIETARY TO MOLEX ELECTRONIC TECHNOLOGIES, LLC AND SHOULD NOT BE USED WITHOUT WRITTEN PERMISSION	
	DIMENSION UNITS	SCALE
▽ = 0	mm	NTS
▽ = 0	GENERAL TOLERANCES (UNLESS SPECIFIED)	
▽ = 0	ANGULAR TOL	± 0.5°
▽ = 0	4 PLACES	±
▽ = 0	3 PLACES	±
▽ = 0	2 PLACES	± 0.15
▽ = 0	1 PLACE	±
▽ = 0	0 PLACES	±
■ = 0	DRAFT WHERE APPLICABLE MUST REMAIN WITHIN DIMENSIONS	
▽ = 0	THIRD ANGLE PROJECTION	
CURRENT REV DESC: SAME AS REV A2		
EC NO: 614258		
DRWN: HCGOH		2019/03/21
CHK'D: CLHOE01		2019/03/22
APPR: SHONG		2019/03/25
INITIAL REVISION:		
DRWN: KPELOZA		2014/02/28
APPR: SHONG		2014/06/02
D-DRAWING		SERIES
D-SIZE		170807
MATERIAL NUMBER		CUSTOMER
SEE TABLE		GENERAL MARKET
DOCUMENT NUMBER		DOC TYPE DOC PART REVISION
SD-170807-0036		PSD 001 A3
SHEET NUMBER		4 OF 4

**molex**

PLUG  
4X18 NEOSCALE, BLIND MATE

PRODUCT CUSTOMER DRAWING

DOCUMENT NUMBER: SD-170807-0036  
DOC TYPE: PSD  
DOC PART: 001  
REVISION: A3