

Type RQ73 Series

Key Features

SMD TaN Thin film resistor

Special passivation layer on resistive element

AEC-Q200 qualified

Sulfur resistant (per ASTM B809-95 humid vapor test)

RoHS Compliant



TE Connectivity is proud to introduce this automotive grade thin film precision chip resistor, a sister to our highly successful RN73 range. The resistors are constructed in a high grade raw materials and laser trimmed to give precise tolerance figures. This, coupled with the tight TCR and anti-corrosive protection layer gives us a range of resistors which are ideal not just for automotive applications, but also for medical equipment, measuring instruments and industrial applications.

Characteristics – Electrical

| Type | RQ73 1E | RQ73 1J | RQ73 2A | RQ73 2B |
|---|-------------|------------|------------|-----------|
| Size | 0402 | 0603 | 0805 | 1206 |
| Resistance tolerance | ±0.1% | | | |
| Resistance Range | 40R ~ 35K | 40R ~ 130K | 10R ~ 350K | 10R ~ 1M0 |
| TCR (ppm/°C) | ±10PPM/°C | | | |
| Max. dissipation at Tamb=85°C | 0.0625W | 0.15W | 0.2W | 0.4W |
| Max. Working Voltage (DC or RMS) ^{1 2} | 50V | 75V | 100V | 200V |
| Max. Overload Voltage (DC or RMS) | 100V | 150V | 200V | 400V |
| Operating Temperature | -55 ~ 155°C | | | |

Notes:

- This is the maximum voltage that may be continuously supplied to the resistor element, see "IEC publication 60115-8"
- Max. Operation Voltage : So called RCWV (Rated Continuous Working Voltage) determined by

$$RCWV = \sqrt{\text{Rated Power} \times \text{Resistance Value}} \text{ or Max. RCWV listed above, whichever is lower.}$$

Construction

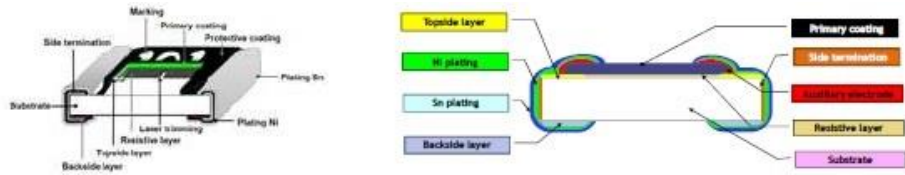

Dimensions: (mm)

| Type | RQ73 1E | RQ73 1J | RQ73 2A | RQ73 2B |
|------|-------------|-------------|-------------|-------------|
| L | 1.00 ± 0.10 | 1.55 ± 0.10 | 2.00 ± 0.10 | 3.10 ± 0.10 |
| W | 0.50 ± 0.05 | 0.80 ± 0.10 | 1.25 ± 0.10 | 1.60 ± 0.10 |
| A | 0.25 ± 0.15 | 0.3 ± 0.20 | 0.35 ± 0.20 | 0.40 ± 0.20 |
| B | 0.30 ± 0.10 | 0.30 ± 0.15 | 0.40 ± 0.20 | 0.40 ± 0.20 |
| t | 0.30 ± 0.10 | 0.45 ± 0.15 | 0.50 ± 0.15 | 0.60 ± 0.15 |

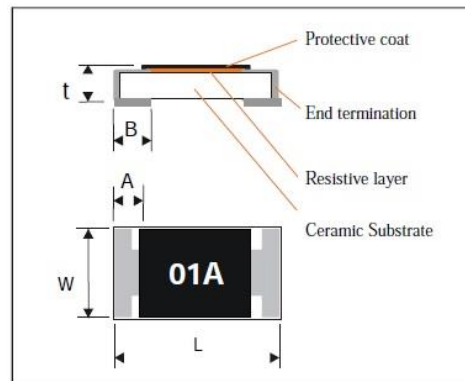

Derating Curve

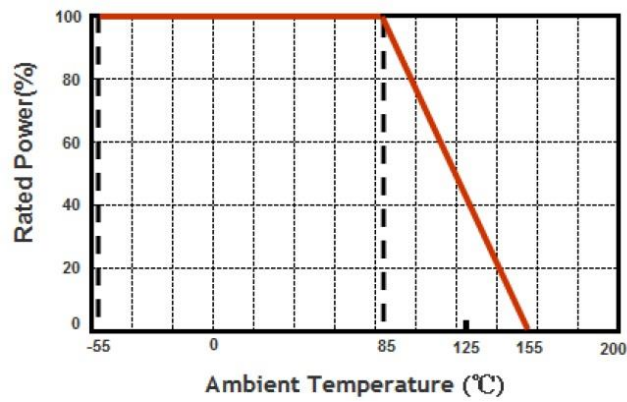

Environmental Characteristics

| Test | Procedure | Requirement |
|---|---|--|
| Electrical Characteristics IEC 60115-1 4.8 | - DC resistance values measurement - Temperature Coefficient of Resistance (T.C.R) Natural resistance change per change in degree centigrade. $\frac{R_2 - R_1}{R_1(t_2 - t_1)} \times 10^6 \text{ (ppm/}^\circ\text{C)}$ $t_1 : 20^\circ\text{C} \pm 5^\circ\text{C} - 1^\circ\text{C}$ R_1 : Resistance at reference temperature ($20^\circ\text{C} \pm 5^\circ\text{C} - 1^\circ\text{C}$) R_2 : Resistance at test temperature (-55°C or $+125^\circ\text{C}$) | Within Specified Tolerance |
| Short time overload (S.T.O.L) IEC60115-1 4.13 | Permanent resistance change after a 5 second application of a voltage 2.5 times RCWV or the maximum overload voltage specified in the above list, whichever is less. | $\Delta R/R$ max. $\pm(0.1\%+0.02\Omega)$ |
| Resistance to soldering heat (R.S.H) AEC Q200-15 | Un-mounted chips completely immersed for 10 ± 1 second in a SAC solder bath at $260^\circ\text{C} \pm 5^\circ\text{C}$ | no visible damage $\Delta R/R$ max. $\pm(0.1\%+0.02\Omega)$ |
| Solderability IEC 60068-2-58 | Un-mounted chips completely immersed for 2 ± 0.5 second in a SAC solder bath at $235^\circ\text{C} \pm 5^\circ\text{C}$ | good tinning (>95% covered) no visible damage |
| Temperature Cycling JESD22 method JA-104 | 1000 cycles $-55 \sim 125^\circ\text{C}$, dwell time 5 – 10 min. | no visible damage $\Delta R/R$ max. $\pm(0.1\%+0.02\Omega)$ |
| | 1000 cycles $-55 \sim 155^\circ\text{C}$, dwell time 5 – 10 min. | no visible damage $\Delta R/R$ max. $\pm(0.2\%+0.02\Omega)$ |
| Bias Humidity AEC Q200-7 | 1000 $+48/-0$ hours, loaded with 10% rated power in humidity chamber controlled at $+85^\circ\text{C}/85\% \text{RH}$ | $\Delta R/R$ max. $\pm(0.1\%+0.02\Omega)$ |
| Load Life IEC60115-1 4.25 | 1000 $+48/-0$ hours, loaded with RCWV or V_{max} in chamber controlled at $85 \pm 2^\circ\text{C}$, 1.5 hours on and 0.5 hours off | $\Delta R/R$ max. $\pm(0.1\%+0.02\Omega)$ |
| Operational Life AEC Q200-8 MIL-STD-202 -108 | 1,000 hours at $125 \pm 2^\circ\text{C}$, loaded with rated power continuously | $\Delta R/R$ max. $\pm(0.1\%+0.02\Omega)$ |
| High Temperature Exposure AEC Q200-3 | 1000 hrs @ 125°C , un-powered | $\Delta R/R$ max. $\pm(0.1\%+0.02\Omega)$ |
| | 1000 hrs @ 155°C , un-powered | $\Delta R/R$ max. $\pm(0.15\%+0.02\Omega)$ |
| Moisture Resistance AEC-Q200 -6 MIL-STD-202 Method 106 | $65 \pm 2^\circ\text{C}$, $80 \sim 100\% \text{RH}$, 10 cycles, 24 hours/ cycle | $\Delta R/R$ max. $\pm(0.1\%+0.02\Omega)$ |
| Mechanical Shock MIL-STD-202 Method 213 | 1/2 Sine Pulse / 1500g Peak / Velocity 15.4ft/sec | $\Delta R/R$ max. $\pm(0.1\%+0.02\Omega)$ |
| Vibration MIL-STD-202 Method 204 | 5 g's for 20 min , 12 cycles each of 3 orientations | $\Delta R/R$ max. $\pm(0.1\%+0.02\Omega)$ |
| Terminal strength AEC-Q200-6 | 1 kg for 60 s | No Physical Damage |
| Board flex AEC-Q200-21 | Bending 2mm for 60 sec | $\Delta R/R$ max. $\pm(0.1\%+0.02\Omega)$ |
| Flower of sulfur test ASTM B809 - 95 | $105 \pm 2^\circ\text{C}$, Duration 1,000 hours | 0402 $\Delta R/R$ max. $\pm(0.2\%+0.02\Omega)$ Others $\Delta R/R$ max. $\pm(0.1\%+0.02\Omega)$ |

Marking:

0603 E24 series 3 Digits – first two digits denote significant figures of resistance and third digit denotes number of zeros thereafter. EG

| | | |
|--|-----|--|
| | 222 | |
|--|-----|--|

 =
 2K2

0603 E96 series 3 Digits - The 1st two digit codes are referring to the CODE in the table, the 3rd code is the index of resistance value :

$Y=10^{-2}$, $X=10^{-1}$, $A=10^0$, $B=10^1$, $C=10^2$, $D=10^3$, $E=10^4$, $F=10^5$

EX : $17.8\Omega=25X$, $178\Omega=25A$, $1K78 =25B$

$17K8=25C$, $178K=25D$, $1M78=25E$

| CODE | R_value | CODE | R_value | CODE | R_value | CODE | R_value | CODE | R_value | CODE | R_value | CODE | R_value | CODE | R_value |
|------|---------|------|---------|------|---------|------|---------|------|---------|------|---------|------|---------|------|---------|
| 01 | 100 | 13 | 133 | 25 | 178 | 37 | 237 | 49 | 316 | 61 | 422 | 73 | 562 | 85 | 750 |
| 02 | 102 | 14 | 137 | 26 | 182 | 38 | 243 | 50 | 324 | 62 | 432 | 74 | 576 | 86 | 768 |
| 03 | 105 | 15 | 140 | 27 | 187 | 39 | 249 | 51 | 332 | 63 | 442 | 75 | 590 | 87 | 787 |
| 04 | 107 | 16 | 143 | 28 | 191 | 40 | 255 | 52 | 340 | 64 | 453 | 76 | 604 | 88 | 806 |
| 05 | 110 | 17 | 147 | 29 | 196 | 41 | 261 | 53 | 348 | 65 | 464 | 77 | 619 | 89 | 825 |
| 06 | 113 | 18 | 150 | 30 | 200 | 42 | 267 | 54 | 357 | 66 | 475 | 78 | 634 | 90 | 845 |
| 07 | 115 | 19 | 154 | 31 | 205 | 43 | 274 | 55 | 365 | 67 | 487 | 79 | 649 | 91 | 866 |
| 08 | 118 | 20 | 158 | 32 | 210 | 44 | 280 | 56 | 374 | 68 | 499 | 80 | 665 | 92 | 887 |
| 09 | 121 | 21 | 162 | 33 | 215 | 45 | 287 | 57 | 383 | 69 | 511 | 81 | 681 | 93 | 909 |
| 10 | 124 | 22 | 165 | 34 | 221 | 46 | 294 | 58 | 392 | 70 | 523 | 82 | 698 | 94 | 931 |
| 11 | 127 | 23 | 169 | 35 | 226 | 47 | 301 | 59 | 402 | 71 | 536 | 83 | 715 | 95 | 953 |
| 12 | 130 | 24 | 174 | 36 | 232 | 48 | 309 | 60 | 412 | 72 | 549 | 84 | 732 | 96 | 976 |

0805 & 1206 E24 and E96 4 digits – Where value is below 100R use R as decimal, otherwise three significant figures plus number of following zeros.

E.G.

| Resistance | 10 Ω | 12 Ω | 100 Ω | 6K8 | 47K |
|-----------------|-------------|-------------|--------------|------|------|
| 4 digit marking | 10R0 | 12R0 | 1000 | 6801 | 4702 |

Notes:

1. No marking for non-E24/E96 resistance values.
2. No marking for 0402 size resistors

Packaging

Paper Tape Specification (mm)

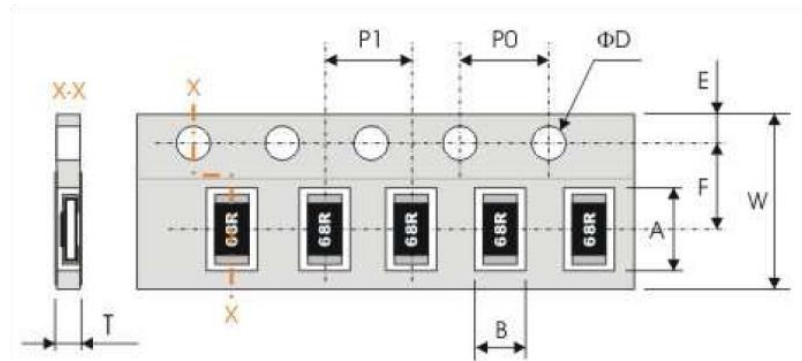

| Size | A | B | W | F | E |
|------|-----------|-----------|-----------|-----------|-----------|
| 0402 | 1.20±0.10 | 0.7±0.10 | 8.00±0.30 | 3.50±0.05 | 1.75±0.10 |
| 0603 | 1.90±0.20 | 1.10±0.20 | 8.00±0.30 | 3.50±0.20 | 1.75±0.10 |
| 0805 | 2.40±0.20 | 1.65±0.20 | 8.00±0.30 | 3.50±0.20 | 1.75±0.10 |
| 1206 | 3.60±0.20 | 2.00±0.20 | 8.00±0.30 | 3.50±0.20 | 1.75±0.10 |

| Size | P1 | P0 | ØD | T |
|------|-----------|-----------|---------------------------------------|-----------|
| 0402 | 2.00±0.10 | 4.00±0.10 | Ø1.50 ^{+0.1} _{-0.0} | 0.40±0.05 |
| 0603 | 4.00±0.10 | 4.00±0.10 | Ø1.50 ^{+0.1} _{-0.0} | 0.65±0.05 |
| 0805 | 4.00±0.10 | 4.00±0.10 | Ø1.50 ^{+0.1} _{-0.0} | Max. 1.0 |
| 1206 | 4.00±0.10 | 4.00±0.10 | Ø1.50 ^{+0.1} _{-0.0} | Max. 1.0 |

Reel Dimensions (mm)

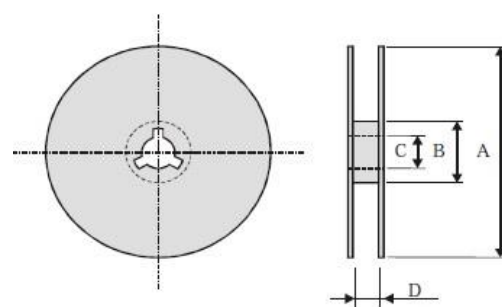

| Symbol | A | B | C | D |
|-----------|------------|-----------|----------|---------|
| Dim. (mm) | Ø178.0±2.0 | Ø60.0±1.0 | 13.0±0.2 | 9.0±0.5 |

All sizes 5,000 pieces per reel

Storage and Handling Condition:

1. Products are recommended to be used up within two years. Check solderability in case shelf life extension is needed.
2. To store products with following condition:
Temperature : 5 to 40°C
Humidity : 20 to 70% relative humidity
3. Caution:
 - a. Don't store products in a corrosive environment such as sulfide, chloride gas, or acid. It may cause oxidation of electrode, which easily be resulted in poor soldering.
 - b. To store products on the shelf and avoid exposure to moisture.
 - c. Don't expose products to excessive shock, vibration, direct sunlight etc.

MOUNTING

Due to their rectangular shapes and small tolerances, Surface Mountable Resistors are suitable for handling by automatic placement systems.

Chip placement can be on ceramic substrates and printed-circuit boards (PCBs).

Electrical connection to the circuit is by individual soldering condition.

The end terminations guarantee a reliable contact.

SOLDERING CONDITION

The robust construction of chip resistors allows them to be completely immersed in a solder bath of 260°C for 10 seconds. Therefore, it is possible to mount Surface Mount Resistors on one side of a PCB and other discrete components on the reverse (mixed PCBs).

Surface Mount Resistors are tested for solderability at 235°C during 2 seconds within lead-free solder bath. The test condition for no leaching is 260°C for 30 seconds.

Typical examples of soldering profile and condition that provide reliable joints without any damage are given below.

Infrared soldering condition for Chip Resistors

| Temperature Condition | Exposure time |
|---------------------------------------|-----------------------------|
| Average ramp-up rate (217°C to 260°C) | Less than 3°C/second |
| Between 150 and 200°C | Between 60-120 seconds |
| > 217°C | Between 60-150 seconds |
| Peak Temperature | 260°C +0/-5°C |
| Time within 245°C | Min. 30 seconds |
| Ramp-down rate (Peak to 217°C) | Less than 6°C/second |
| Time from 25°C to Peak | No greater than 480 seconds |

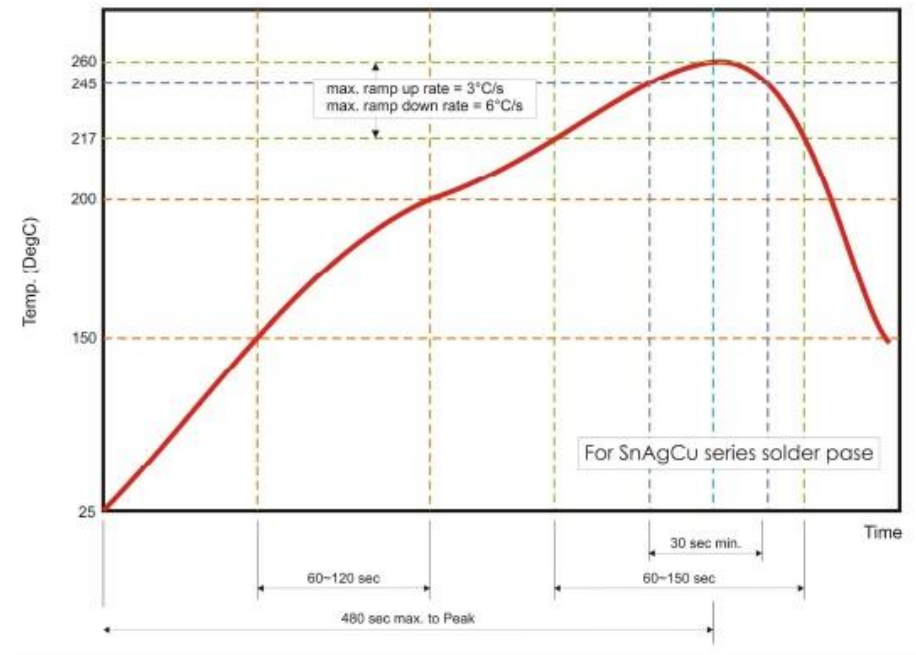

Infrared soldering profile for Chip Resistors

How To Order

RQ73 C 1E 40R2 B TDF

| Common Part | TCR | Size Code | Resistance Value | Tolerance | Packaging Spec. |
|-------------|--------------|--|---|-----------|-----------------------------------|
| RQ73 | C = 10PPM/°C | 1E = 0402 1J = 0603 2A = 0805 2B = 1206 | 100R (100Ω) 1K0 (1000Ω) 100K (100,000Ω) | B = .1% | TD = Reel 5000 TDF = Reel 1000 |