

THIS DRAWING IS UNPUBLISHED. RELEASED FOR PUBLICATION
 © COPYRIGHT 2005 By - ALL RIGHTS RESERVED.

LOC		DIST		REVISIONS			
P	LTR	DESCRIPTION		DATE	DWN	APVD	
GP	00	D		REVISED PER ECO-14-011808	09AUG2014	AP	SB

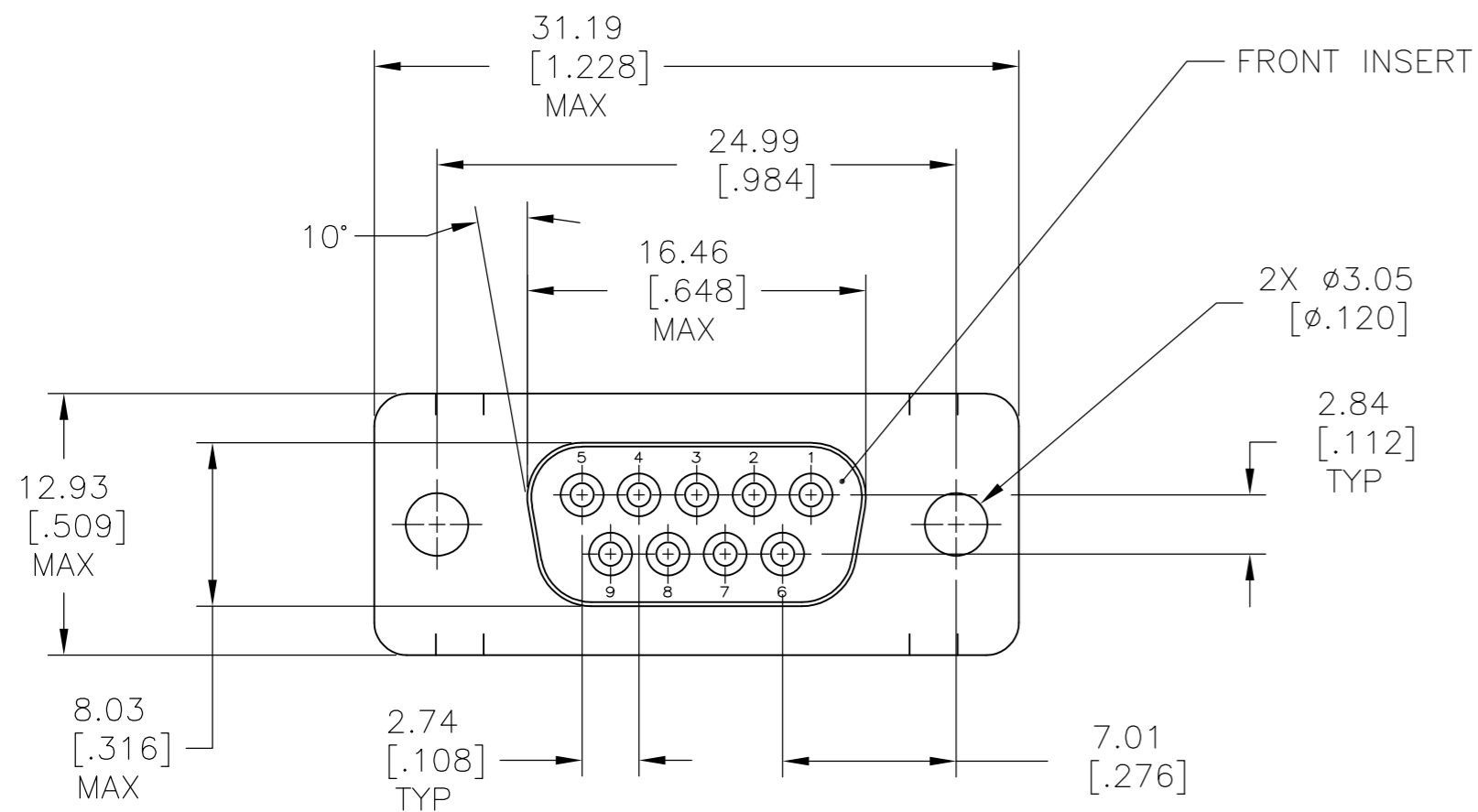

- 1 MOLDED PARTS: GLASS-FILLED PBT OR GLASS-FILLED NYLON, UL94V-0 RATED.
 COLOR: BLACK
 SHELLS: CARBON STEEL.
 CONTACTS: PHOS BRONZE.
- 2 SHELLS: 5.08µm [.000200] MIN ZINC WITH YELLOW CHROMATE COATING.
 CONTACTS: GOLD FLASH PLATED FOR LENGTH OF 3.81 [.150] MIN FROM MATING END,
 2.54µm [.000100] MIN TIN ON SOLDER END, BOTH OVER
 1.27µm [.000050] MIN NICKEL.
- 3 SHELLS: 5.08µm [.000200] MIN ZINC WITH YELLOW CHROMATE COATING.
 CONTACTS: GOLD PLATED FOR LENGTH OF 3.81 [.150] MIN FROM MATING END,
 0.76µm [.000030] MIN GOLD IN MATED AREA,
 2.54µm [.000100] MIN TIN ON SOLDER END, BOTH OVER
 1.27µm [.000050] MIN NICKEL.
 OR
 GOLD FLASH OVER PALLADIUM-NICKEL PLATED FOR LENGTH OF
 3.81 [.150] MIN FROM MATING END,
 0.76µm [.000030] MIN TOTAL IN MATED AREA,
 2.54µm [.000100] MIN TIN ON SOLDER END, BOTH OVER
 1.27µm [.000050] MIN NICKEL.

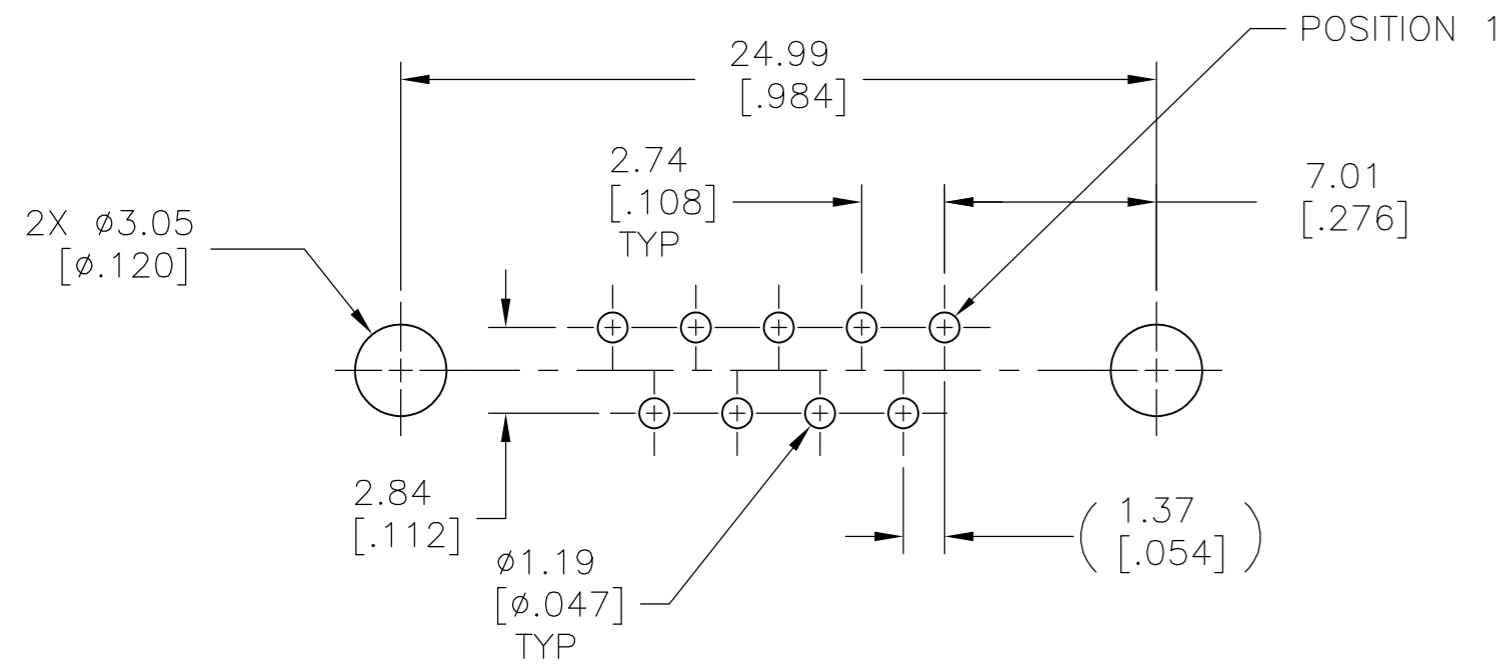
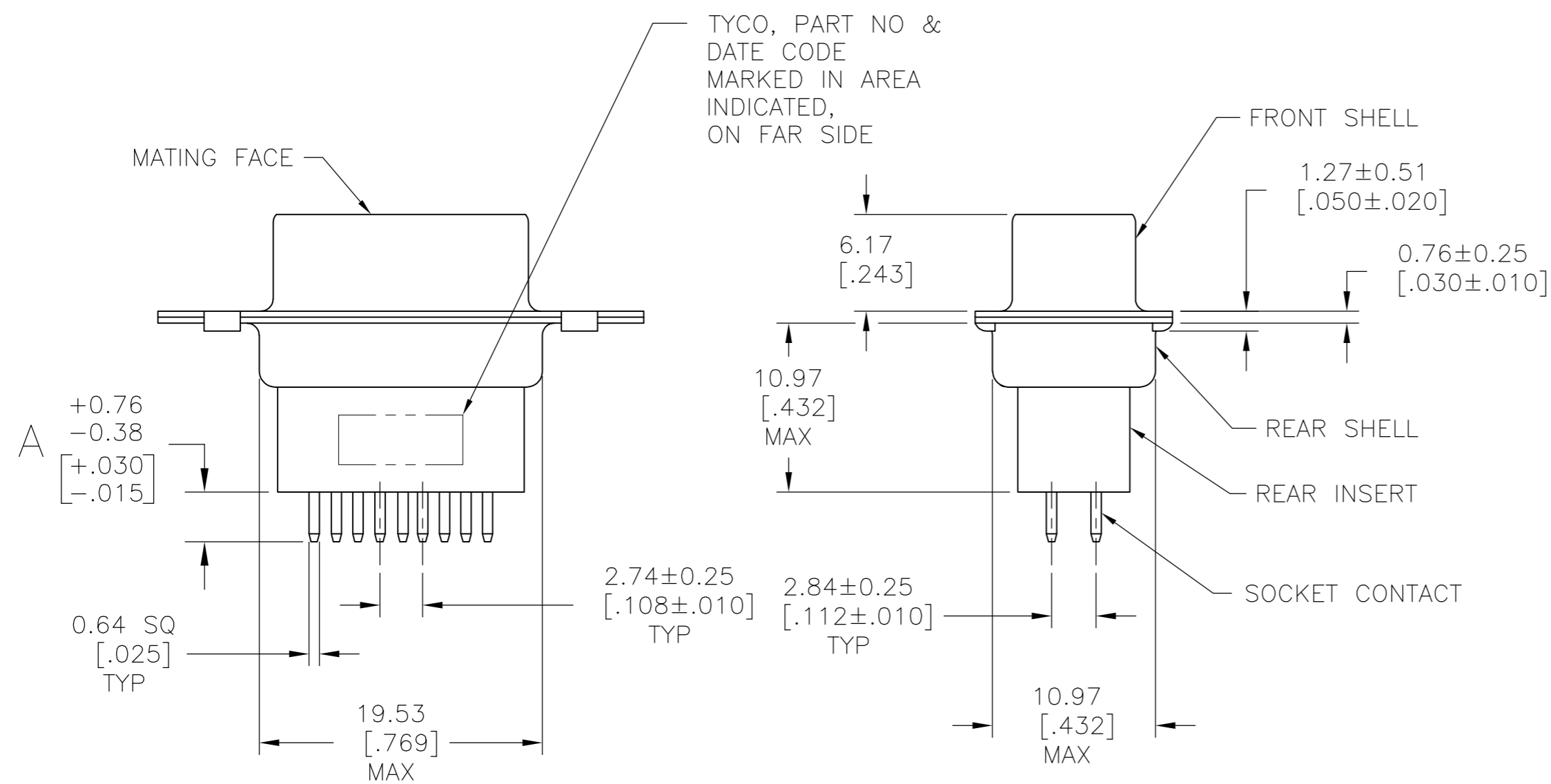

P.C. BOARD MOUNTING DIMENSIONS

3	4.78 [.188]	5205734-7
3	16.54 [.651]	5205734-5
2	10.85 [.427]	5205734-4
3	3.18 [.125]	5205734-1
GOLD FINISH		A
		PART NO

THIS DRAWING IS A CONTROLLED DOCUMENT.		DWN B. LATTUCA 02SEPT05		
DIMENSIONS: mm [INCHES]		CHK S. BOLASH 02SEPT05		
TOLERANCES UNLESS OTHERWISE SPECIFIED:		APVD M. WALMSLEY 02SEPT05	NAME	
0 PLC ± -		PRODUCT SPEC	RECEPTACLE ASSEMBLY, SIZE 1, 9 POSN, VERTICAL, AMPLIMITE HDP	
1 PLC ± -		108-40025	-	
2 PLC ± -		APPLICATION SPEC	-	
3 PLC ± .005		114-40013	SIZE A2	CAGE CODE 00779
4 PLC ± -		WEIGHT -	DRAWING NO	RESTRICTED TO
ANGLES ± -			C=5205734	
FINISH			SCALE NTS	SHEET 1 of 1
1		CUSTOMER DRAWING		REV D