



Electrical Specifications

Operating Conditions

PARAMETER	SYMBOL	CONDITIONS	MIN	TYP	MAX	UNIT
Maximum Supply Voltage	V _{CC}	-	-0.6	-	4.6	V
Maximum Control Voltage	V _C	-	-0.5	-	V _{CC}	V
Supply Voltage	V _{CC}	±5%	2.36	2.5	2.63	
			2.85	3.0	3.15	V
			3.14	3.3	3.47	
Supply Current	I _{CC}	Typical Measured @ 26MHz	-	3.0	6.0	mA
Output Load	R _L //C _L	-	10k Ohm//10pF		-	-
Operating Temperature	T _A	-	0		+50	
			-10		+60	
			-20	+25	+70	°C
			-30		+85	
			-40		+85	
Storage Temperature	T _{STG}	-	-40	-	+85	°C

Frequency Stability

PARAMETER	SYMBOL	CONDITIONS	MIN	TYP	MAX	UNIT
Frequency Range	f ₀	-		10 - 52		MHz
Frequency Stability						
Overall Frequency Stability	Δf/f ₀	Reference to f ₀ , Including 20 Years Aging	-4.6	-	4.6	ppm
Initial Calibration		Calibration @ +25°C, At Time of Shipment	-0.8	-	0.8	ppm
Temperature Only ¹	Δf/f ₂₅	[F _{max} - F _{min}]/2, Over -40°C to +85°C	-0.28	-	0.28	ppm
Voltage Coefficient	Δf/f ₂₅	Supply Voltage, ±5%	-0.16	-	0.16	ppm
Load Coefficient		Load, ±10%	-0.30	-	0.30	ppm
Aging	Δf/f ₂₅	20 Years @ +40°C, Nominal V _{CC} and V _C	-3.0	-	3.0	ppm
Holdover	Δf/f ₀	[F _{max} - F _{min}]/2, Over 24 Hours	-0.4	-	0.4	ppm

1.] See Ordering Information for additional stability options.

Output Parameters

PARAMETER	SYMBOL	CONDITIONS	MIN	TYP	MAX	UNIT
Output Type	-	DC Coupled		Clipped Sine		-
Output Voltage Levels	V _O	-	0.8	-	-	V _{p-p}
Output Duty Cycle	SYM	@ 50% Level	45	-	55	%
Start Up Time	T _S	-	-	5	10	ms
Enable Function Standby						
Enable Input Voltage	V _{IH}	Pin 6 Logic '1', Output Enabled	0.7V _{CC}	-	-	V
Disable Input Voltage	V _{IL}	Pin 6 Logic '0', Output Disabled	-	-	0.3V _{CC}	V
Enable Current	I _{STB}	Pin 6 Logic '0', Output Disabled	-	-	10	μA
Enable Time	T _{PLZ}	Pin 6 Logic '1'	-	-	10	ms
Phase Noise	-	See Typical Plots	-	-	-	-

Electrical Specifications

Control Voltage

PARAMETER	SYMBOL	CONDITIONS	MIN	TYP	MAX	UNIT
Control Voltage	V_c	Nominal V_{cc}	0.5	1.5	2.5	V
Frequency Tuning [VCTCXO Only]	$\Delta f/f_0$	Specified V_c Range	± 5	-	± 15	ppm
Linearity	L	Best Straight Line Fit	-	-	± 10	%
Input Impedance	Z_{Vc}	-	100	-	-	kOhms
Transfer Function	-	-	-	Positive	-	-

Enable Truth Table

Pin 6	Pin 5
Logic '1'	Output Enabled
Open	Output Enabled
Logic '0'	Output Disabled, High Impedance

Test Circuit

Clipped Sine – w/o Enable Function

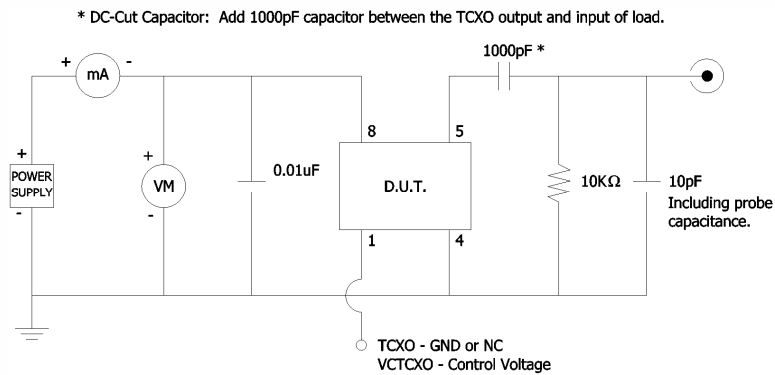

Clipped Sine – w/ Enable Function

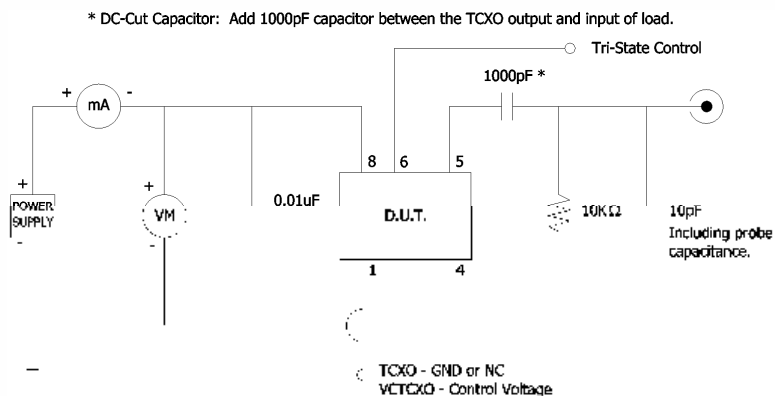

Electrical Specifications

Performance Data

Phase Noise [typical]

24.5760MHz, $V_{CC} = +3.3V$, $T_A = +25^\circ C$

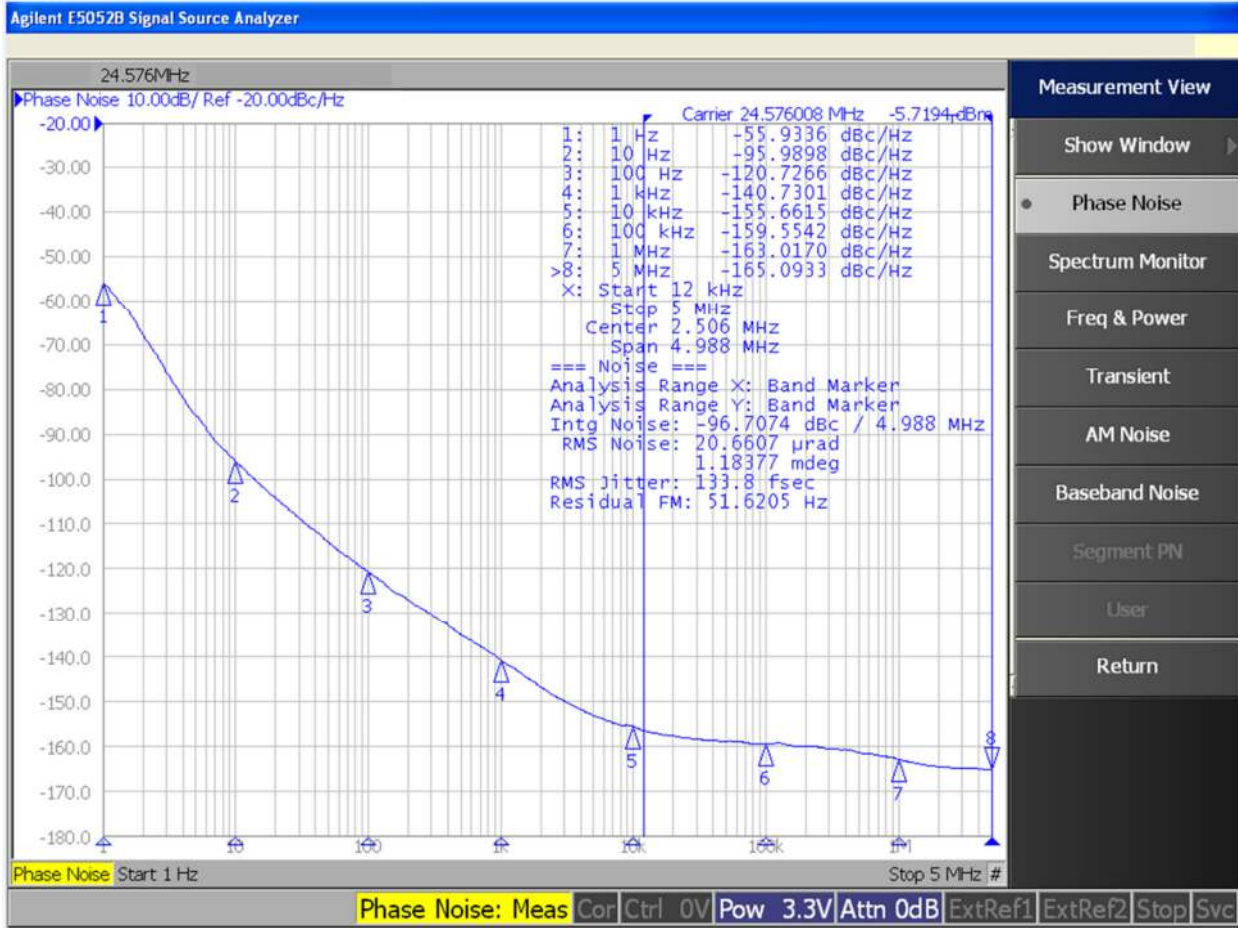

Electrical Specifications

Performance Data

Phase Noise [typical]

40MHz, $V_{CC} = +3.3V$, $V_C = +1.5V$, $T_A = +25^\circ C$

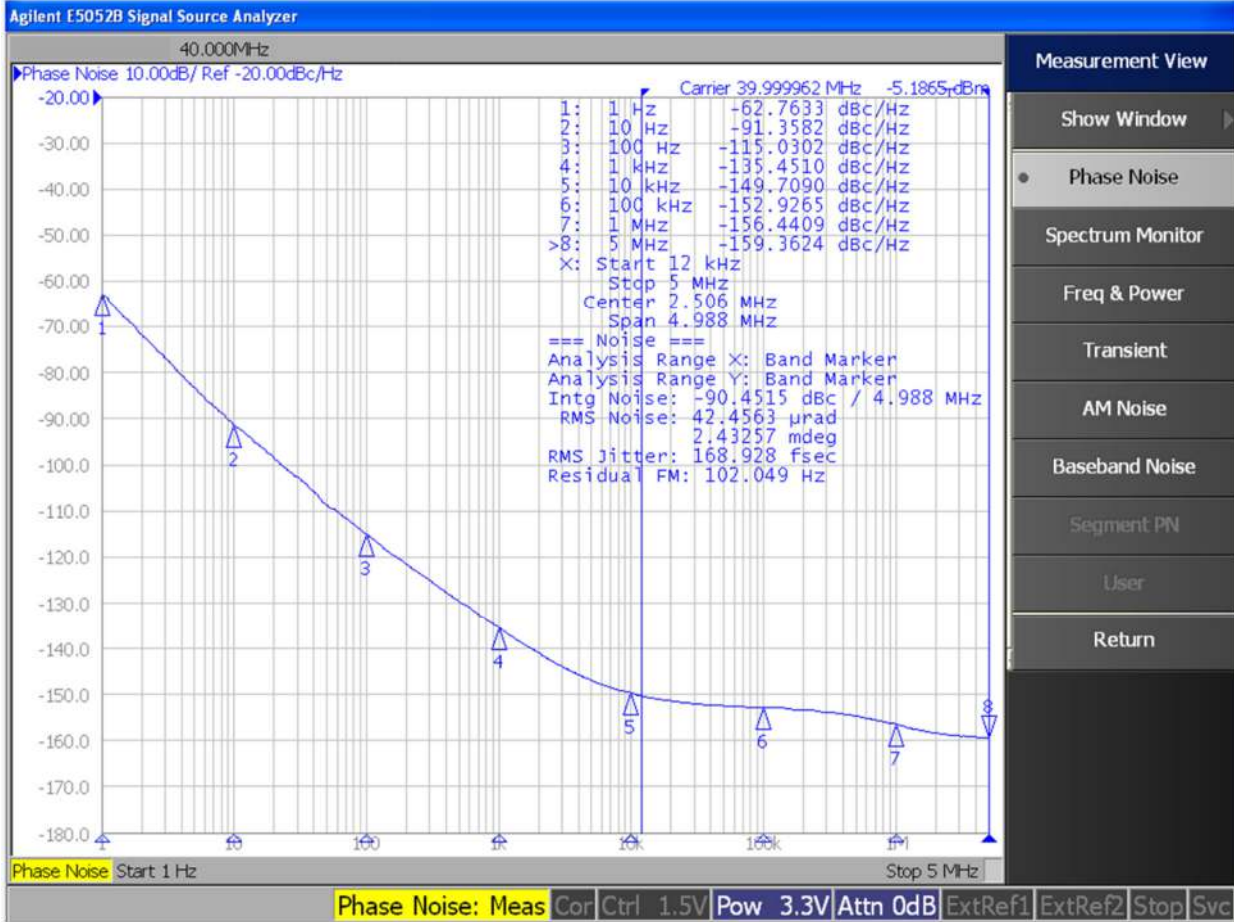

Mechanical Specifications

Package Drawing – 8-Pad

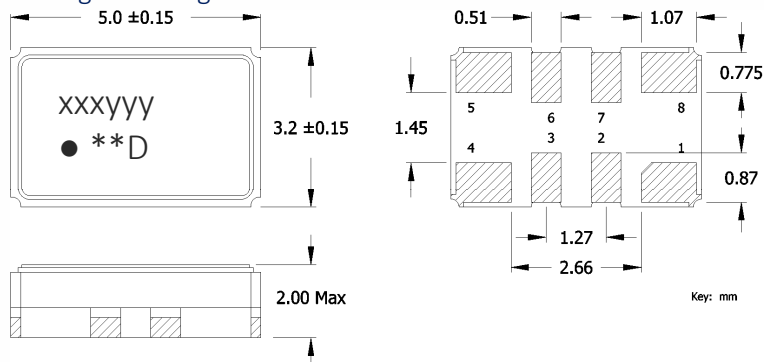

Marking Information

- xxx – Frequency Code, 3-digits.
3-digits for frequencies <100MHz
[See document 016-1454-0, Frequency Code Tables.]
- yyy – Crystal Lot Code or Date Code [optional].
- – Pin 1 Identifier.
- ** – Manufacturing site code.
- D – Date Code. See Table I for codes.

Recommended Pad Layout – w/o Enable Function

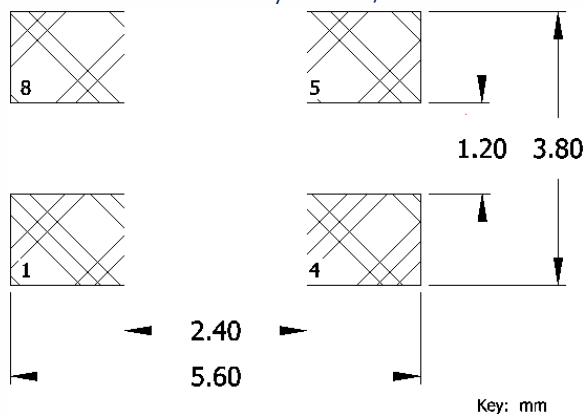

Notes

- DO NOT make connections to non-labeled pins or castellations as they may have internal connections used in the manufacturing process.
- JEDEC termination code (e4). Barrier-plating is nickel [Ni] with gold [Au] flash plate.
- Reflow conditions per JEDEC J-STD-020; +260°C maximum, 20 seconds.
- MSL = 1.

Recommended Pad Layout – w/ Enable Function

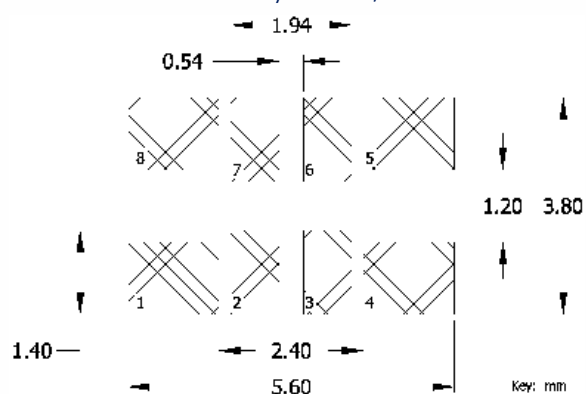



Mechanical Specifications

Pin Assignments – 8-Pad Solder Attach

Pin	Symbol	Function
1	V _C	GND or NC – TCXO [Note 1] Control Voltage – VCTCXO
2	NC	No Connect
3	NC	No Connect
4	GND	Circuit & Package Ground
5	Output	RF Output [Note 2]
6	NC or EOH	No Connect or Optional Enable
7	NC	No Connect
8	V _{CC}	Supply Voltage

Pin Assignments – 4-Pad Solder Attach

Pin	Symbol	Function
1	V _C	GND or NC – TCXO [Note 1] Control Voltage – VCTCXO
2	GND	Circuit & Package Ground
3	Output	RF Output [Note 2]
4	V _{CC}	Supply Voltage

Notes

1. Connect to ground for TCXO, no frequency tuning. Pin can be left floating.
2. DC-Cut capacitor required. Add 1000pF capacitor between TCXO output and input of load.

Table I - Date Code, Beginning year 2021

					MONTH											
					JAN	FEB	MAR	APR	MAY	JUN	JUL	AUG	SEP	OCT	NOV	DEC
YEAR																
2021	2025	2029	2033	2037	A	B	C	D	E	F	G	H	J	K	L	M
2022	2026	2030	2034	2038	N	P	Q	R	S	T	U	V	W	X	Y	Z
2023	2027	2031	2035	2039	a	b	c	d	e	f	g	h	j	k	l	m
2024	2028	2032	2036	2040	n	p	q	r	s	t	u	v	w	x	y	z

Packaging - Tape and Reel

Tape Drawing

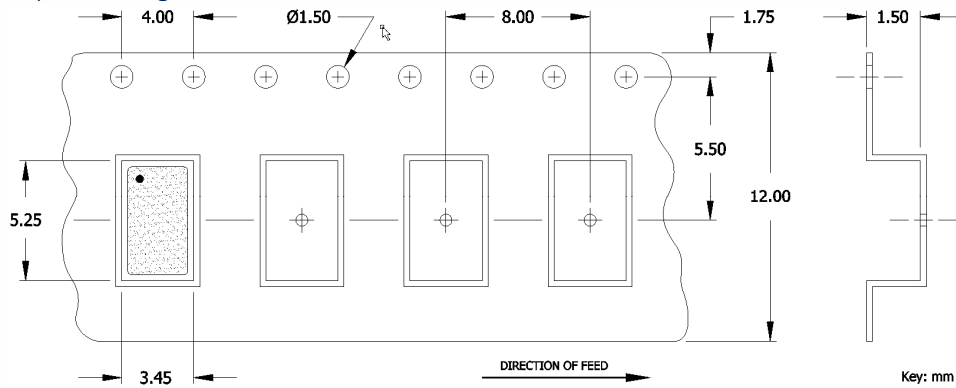

Reel Drawing

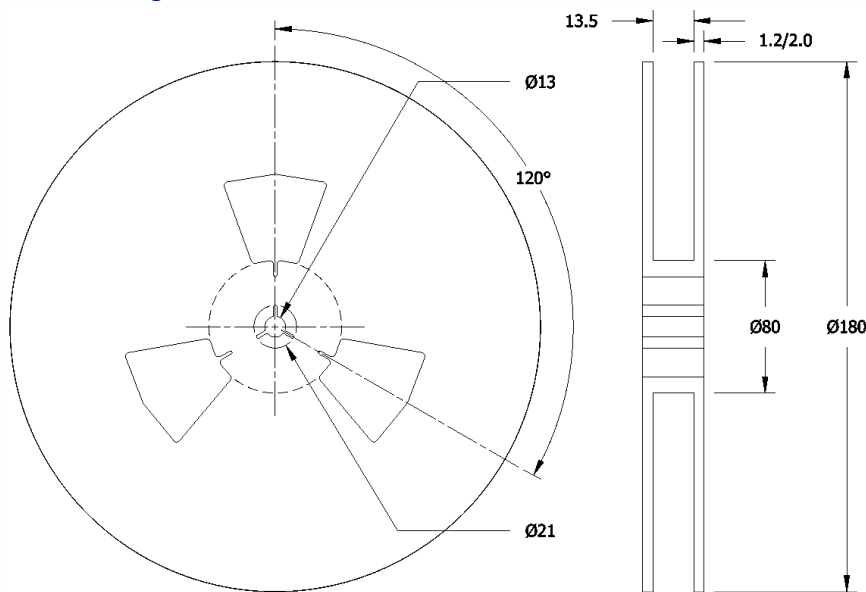

Notes

1. Device quantity is 1k pieces per 180mm reel.
2. Complete CTS part number, frequency value and date code information must appear on reel and carton labels.



Addendum

Common Frequencies and Frequency Codes – MHz

FREQUENCY	ORDERING CODE	FREQUENCY	ORDERING CODE	FREQUENCY	ORDERING CODE
10.000000	100	25.000000	250	50.000000	500
12.800000	128	26.000000	260	52.000000	520
13.000000	130	27.000000	270		
16.000000	160	30.000000	300		
16.384000	163	30.720000	307		
16.800000	168	32.000000	320		
19.200000	192	36.000000	360		
19.440000	194	38.400000	384		
20.000000	200	38.880000	388		
20.480000	204	40.000000	400		
24.000000	240	48.000000	480		
24.576000	24C	49.152000	491		

Frequencies in **bold** are standard.