



soberton inc.

SP DYNAMIC SPEAKER UNIT

Acoustic Product Specification

Product Number: SP-7140-2



Release | Revision: C/2017

CONTENTS

This document contains the technical specifications for the dynamic speaker unit.

Page 1

Speaker Electroacoustic Characteristics

General Specifications

Page 2

Reliability Tests

Page 3

Measuring Method (Speaker Mode)

Block Diagram for Measurement Method

Page 4

Frequency Response Curve

Page 5

Dimensions

Page 6

Packing

Dynamic Speaker Electroacoustic Characteristics

Sound Pressure Level

85±3dB (0.1W/0.1M) @AVE 0.5KHz,1.0KHz,1.5KHz, 2.0KHz
Measuring conditions and procedures shown in Fig 1 & Fig 2

Frequency Response Curve

As shown in Figure 3

Resonance Frequency

300±20% Hz

Input Power (Nominal and Maximum)

Rated Noise Power: 3.0W

Short Term Max Power: 5.0W

Frequency Range

F0 ~ 20KHz

Buzz, Rattle, Etc

Not audible from F0 to 20KHz with 4.89V sine wave input

Polarity

When positive voltage is applied to the terminal marked (+), diaphragm should be moved to the front.

Magnet

Rare earth permanent (NdFeB) magnet φ12.5x3mm

AC Impedance

8Ω ±15%

Distortion

Less Than 5% @1KHz Input Rated Power

Dimension

71.0 x40.0x23.0mm

General Specifications

Operating Temperature Range

-20°C~+65°C

Storage Temperature Range

-30°C ~ +80°C

Standard Test Conditions

Temperature 5°C~35°C

Relative Humidity 45%~85%(RH)

Air Pressure 860 mbar ~ 1060 mbar

IP Level

No rating



soberton inc.

SP DYNAMIC SPEAKER UNIT

Acoustic Product Specification

Product Number: SP-7140-2



Release | Revision: C/2017

CONTENTS

This document contains the technical specifications for the dynamic speaker unit.

Page 1
Speaker Electroacoustic Characteristics

General Specifications

Page 2
Reliability Tests

Page 3
Measuring Method (Speaker Mode)

Block Diagram for Measurement Method

Page 4
Frequency Response Curve

Page 5
Dimensions

Page 6
Packing

Reliability Tests

The sound pressure as specified will neither deviate more than $\pm 3\text{dB}$ from the initial value, nor have any significant damage after any of the following testing

High Temperature Test

High Temperature $+70\pm 3^\circ\text{C}$

Duration 96 hours (leave 6 hours in normal temperature and then check)

Low Temperature Test

Low Temperature $-30\pm 3^\circ\text{C}$

Duration 96 hours (leave 6 hours in normal temperature and then check)

Humidity Test

Temperature $+30\pm 3^\circ\text{C}$

Relative Humidity 92%~95%

Duration 96 hours (leave 3 hours in normal temperature and then check)

Vibration

10Hz ~ 55Hz ~ 10Hz sine wave sweep 15 minute 5G(constant)

X, Y, Z 3 directions, 2 hours each, total 6 hours

Temperature Cycle Test

The part will be subjected to 5 cycles. One cycle shall be 6 hours and consist of:

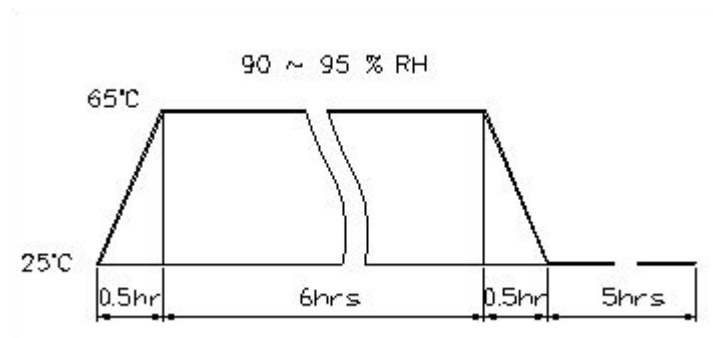

Drop Test

Drop the speakers contained in normal box onto the board 40mm thick 10 times from the height of 75cm

Load Test

Rate Power Pink noise is applied for 24 hours at room temp

Lead Wire Pull Strength

The pull force will be applied to double lead wire

Horizontal 3.0N(0.306kg) for 30 seconds

Vertical 2.0N(0.204kg) for 30 seconds



soberton inc.

SP DYNAMIC SPEAKER UNIT

Acoustic Product Specification

Product Number: SP-7140-2



Release | Revision: C/2017

CONTENTS

This document contains the technical specifications for the dynamic speaker unit.

Page 1

Speaker Electroacoustic Characteristics

General Specifications

Page 2

Reliability Tests

Page 3

Measuring Method (Speaker Mode)

Block Diagram for Measurement Method

Page 4

Frequency Response Curve

Page 5

Dimensions

Page 6

Packing

Measuring Method (Speaker Mode) (Fig. 1)

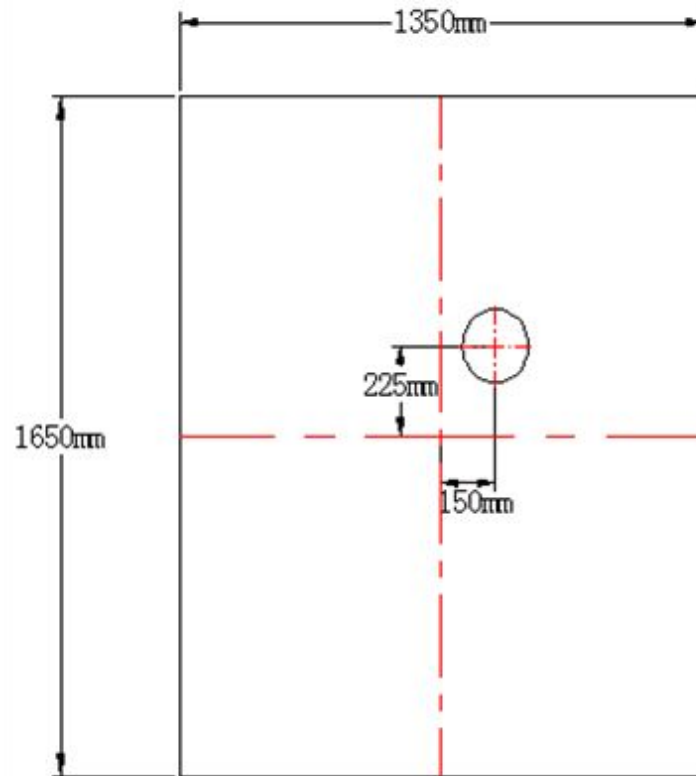

Block Diagram for Measurement Method (Fig. 2)

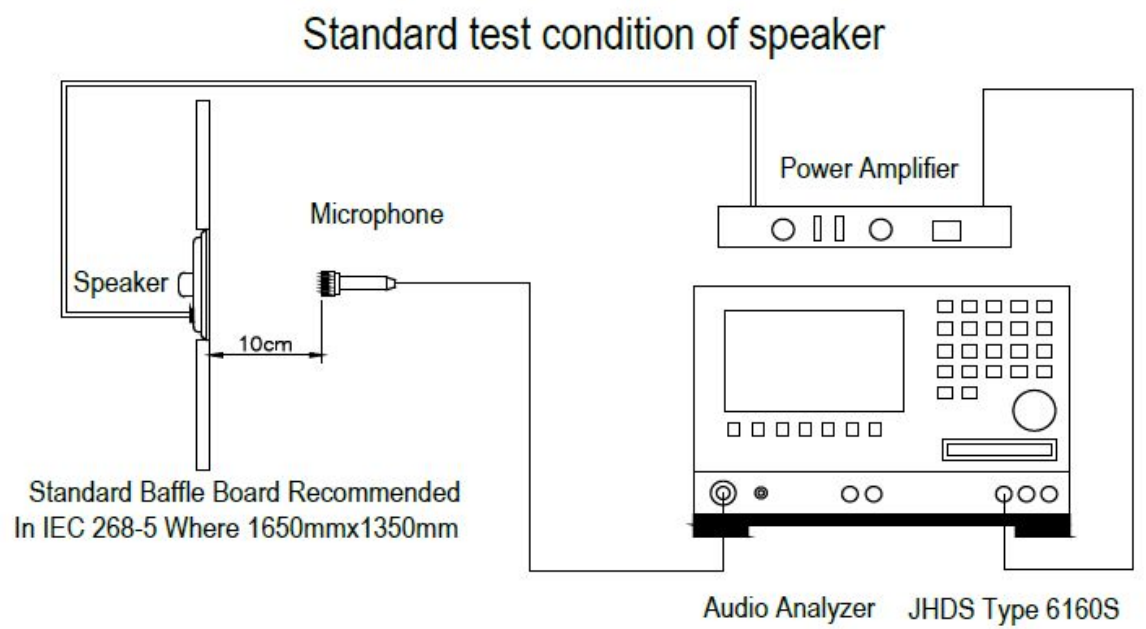



soberton inc.

SP DYNAMIC SPEAKER UNIT

Acoustic Product Specification

Product Number: SP-7140-2



Release | Revision: C/2017

CONTENTS

This document contains the technical specifications for the dynamic speaker unit.

Page 1

Speaker Electroacoustic Characteristics

General Specifications

Page 2

Reliability Tests

Page 3

Measuring Method (Speaker Mode)

Block Diagram for Measurement Method

Page 4

Frequency Response Curve

Page 5

Dimensions

Page 6

Packing

Frequency Response Curve (Fig. 3)

The swept sine-wave frequency response of a loudspeaker should ideally not deviate more than indicated.





soberton inc.

SP DYNAMIC SPEAKER UNIT

Acoustic Product Specification

Product Number: SP-7140-2



Release | Revision: C/2017

CONTENTS

This document contains the technical specifications for the dynamic speaker unit.

Page 1

Speaker Electroacoustic Characteristics

General Specifications

Page 2

Reliability Tests

Page 3

Measuring Method (Speaker Mode)

Block Diagram for Measurement Method

Page 4

Frequency Response Curve

Page 5

Dimensions

Page 6

Packing

Dimensions

Tolerance: ± 0.5 (unit: mm)

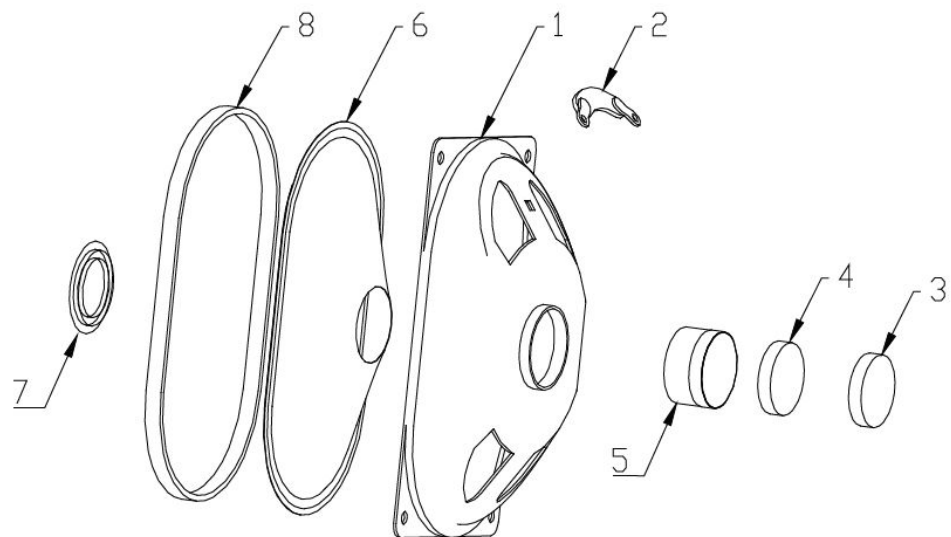
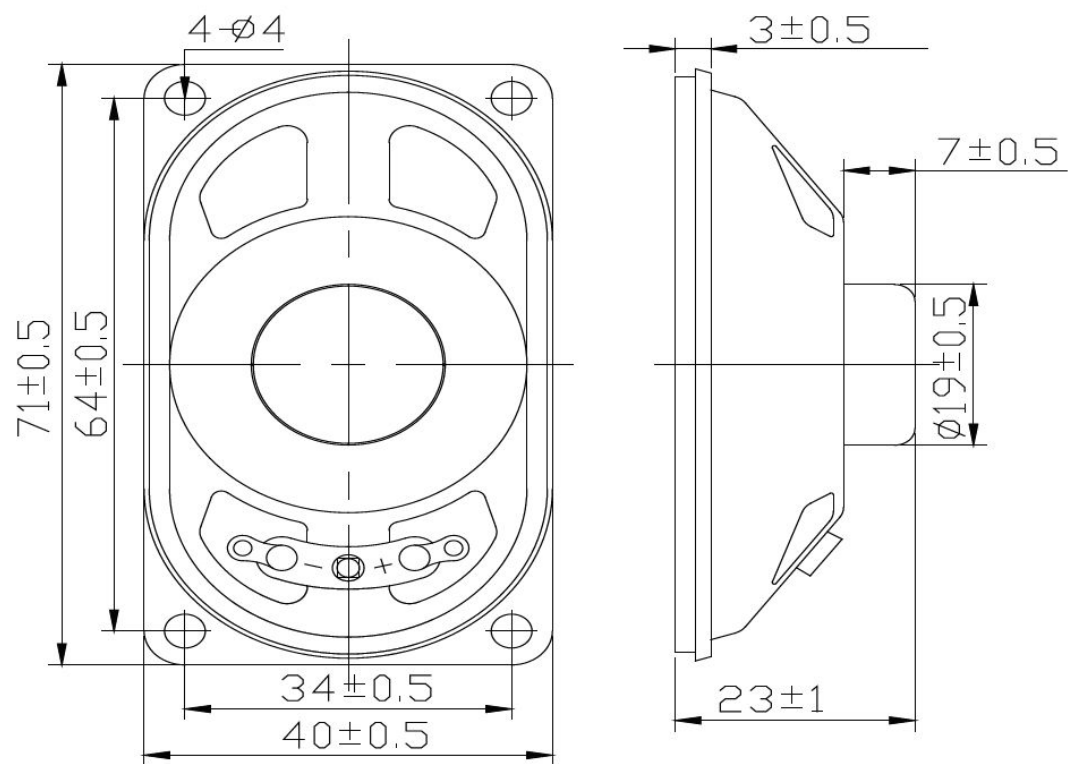

No.	Part Name	Material	Quantity
1	Frame	Metal	1
2	PCB Terminal	Paper + metal	1
3	Magnet	NdFeB	1
4	Plate	SPCC	1
5	Voice Coil	Paper + Cu	1
6	Diaphragm	Cloth + paper	1
7	Cap	Paper	1
8	Gasket	Paper	1



soberton inc.

SP DYNAMIC SPEAKER UNIT

Acoustic Product Specification

Product Number: SP-7140-2



Release | Revision: C/2017

CONTENTS

This document contains the technical specifications for the dynamic speaker unit.

Page 1

Speaker Electroacoustic Characteristics

General Specifications

Page 2

Reliability Tests

Page 3

Measuring Method (Speaker Mode)

Block Diagram for Measurement Method

Page 4

Frequency Response Curve

Page 5

Dimensions

Page 6

Packing

Packing

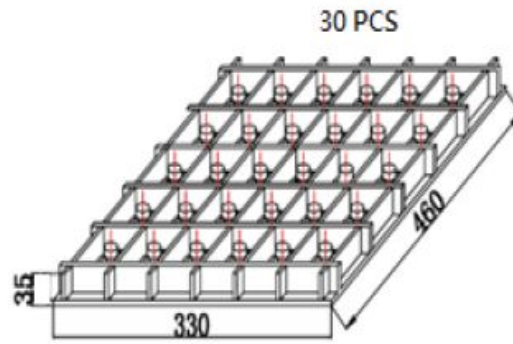

300PCS/Carton
Net Weight: 9Kg
Gross Weight: 11Kg

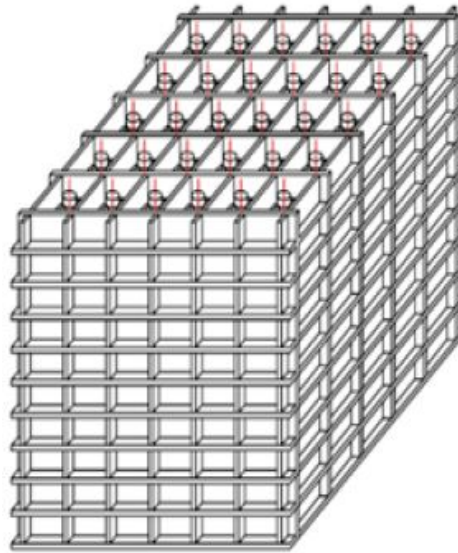

30PCS x 10=300PCS

