



Using the BCIM Controller with Powerex IPMs

Introduction:

The BCIM board features a three phase AC motor controller IC at its core. The board is designed to provide an interface between the controller and Powerex IPM design kits. The BCIM board provides PWM signals for the IGBTs in the three legs of a 3 phase inverter plus a brake signal.

Using this board along with Powerex IPM design kits allows designers to be able to quickly verify their Power circuit layout and also gives them an opportunity to see a working control circuit layout.

The information in this document pertains only to the board and its external connections. For information specific to the controller please contact Freescale Semiconductor.

Building the BCIM board:

The BCIM kit comes as a bare board along with all of the parts listed in the bill of materials. The PCB is a two layer board and all of the components are through hole. You will need to refer to Figure 4 shown at the end of this document which shows the complete component layout in order to complete the board.

BCIM Connections:

The BCIM controller board has three connectors, CN1, CN2 and CN3. CN2 is a 2-pin connector that brings in an 8-24V DC power supply and converts it to a regulated 5V supply for the control logic. CN1 is a 10-pin connector for bringing out the 5V logic power supply and all of the control signals for the high and low sides of a three phase inverter plus brake. The 10-pin connector is also used for bringing the fault feedback to the controller. CN3 is connector that brings in a divided DC bus voltage for feedback into the MC3PHAC MCU.

BCIM Power Requirements:

The BCIM will use a maximum of 200mA from the 5VDC supply for a total of 1W needed at the output of the 5V regulator. In addition the 5V regulator will have a voltage drop of anywhere between 3V (8V-5V) and 19V (24V-5V) which will mean an additional 0.6W to 3.8W of power loss.

Connecting the BCIM to L-series IPM development kits:

The 10-pin connector on the BCIM is made to connect directly to the 10-pin connectors used in the BP6A and BP7A L-series IPM development kits through 10 conductors. Again, this will

provide the proper interface between the controller and IPM for all of the control signals including the brake, the 5V logic power supply and the fault feedback from the IPM to the MCU.

The 24V or 15V control power that is needed for the IPM development boards can be shared with the BCIM board or separate power supplies can be used.

Figure 1 shows how the connection is made from the BCIM to the BP6A/BP7A.

Figure 1. BCIM to BP7A/BP6A

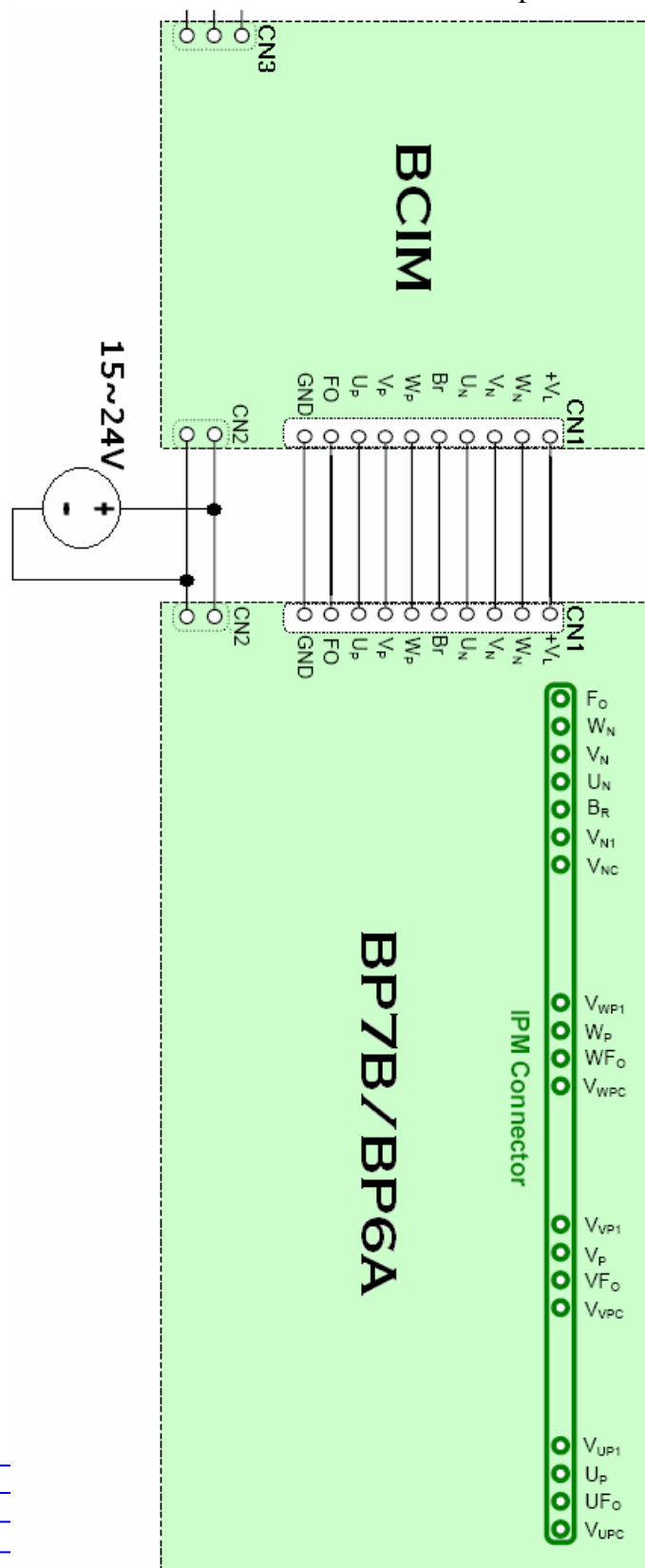

Connecting the BCIM to Super Mini DIP-IPM and Mini DIP-IPM Demonstration Boards:

The BCIM can also be connected to the Super Mini DIP-IPM and Mini DIP-IPM demonstration boards (DK-PS21562/3/4 and DK-PS21962/3/4) in much the same way that it connects to the BP6A and BP7A boards. The input connectors for these kits do differ in a few ways and so the connection will be somewhat different. The main differences are that there is no brake pin for the Mini/Super Mini demo boards and the +15V supply is part of the 10 pin connector as opposed to having its own separate connector. Another difference in the connectors is that the input control signal pins (Up, Un, Vp, Vn, etc.) are in a different order so the connection wires between the BCIM and the development board will need to be permuted.

An illustration of how to connect the BCIM board to the Mini/Super Mini Demo boards is shown in Figure 2.

Setting the 6-Position DIP-Switch:

The first four of the six switch positions of the IPM are as follows:

- Position 1: 60Hz+
- Position 2: 60Hz-
- Position 3: 50Hz+
- Position 4: 50Hz-

The four switch positions are designed to allow the user to control either a 50Hz or 60Hz motor using either active high or

Figure 2: BCIM to DK-PS21XXX

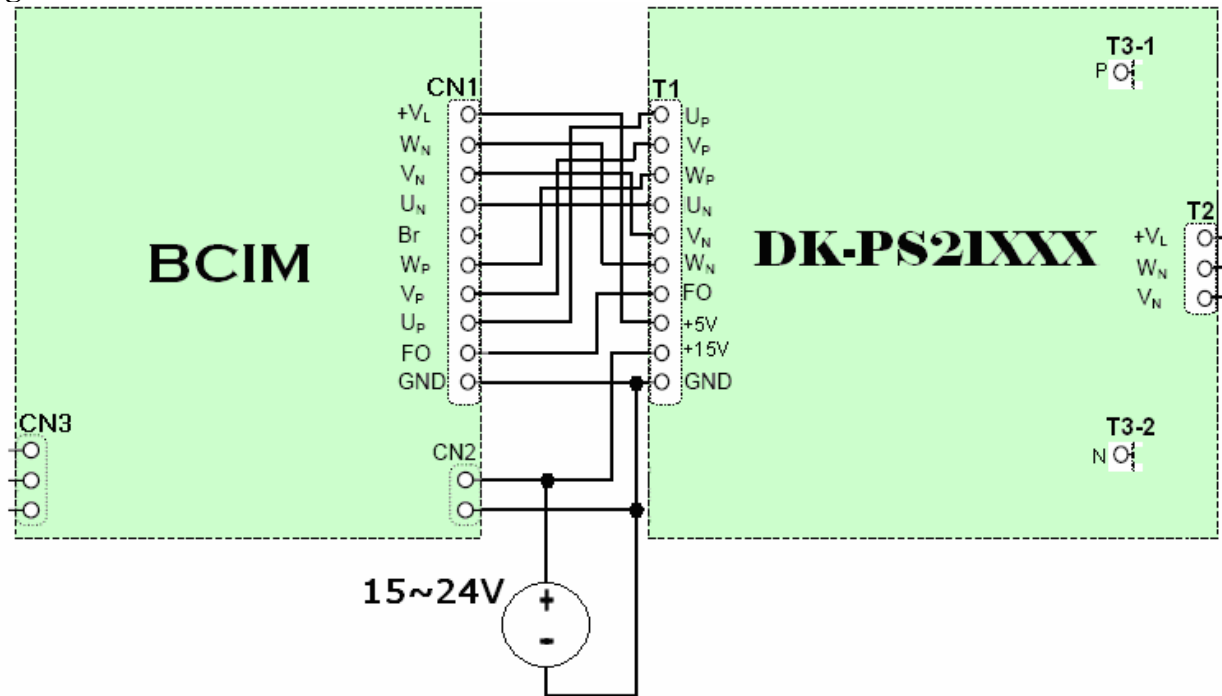

active low control logic.

It is important that only one of the first four positions is in the ON state at any time to prevent erroneous operation.

The L-series IPM development boards are designed to bring active low logic to the IPMs control pins and require either position 2 or position 4 to be ON where position 2 is used for a 60Hz motor and position 4 is for a 50Hz motor.

The development kits for the DIP-IPM modules are designed for bringing active high logic to the control pins and therefore either position 1 or position 3 should be ON. In this case position 1 is for a 60Hz motor while position 3 is used for 50Hz motors.

Positions 5 and 6 are the start/stop and forward/reverse positions. Changing position 5 to ON or OFF will start or stop the motor respectively. Position 6 works in the same manner where ON is reverse and OFF is forward.

Speed and Acceleration Control:

P1 and P2 marked speed and acceleration on the board are rotated clockwise to increase their value or rotated counterclockwise to decrease their value.

The speed control changes the motor current waveform frequency from 1 to 128 Hz and the acceleration rate can be adjusted to a value between 0.5 and 128 Hz/s.

BCIM Feedback Controls:

The BCIM has two feedback controls: the fault signal feedback and the bus voltage level feedback.

The fault feedback is set up on the board to be active low. If low level logic comes back to the BCIM board because one of the IPMs protection functions have been activated the PWM signals from the controller will be immediately disabled. Once the fault clears and a high logic signal is being fed back to the board the motor controller starts a fault retry timer and the PWM signals are re-enabled after the duration of the programmed timeout value.

The bus voltage feedback control is monitored from pin 2 to pin 3 of CN3. The nominal voltage feedback level is 3.5V. The voltage level required to assert the brake signal is 3.85V. Any voltage reading outside of 1.75V minimum and 4.47V maximum constitutes a fault condition and the PWM signals are disabled. Once the voltage returns to an acceptable value the fault retry timer starts and PWM is re-enabled once the programmed timeout value is reached.

The board also employs deceleration control via the MC3PHAC and the voltage feedback input on the board. The acceleration value set by P2 is also used to set the deceleration value and is equivalent in magnitude. However, when the voltage exceeds 3.85V, the deceleration rate is moderated to control the bus voltage. If bus voltage monitoring is not desired it must be disabled by placing a jumper wire between pins 2 and 3.

Figure 3. BCIM Circuit Schematic

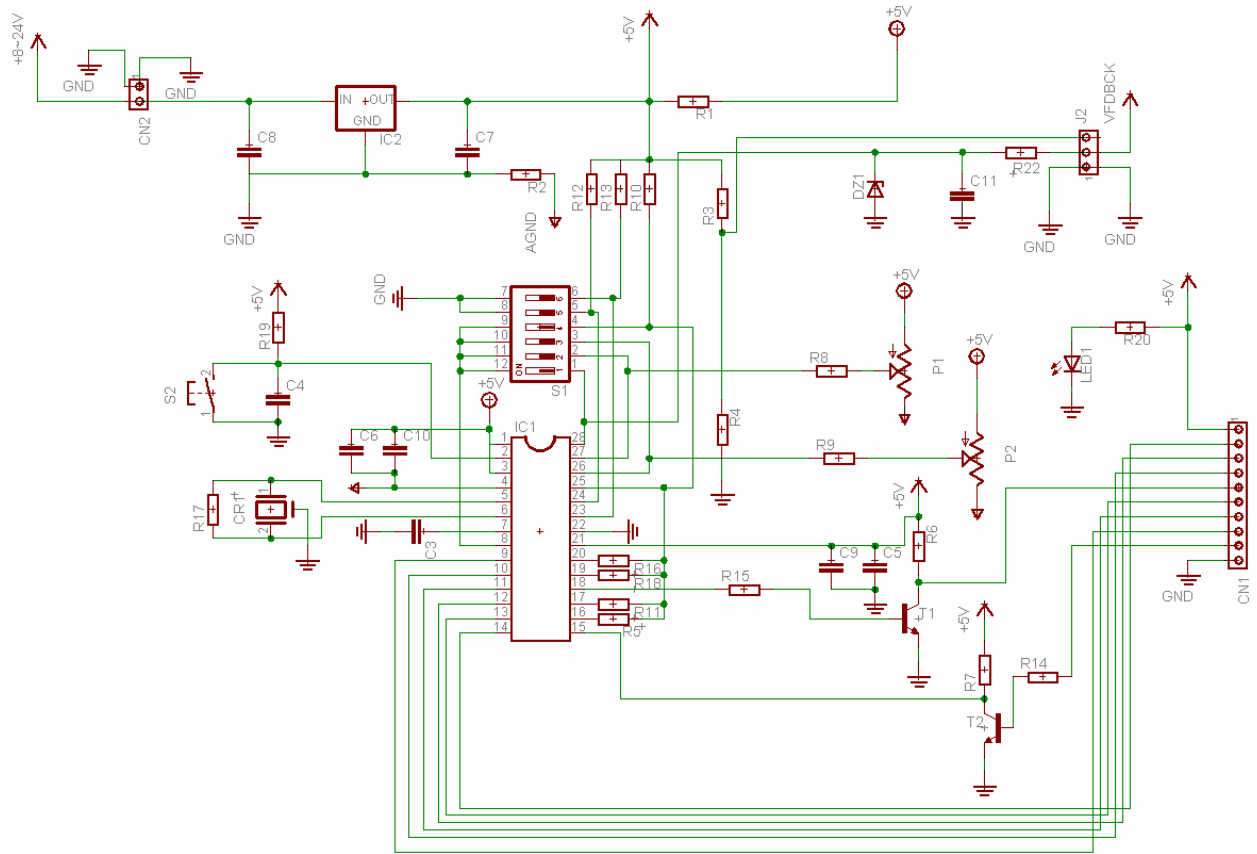

Figure 4. Component Layout:

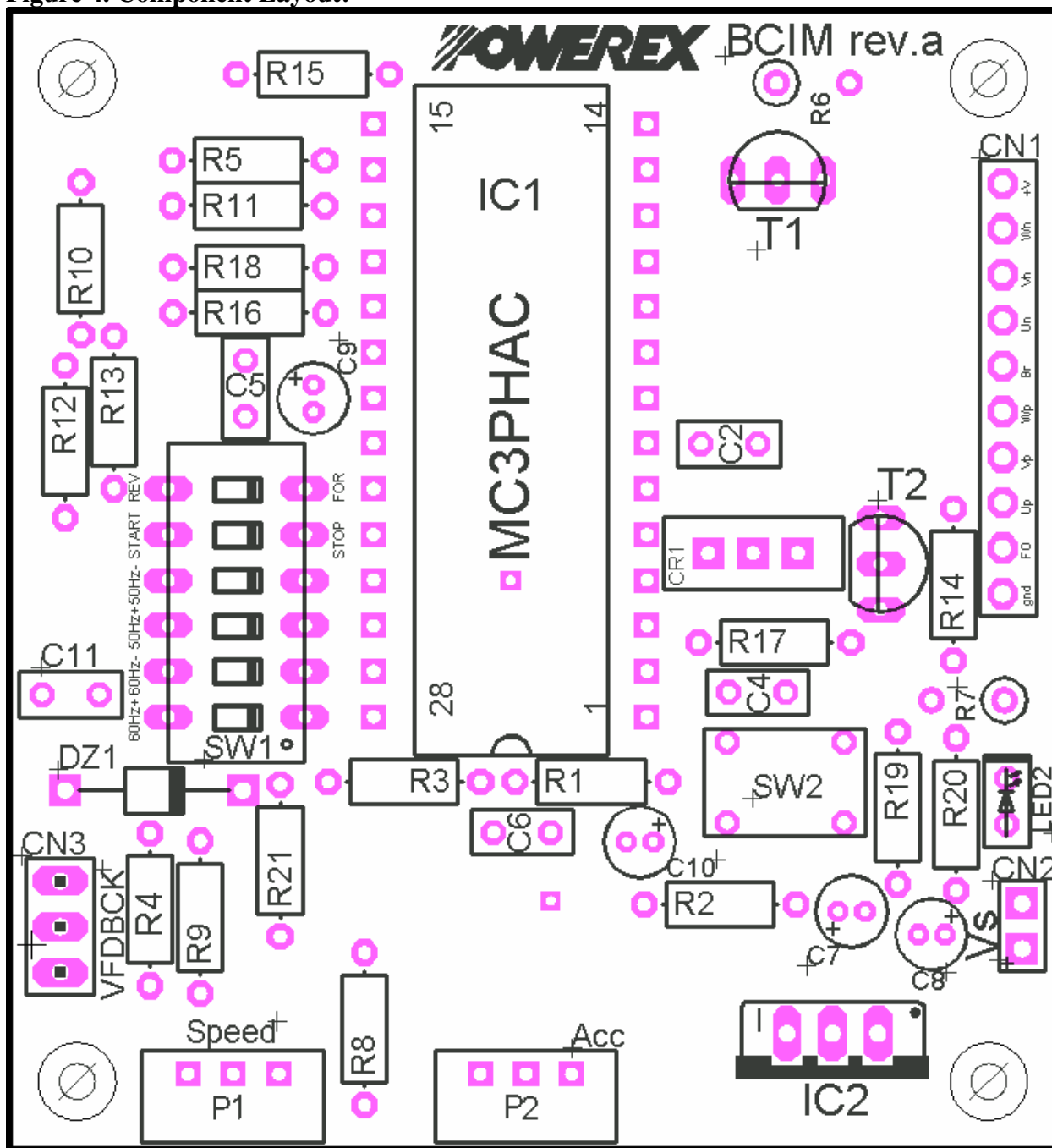

Table 1. Bill of Materials:

Item	Description	Manufacturer	Man PN	Digikey PN
C2, C4, C5, C6	CAP 50V .1UF RADIAL CERAMIC X7R	BC Components	A104K15X7RF5TAA	BC1084CT-ND
C7, C8, C9, C10	CAP 10UF 50V ELECT FC RADIAL	Panasonic	EEU-FC1H100	P11250-ND
C11	CAP 4700PF 100V CERAMIC MONO 10%	EPCOS, Inc.	B37981M1472K054	495-1053-1-ND
DZ1	Diode Zener 5.1V 0.5W	Diodes Inc.	1N5231B-T	1N5231BDICT-ND
LED1	LED 3MM 565NM GREEN TINT	Avago Technologies	HLMP-1521	516-1298-ND
CR1	CERAMIC RESONATOR 4.0 MHZ	Panasonic	ZTT-4.00MG	X902-ND
R1, R2	Resistor, 1 Ω , 1/4 W	-	-	-
R3, R20	Resistor, 1.5k Ω , 1/4 W	-	-	-
R4, R21	Resistor, 3.6k Ω , 1/4 W	-	-	-
R5	Resistor, 3.9k Ω , 1/4 W	-	-	-
R6, R7, R8, R9	Resistor, 4.7k Ω , 1/4 W	-	-	-
R10	Resistor, 6.8k Ω , 1/4 W	-	-	-
R11	Resistor, 8.2k Ω , 1/4 W	-	-	-
R12, R13, R14, R15, R19	Resistor, 10k Ω , 1/4 W	-	-	-
R16	Resistor, 12k Ω , 1/4 W	-	-	-
R17	Resistor, 1M Ω , 1/4 W	-	-	-
R18	Resistor, 5.1k Ω , 1/4 W	-	-	-
CN1	10 pos. 0.1" right angle single row header	Tyco Electronics/Amp	1-640457-0	A1930-ND
CN2	2 pos. 0.1" right angle single row header	Tyco Electronics/Amp	640457-2	A1926-ND
CN3	3 pos. 0.1" right angle single row header	Tyco Electronics/Amp	640457-3	A19480-ND
IC1	AC MOTOR CONTROLLER 28-DIP	Freescale	MC3PHACVPE	MC3PHACVPE-ND
IC2	REG 5 VOLT 1A TO220	ON Semiconductor	MC7805CTG	MC7805CTGOS-ND
T1, T2	TRANS NPN SW HS 200MA 40V TO92	Philips	2N3904	568-1366-1-ND
P1, P2	POT 5K OHM 9MM SQ RTANG PLAST	Bourns	3310C-001-502	3310C-001-502-ND
SW1	SWITCH 6 POS DIP EXTENDED UNSLD	Grayhill	78B06	GH1237-ND
SW2	SWITCH TACT 6MM 260GF H=4.3MM	Omron	B3F-1005	SW793-ND

Table 2 lists additional application notes for development boards designed for use with the BCIM. Clicking on the application note name will bring up the associated pdf document. The linked application notes provide additional specifications and application circuit examples as well as information about associated accessory products.

Table 2. Additional Reading

Application Note	Product Type	IPM Module Application
BP7A	6/7 Channel L-Series IPM Development Board	600V Module 50 to 300A 1200V Module 25 to 150A
BP6A	6 Channel L-Series IPM Development Board	600V Module 450 to 600A 1200V Module 200 to 450A
DK-PS2156X	Mini DIP-IPM Development Board	600V Module 20A to 30A
DK-PS2196X	Super Mini DIP-IPM Development Board	600V Module 5 to 20A
