

** Not all features are shown in this drawing. For more detailed information, please contact your Fair-Rite representative.

SIZE	PART NO.	REV.
B	9579200602	~

UNCONTROLLED ~CATALOG~ DRAWING

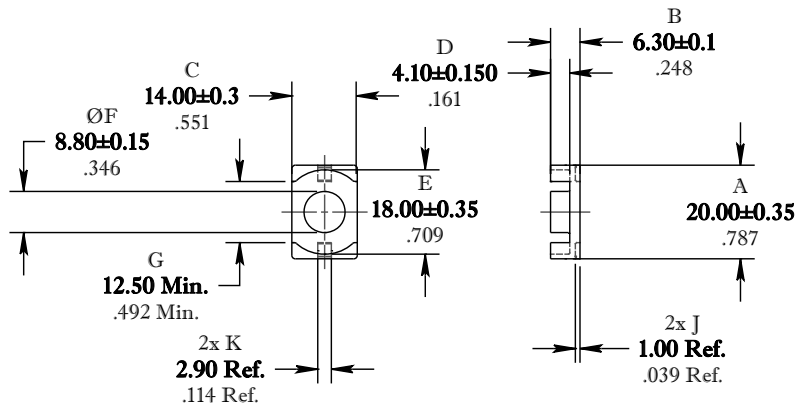

DIMENSIONS
BOLD NUMBERS ARE IN MILLIMETERS
 LIGHT NUMBERS ARE IN INCHES

ELECTRICAL SPECIFICATIONS

$\Sigma l/A(mm^{-1})$	$l_e (mm)$	$A_e (mm^2)$	$A_{Min} (mm^2)$	$V_e (mm^3)$	$A_L (nH)$ @ 10 kHz <10gauss	$\tan \delta/\mu_i$ @ 500 kHz <1gauss
0.553	33.3	60.0	55.0	2000	2440±25%	$\leq 15 \times 10^{-6}$

MATE PAIR: CLAMPING FORCE = 5 lbs.

POWER LOSS @ 100°C
 $f = 500 \text{ kHz}, 500g \text{ P.L. } < 0.26 \text{ Watts}$

FAIR-RITE PRODUCTS CORP.						
TITLE "EQ" CORE						
DRAWN BY D. FOOTE	DATE 3-19-2019	SIZE	PART NO.		REV.	
CHKD BY		B	9579200602		~	
APPRVD BY		SCALE	NONE	SHEET	1 of 1	

FR# 79