

Tous droits strictement reserves. Reproduction ou communication a des tiers interdite sous quelque forme que ce soit sans autorisation écrite du propriétaire. Propriete de c FCI. Droits de reproduction FCI.

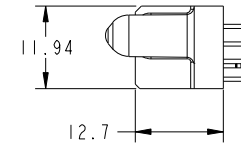

All rights strictly reserved. Reproduction or issue to third parties in any form whatever is not permitted without written authority from the proprietor. Property of FCI. Copyright FCI.

PRODUCT NO.	ROWS	SIGNAL					POWER							E1				
		E2	6	5	4	3	2	1	P7	P6	P5	P4	P3		P2	P1		
51940-329-- NOTE: 3	D C B A		E	E	E	E	E	E	E	E	E	E	E	E	E	E	E	

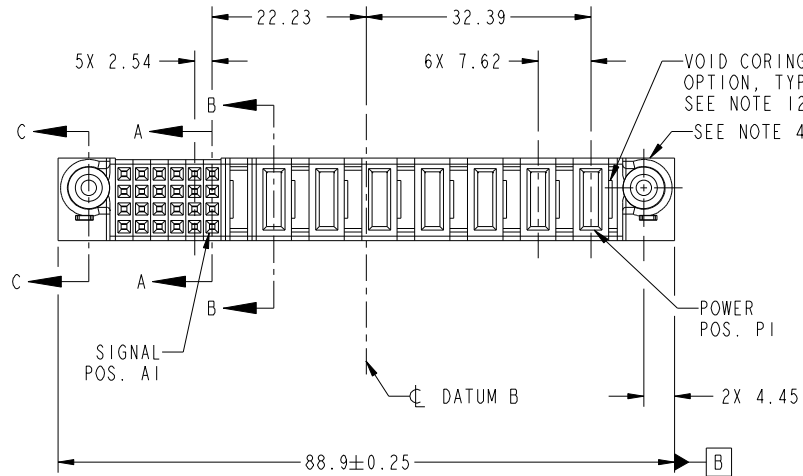

CODE	DIM "M" MATING LENGTH	CONTACT TYPE
E	[N/A]	SIGNAL
PD	[2.34]	POWER
HA	[N/A]	HOLD-DOWN
PA	[1.07]	POWER

mat'l code				SEE NOTES		tolerances unless otherwise specified		CUSTOMER		FCI	
ltr	ecn no.	dr	date	linear	0.X ±0.5	COPY		www.fciconnect.com		title	
A	DG10-0027	WD	01/15/10	angles	0.XX ±0.25	projection		7ACP + 24S		VERTICAL SOLDER RECEPT	
				dr	0.XXX ±0.1	MIM		product family		PwrBlade	code
				enr	0° ±2°	scale		size		A	213
				chr		1:1		dwg no		51940-329	
				appd				sheet		1 of 4	
sheet index	revision sheet	A	A	A	A			cage code		22526	
1	2	3	4							4	

Pro/E

cage code 22526

Tous droits strictement reserves. Reproduction ou communication a des tiers interdite sous quelque forme que ce soit sans autorisation écrite du propriétaire. Propriete de c FCI. Droits de reproduction FCI.



All rights strictly reserved. Reproduction or issue to third parties in any form whatever is not permitted without written authority from the proprietor. Property of FCI. Copyright FCI.

PRODUCT NUMBER
51940-329__
NOTE: 3

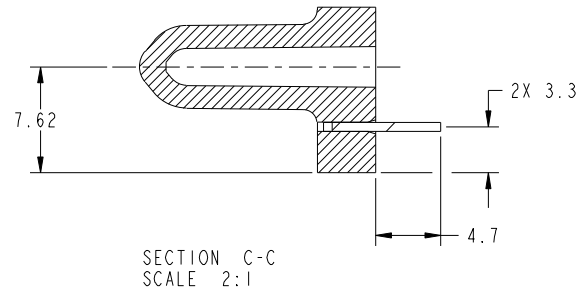
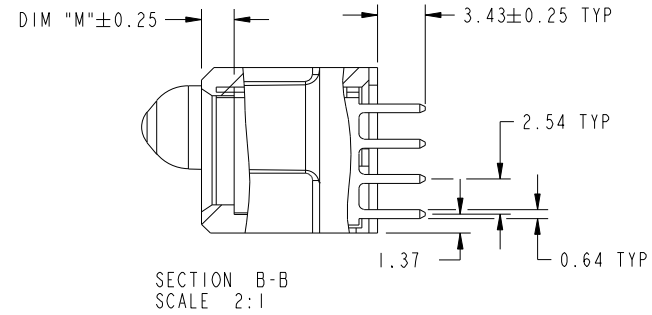
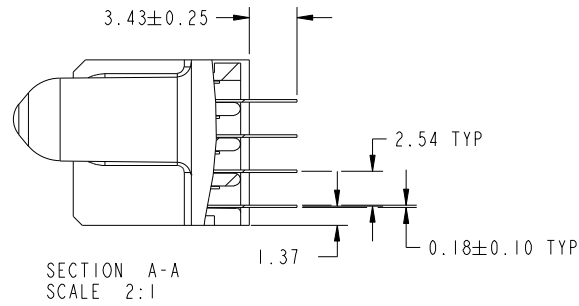

mat'l code				tolerances unless otherwise specified		CUSTOMER		www.fciconnect.com					
ltr	ecn no.	dr	date	linear	0.X ±0.5	COPY			title 7ACP + 24S VERTICAL SOLDER RECEPT				
A					0.XX ±0.25					product family	PwrBlade	code	213
					angles	0.XXX ±0.1				size	dwg no	sheet	2 of 4
				dr	0° ±2°	scale 1:1		A	51940-329				
				enr	Warren Du 12/23/09								
				chr	Warren Du 12/23/09								
				appd	PM ZHENG 12/23/09								
				appd	Joseph Hsia 12/23/09								
sheet index	revision sheet												

cage code 22526

Pro/E

Tous droits strictement reserves. Reproduction ou communication a des tiers interdite sous quelque forme que ce soit sans autorisation écrite du propriétaire. Propriete de c FCI. Droits de reproduction FCI.

All rights strictly reserved. Reproduction or issue to third parties in any form whatever is not permitted without written authority from the proprietor. Property of FCI. Copyright FCI.



PRODUCT NUMBER
51940-329__
NOTE: 3

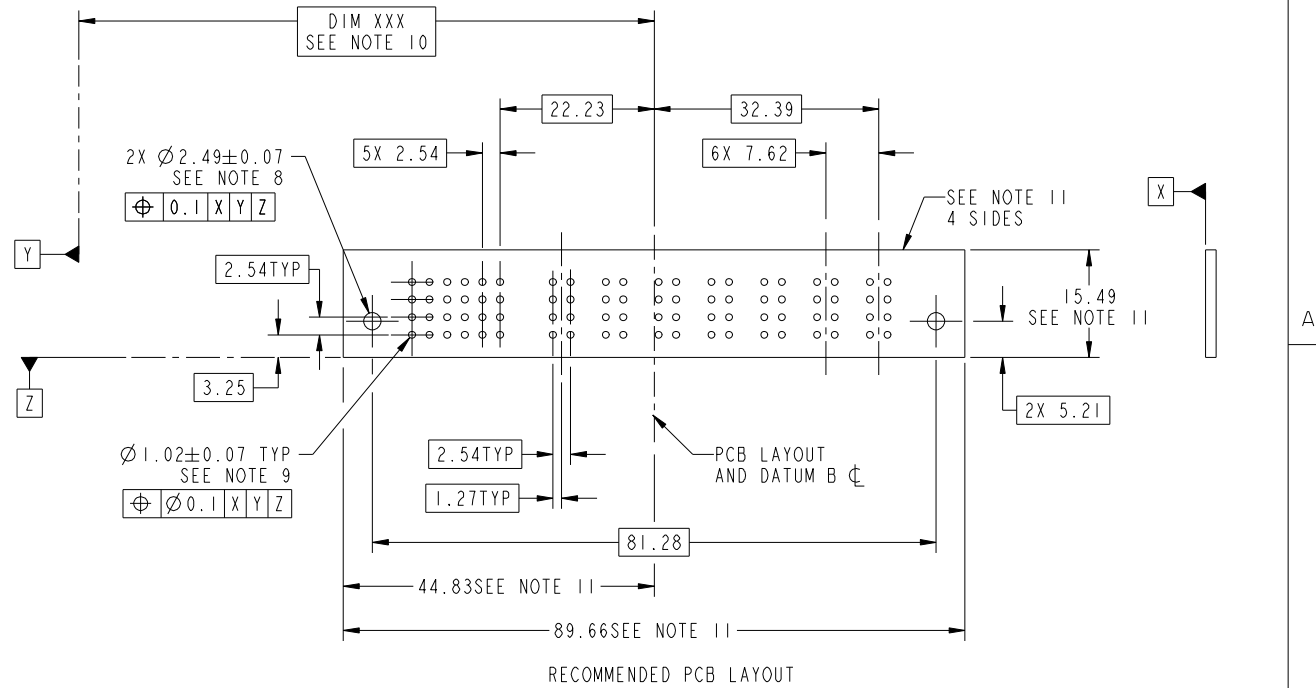

mat'l code				tolerances unless otherwise specified		CUSTOMER		FCI	
ltr	ecn no.	dr	date	linear	0.X ±0.5	COPY		www.fciconnect.com	
A					0.XX ±0.25	projection		title	
				angles	0.XXX ±0.1			7ACP + 24S VERTICAL SOLDER RECEPT	
				dr	0° ±2°			product family PwrBlade code 213	
				enrg	Warren Du 12/23/09	scale		size dwg no 213	
				chr	Warren Du 12/23/09	1:1		sheet 3 of 4	
				appd	PM ZHENG 12/23/09			51940-329	
					Joseph Hsia 12/23/09				
sheet index		revision sheet							

cage code 22526

Pro/E

Tous droits strictement reserves. Reproduction ou communication a des tiers interdite sous quelque forme que ce soit sans autorisation écrite du propriétaire. Propriete de c FCI. Droits de reproduction FCI.



All rights strictly reserved. Reproduction or issue to third parties in any form whatever is not permitted without written authority from the proprietor. Property of FCI. Copyright FCI.

PRODUCT NUMBER
51940-329_-
NOTE: 3

NOTES:

1. DIMENSIONS AND TOLERANCES ARE IN ACCORDANCE WITH ASME Y14.5M, 1994 UNLESS OTHERWISE SPECIFIED.

CONNECTOR NOTES:

- 2 HOUSING MATERIAL: UL 94 V-0 GLASS FILLED HIGH-TEMP THERMOPLASTIC
POWER CONTACT MATERIAL: COPPER ALLOY
SIGNAL PIN MATERIAL: COPPER ALLOY
 - 3. SEE ITEM 1 & 2 IN PRINT 10064183 FOR PLATING SPEC OF 51940-329 AND 51940-329LF RESPECTIVELY.
 - 4 MANUFACTURER'S NAME, DATE CODE AND OPTIONAL P/N TO APPEAR ON THIS SURFACE. THE P/N CAN BE OMITTED IF THERE IS NOT ENOUGH SPACE ON THIS SURFACE.
 - 5. PRODUCT SPECIFICATION GS-12-149.
APPLICATION SPECIFICATION BUS-20-067.
 - 6. PACKAGED IN TRAYS.
- PCB NOTES:
- 7. ALL HOLE DIAMETERS ARE FINISHED HOLE SIZE.
 - 8 MOUNTING HOLES, WHERE APPLICABLE, ARE UNPLATED.
 - 9 $\varnothing 1.151 \pm 0.025$ DRILLED HOLES PLATED WITH
0.008 MIN SnPb OR Sn OVER 0.03
TO 0.08 Cu PLATING TO ACHIEVE
 $\varnothing 1.02 \pm 0.07$ HOLE.
 - 10 "DIM XXX" TO BE DETERMINED BY THE CUSTOMER.
 - 11 CONNECTOR KEEP-OUT ZONE.
 - 12. THE VOID CORING IN BETWEEN POWER MODULES, SIGNAL MODULES AND END MODULES ARE OPTIONAL AND THE SHAPE MAY BE DIFFERENT FOR OPTIMIZE THE MOLDING PROCESS. THE VOID CORING WILL NOT EFFECT TO PRODUCT FUNCTION.

mat'l code				tolerances unless otherwise specified		CUSTOMER		FCI	
ltr	ecr no.	dr	date	linear	0.X ± 0.5	COPY		www.fciconnect.com	
A				linear	0.XX ± 0.25	projection		title	
				angles	0.XXX ± 0.1			7ACP + 24S VERTICAL SOLDER RECEPT	
				dr	0° ± 2°	MIM		product family PwrBlade code	
				enrg	Warren Du 12/23/09			size 213	
				chr	Warren Du 12/23/09	scale		dwg no 4 of 4	
				appd	PM ZHENG 12/23/09	1:1		sheet	
					Joseph Hsia 12/23/09	A		51940-329	
sheet index	revision sheet								

cage code 22526

Pro/E