

Features

- Thin small outline package (TSOP I) configurable as 2 M × 16 or as 4 M × 8 static RAM (SRAM)
- Very high speed
 - 70 ns
- Wide voltage range
 - 1.65 V to 2.25 V
- Ultra low standby power
 - Typical standby current: 3 μA
 - Maximum standby current: 25 μA
- Ultra low active power
 - Typical active current: 4.5 mA at f = 1 MHz
- Easy memory expansion with \overline{CE}_1 , CE_2 , and \overline{OE} Features
- Automatic power-down when deselected
- Complementary metal oxide semiconductor (CMOS) for optimum speed and power
- Available in Pb-free 48-ball TSOP I and 48-ball FBGA package

Functional Description

The CY62177EV18 is a high-performance CMOS static RAM organized as 2 M words by 16 bits and 4 M words by 8 bits. This device features advanced circuit design to provide ultra low active current. It is ideal for providing More Battery Life™ (MoBL[®]) in portable applications, such as cellular telephones. The device also has an automatic power-down feature that significantly reduces power consumption by 99 percent when addresses are not toggling. The device can also be put into standby mode when deselected (\overline{CE}_1 HIGH or CE_2 LOW or both BHE and BLE are HIGH). The input and output pins (I/O₀ through I/O₁₅) are placed in a high impedance state when: deselected (\overline{CE}_1 HIGH or CE_2 LOW), outputs are disabled (\overline{OE} HIGH), both Byte High Enable and Byte Low Enable are disabled (BHE, BLE HIGH), or during a write operation (CE_1 LOW, CE_2 HIGH and WE LOW).

To write to the device, take Chip Enables (\overline{CE}_1 LOW and CE_2 HIGH) and Write Enable (WE) input LOW. If Byte Low Enable (BLE) is LOW, then data from I/O pins (I/O₀ through I/O₇), is written into the location specified on the address pins (A₀ through A₂₀). If Byte High Enable (BHE) is LOW, then data from I/O pins (I/O₈ through I/O₁₅) is written to the location specified on the address pins (A₀ through A₂₀). To read from the device, take Chip Enables (\overline{CE}_1 LOW and CE_2 HIGH) and Output Enable (OE) LOW while forcing the Write Enable (WE) HIGH. If Byte Low Enable (BLE) is LOW, then data from the memory location specified by the address pins appear on I/O₀ to I/O₇. If Byte High Enable (BHE) is LOW, then data from memory appears on I/O₈ to I/O₁₅. See the [Truth Table on page 11](#) for a complete description of read and write modes.

Pin #13 of the 48 TSOP I package is an DNU pin that must be left floating at all times to ensure proper application.

For a complete list of related documentation, [click here](#).

Logic Block Diagram

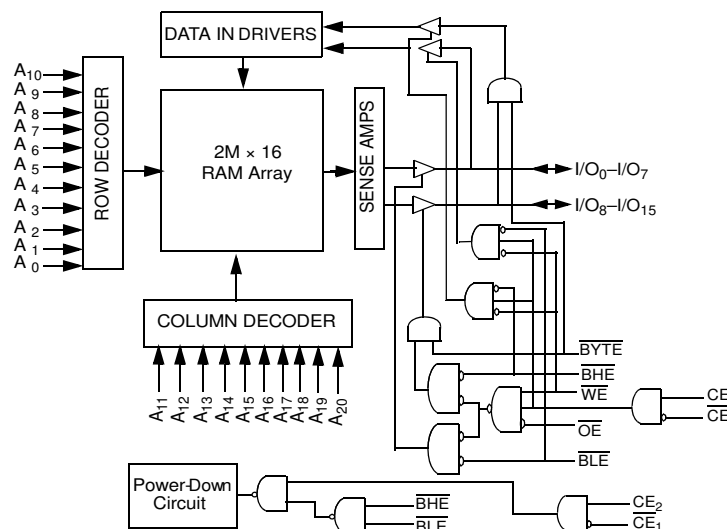

Contents

Pin Configuration	3	Ordering Information	12
Product Portfolio	3	Ordering Code Definitions	12
Maximum Ratings	4	Package Diagrams	13
Operating Range	4	Acronyms	15
Electrical Characteristics	4	Document Conventions	15
Capacitance	5	Units of Measure	15
Thermal Resistance	5	Document History Page	16
AC Test Loads and Waveforms	5	Sales, Solutions, and Legal Information	17
Data Retention Characteristics	6	Worldwide Sales and Design Support	17
Data Retention Waveform	6	Products	17
Switching Characteristics	7	PSoC [®] Solutions	17
Switching Waveforms	8	Cypress Developer Community	17
Truth Table	11	Technical Support	17

Pin Configuration

Figure 1. 48-pin TSOP I pinout (Front View) [1, 2]

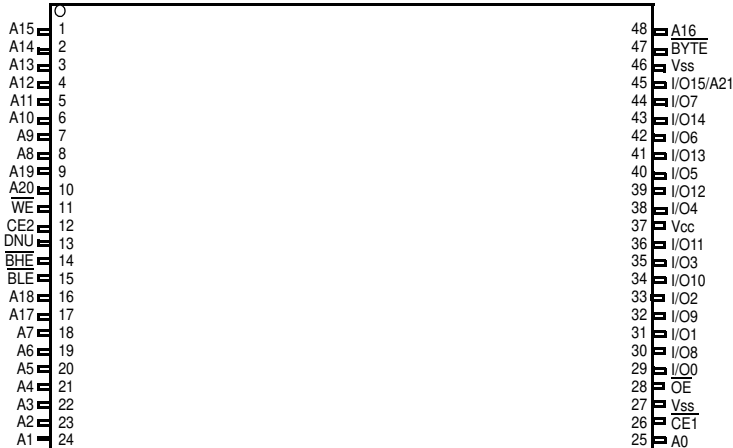
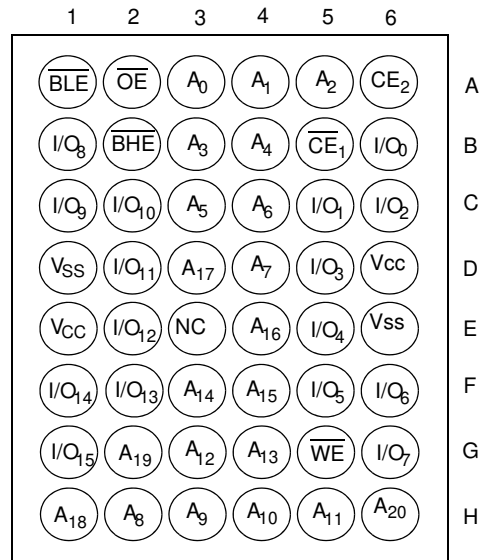

Figure 2. 48-ball FBGA pinout (Top View)



Product Portfolio

Product	V _{CC} Range (V)			Speed (ns)	Power Dissipation					
					Operating I _{CC} (mA)				Standby I _{SB2} (μA)	
	Min	Typ ^[3]	Max		f = 1 MHz		f = f _{Max}		Typ ^[3]	Max
					Typ ^[3]	Max	Typ ^[3]	Max		
CY62177EV18LL	1.65	1.8	2.25	70	4.5	5.5	35	45	3	25

Notes

1. DNU Pin# 13 needs to be left floating to ensure proper application.
2. The BYTE pin in the 48-TSOP I package has to be tied to V_{CC} to use the device as a 2 M_x16 SRAM. The 48-pin TSOP I package can also be used as a 4 M_x8 SRAM by tying the BYTE signal to V_{SS}. In the 4 M_x8 configuration, Pin 45 is A21, while BHE, BLE, and I/O₈ to I/O₁₄ pins are not used.
3. Typical values are included for reference only and are not guaranteed or tested. Typical values are measured at V_{CC} = V_{CC(typ)}, T_A = 25 °C.

Maximum Ratings

Exceeding maximum ratings may impair the useful life of the device. These user guidelines are not tested.

Storage temperature	-65 °C to +150 °C
Ambient temperature with power applied	-55 °C to +125 °C
Supply voltage to ground potential	-0.2 V to $V_{CC(max)} + 0.2$ V
DC voltage applied to outputs in High Z state ^[4, 5]	-0.2 V to $V_{CC(max)} + 0.2$ V

DC input voltage ^[4, 5]	-0.2 V to $V_{CC(max)} + 0.2$ V
Output current into outputs (LOW)	20 mA
Static discharge voltage (per MIL-STD-883, method 3015)	> 2001 V
Latch up current	> 200 mA

Operating Range

Device	Range	Ambient Temperature	$V_{CC}^{[6]}$
CY62177EV18LL	Industrial	-40 °C to +85 °C	1.65 V to 2.25 V

Electrical Characteristics

Over the Operating Range

Parameter	Description	Test Conditions	70 ns			Unit
			Min	Typ ^[7]	Max	
V_{OH}	Output HIGH voltage	$I_{OH} = -0.1$ mA $V_{CC} = 1.65$ V	1.4	–	–	V
V_{OL}	Output LOW voltage	$I_{OL} = 0.1$ mA $V_{CC} = 1.65$ V	–	–	0.2	V
V_{IH}	Input HIGH voltage	$V_{CC} = 1.65$ V to 2.25 V	1.4	–	$V_{CC} + 0.2$ V	V
$V_{IL}^{[8]}$	Input LOW voltage	$V_{CC} = 1.65$ V to 2.25 V	-0.2	–	0.4	V
I_{IX}	Input leakage current	$GND \leq V_I \leq V_{CC}$	-1	–	+1	μA
I_{OZ}	Output leakage current	$GND \leq V_O \leq V_{CC}$, Output Disabled	-1	–	+1	μA
I_{CC}	V_{CC} operating supply current	$f = f_{Max} = 1/t_{RC}$ $V_{CC} = V_{CC(max)}$ $I_{OUT} = 0$ mA CMOS levels	–	35	45	mA
		$f = 1$ MHz	–	4.5	5.5	mA
$I_{SB2}^{[9, 10]}$	Automatic CE power down current – CMOS inputs	$\overline{CE}_1 \geq V_{CC} - 0.2$ V or $CE_2 \leq 0.2$ V or $(\overline{BHE}$ and $\overline{BLE}) \geq V_{CC} - 0.2$ V, $V_{IN} \geq V_{CC} - 0.2$ V or $V_{IN} \leq 0.2$ V, $f = 0$, $V_{CC} = V_{CC(max)}$	–	3	25	μA

Notes

- $V_{IL(min)}$ = -2.0 V for pulse durations less than 20 ns.
- $V_{IH(max)}$ = $V_{CC} + 0.75$ V for pulse durations less than 20 ns.
- Full Device AC operation assumes a 100 μs ramp time from 0 to V_{CC} (min) and 200 μs wait time after V_{CC} stabilization.
- Typical values are included for reference only and are not guaranteed or tested. Typical values are measured at $V_{CC} = V_{CC(typ)}$, $T_A = 25$ °C.
- Under DC conditions the device meets a V_{IL} of 0.8 V. However, in dynamic conditions Input LOW Voltage applied to the device must not be higher than 0.7 V.
- The BYTE pin in the 48-TSOP I package has to be tied to V_{CC} to use the device as a 2 M x 16 SRAM. The 48-TSOP I package can also be used as a 4 M x 8 SRAM by tying the BYTE signal to V_{SS} . In the 4 M x 8 configuration, Pin 45 is A21, while BHE, BLE, and I/O_3 to I/O_{14} pins are not used.
- Chip enables (\overline{CE}_1 and CE_2), byte enables (\overline{BHE} and \overline{BLE}) and BYTE need to be tied to CMOS levels to meet the I_{SB2} / I_{CCDR} spec. Other inputs can be left floating.

Capacitance

Parameter ^[11]	Description	Test Conditions	Max	Unit
C _{IN}	Input capacitance	T _A = 25 °C, f = 1 MHz, V _{CC} = V _{CC(typ)}	15	pF
C _{OUT}	Output capacitance		15	pF

Thermal Resistance

Parameter ^[11]	Description	Test Conditions	FBGA	TSOPI	Unit
Θ _{JA}	Thermal resistance (junction to ambient)	Still air, soldered on a 3 × 4.5 inch, 2-layer printed circuit board	38.10	44.66	°C/W
Θ _{JC}	Thermal resistance (junction to case)		7.54	12.12	°C/W

AC Test Loads and Waveforms

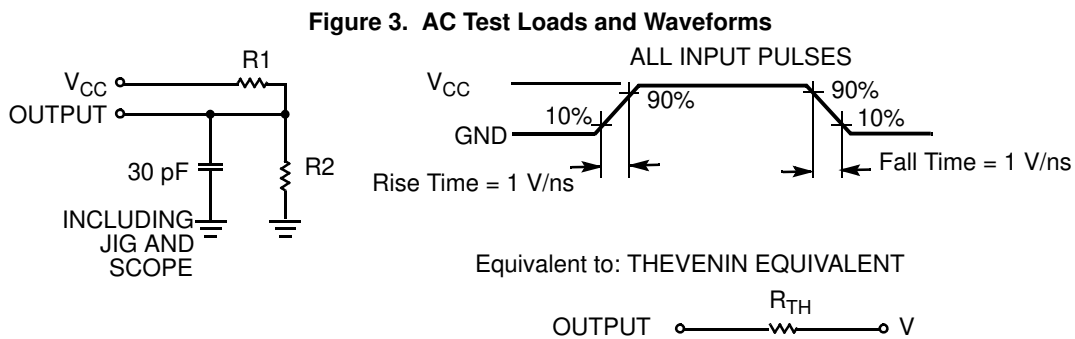

Table 1. AC Test Loads

Parameters	Value	Unit
R1	13500	Ω
R2	10800	Ω
R _{TH}	6000	Ω
V _{TH}	0.80	V

Note

11. Tested initially and after any design or process changes that may affect these parameters.

Data Retention Characteristics

Over the Operating Range

Parameter	Description	Conditions	Min	Typ ^[12]	Max	Unit
V_{DR}	V_{CC} for data retention		1.0	–	–	V
I_{CCDR} ^[13]	Data retention current	$V_{CC} = 1.0$ V, $\overline{CE}_1 \geq V_{CC} - 0.2$ V or $CE_2 \leq 0.2$ V, or $(\overline{BHE}$ and $\overline{BLE}) \geq V_{CC} - 0.2$ V, $V_{IN} \geq V_{CC} - 0.2$ V or $V_{IN} \leq 0.2$ V	–	–	17	μ A
t_{CDR} ^[14]	Chip deselect to data retention time		0	–	–	ns
t_R ^[15]	Operation recovery time		70	–	–	ns

Data Retention Waveform

Figure 4. Data Retention Waveform^[16]

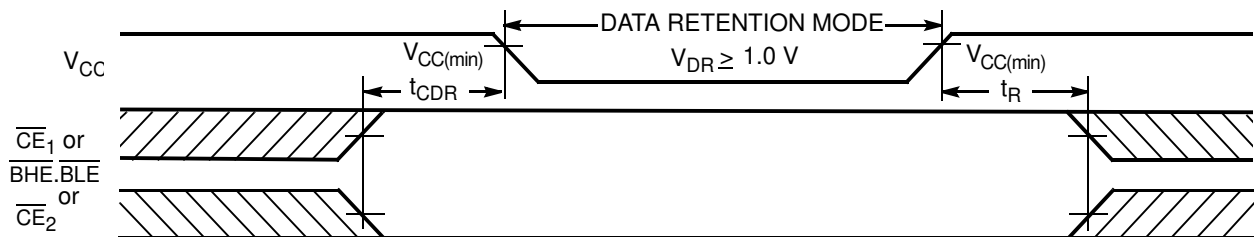

Notes

12. Typical values are included for reference only and are not guaranteed or tested. Typical values are measured at $V_{CC} = V_{CC(typ)}$, $T_A = 25$ °C.
13. Chip enables (\overline{CE}_1 and CE_2), byte enables (\overline{BHE} and \overline{BLE}) and \overline{BYTE} need to be tied to CMOS levels to meet the I_{SB2} / I_{CCDR} spec. Other inputs can be left floating.
14. Tested initially and after any design or process changes that may affect these parameters.
15. Full device operation requires linear V_{CC} ramp from V_{DR} to $V_{CC(min)} \geq 100$ μ s or stable at $V_{CC(min)} \geq 100$ μ s.
16. $\overline{BHE.BLE}$ is the AND of both \overline{BHE} and \overline{BLE} . Chip is deselected by either disabling the chip enable signals or by disabling both \overline{BHE} and \overline{BLE} .

Switching Characteristics

Over the Operating Range

Parameter [17, 18]	Description	70 ns		Unit
		Min	Max	
Read Cycle				
t_{RC}	Read cycle time	70	–	ns
t_{AA}	Address to data valid	–	70	ns
t_{OHA}	Data hold from address change	10	–	ns
t_{ACE}	\overline{CE}_1 LOW and CE_2 HIGH to data valid	–	70	ns
t_{DOE}	\overline{OE} LOW to data valid	–	35	ns
t_{LZOE}	\overline{OE} LOW to Low Z ^[19]	5	–	ns
t_{HZOE}	\overline{OE} HIGH to High Z ^[19, 20]	–	25	ns
t_{LZCE}	\overline{CE}_1 LOW and CE_2 HIGH to Low Z ^[19]	10	–	ns
t_{HZCE}	\overline{CE}_1 HIGH and CE_2 LOW to High Z ^[19, 20]	–	25	ns
t_{PU}	\overline{CE}_1 LOW and CE_2 HIGH to power up	0	–	ns
t_{PD}	\overline{CE}_1 HIGH and CE_2 LOW to power down	–	70	ns
t_{DBE}	$\overline{BLE}/\overline{BHE}$ LOW to data valid	–	70	ns
t_{LZBE}	$\overline{BLE}/\overline{BHE}$ LOW to Low Z ^[19]	10	–	ns
t_{HZBE}	$\overline{BLE}/\overline{BHE}$ HIGH to HIGH Z ^[19, 20]	–	25	ns
Write Cycle [21, 22]				
t_{WC}	Write cycle time	70	–	ns
t_{SCE}	\overline{CE}_1 LOW and CE_2 HIGH to write end	60	–	ns
t_{AW}	Address setup to write end	60	–	ns
t_{HA}	Address hold from write end	0	–	ns
t_{SA}	Address setup to write start	0	–	ns
t_{PWE}	\overline{WE} pulse width	45	–	ns
t_{BW}	$\overline{BLE}/\overline{BHE}$ LOW to write end	60	–	ns
t_{SD}	Data setup to write end	30	–	ns
t_{HD}	Data hold from Write End	0	–	ns
t_{HZWE}	\overline{WE} LOW to High Z ^[19, 20]	–	25	ns
t_{LZWE}	\overline{WE} HIGH to Low Z ^[19]	10	–	ns

Notes

17. Test conditions for all parameters other than tristate parameters assume signal transition time of 1 V/ns, timing reference levels of $V_{CC(typ)}/2$, input pulse levels of 0 to $V_{CC(typ)}$, and output loading of the specified I_{OL}/I_{OH} as shown in Table 1 on page 5.
18. In an earlier revision of this device, under a specific application condition, READ and WRITE operations were limited to switching of the byte enable and/or chip enable signals as described in the Application Notes AN13842 and AN66311. However, the issue has been fixed and in production now, and hence, these Application Notes are no longer applicable. They are available for download on our website as they contain information on the date code of the parts, beyond which the fix has been in production.
19. At any given temperature and voltage condition, t_{HZCE} is less than t_{LZCE} , t_{HZBE} is less than t_{LZBE} , t_{HZOE} is less than t_{LZOE} , and t_{HZWE} is less than t_{LZWE} for any given device.
20. t_{HZOE} , t_{HZCE} , t_{HZBE} , and t_{HZWE} transitions are measured when the outputs enter a high impedance state.
21. The internal Write time of the memory is defined by the overlap of \overline{WE} , $CE_1 = V_{IL}$, BHE and/or $BLE = V_{IL}$, and $CE_2 = V_{IH}$. All signals must be ACTIVE to initiate a write and any of these signals can terminate a write by going INACTIVE. The data input setup and hold timing should be referenced to the edge of the signal that terminates the write.
22. The minimum write cycle pulse width for Write Cycle No. 3 (\overline{WE} controlled, \overline{OE} LOW) should be equal to the sum of t_{SD} and t_{HZWE} .

Switching Waveforms

Figure 5. Read Cycle 1 (Address Transition Controlled) [23, 24]

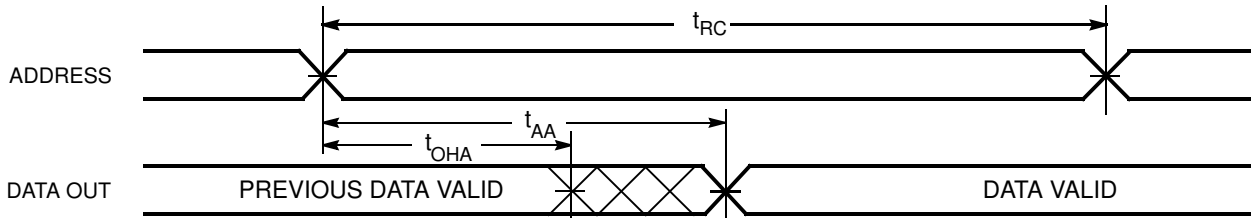
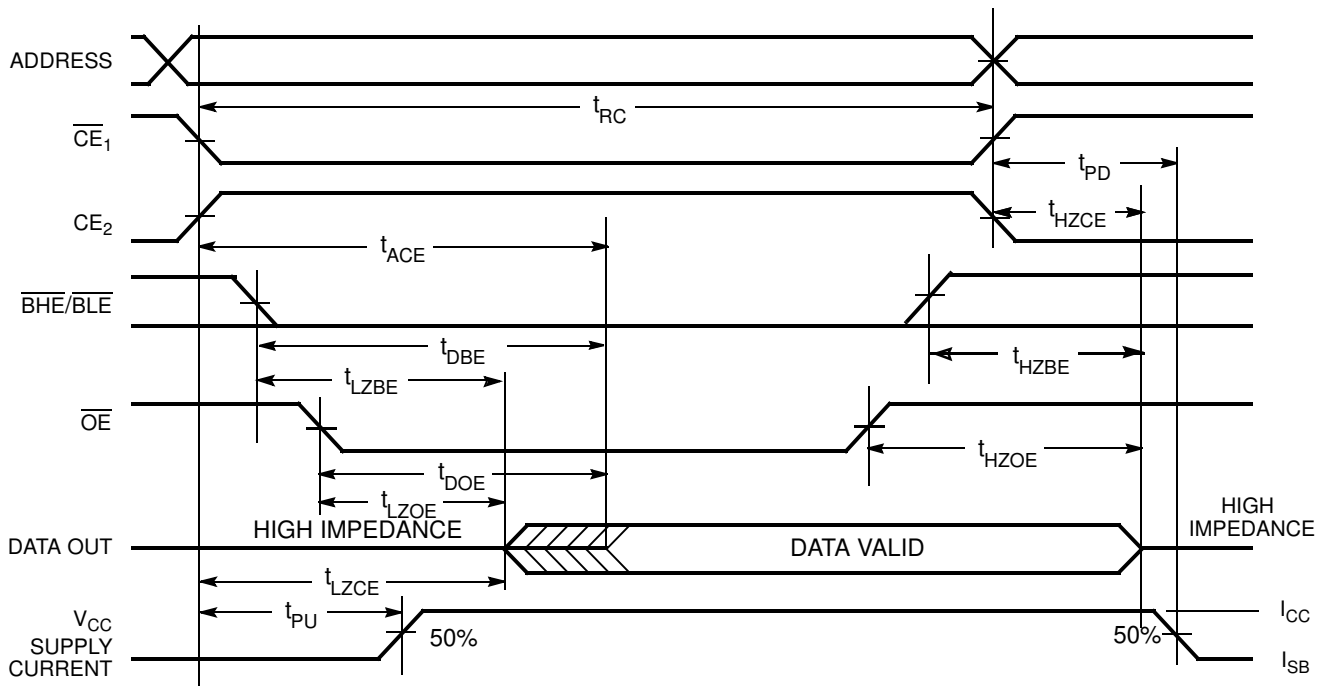

Figure 6. Read Cycle 2 (\overline{OE} Controlled) [24, 25]



Notes

23. The device is continuously selected. \overline{OE} , $\overline{CE}_1 = V_{IL}$, \overline{BHE} and/or $\overline{BLE} = V_{IL}$, and $CE_2 = V_{IH}$.

24. \overline{WE} is HIGH for read cycle.

25. Address valid prior to or coincident with \overline{CE}_1 , \overline{BHE} , \overline{BLE} transition LOW and CE_2 transition HIGH.

Switching Waveforms (continued)

Figure 7. Write Cycle 1 (\overline{WE} Controlled) [26, 27, 28, 29]

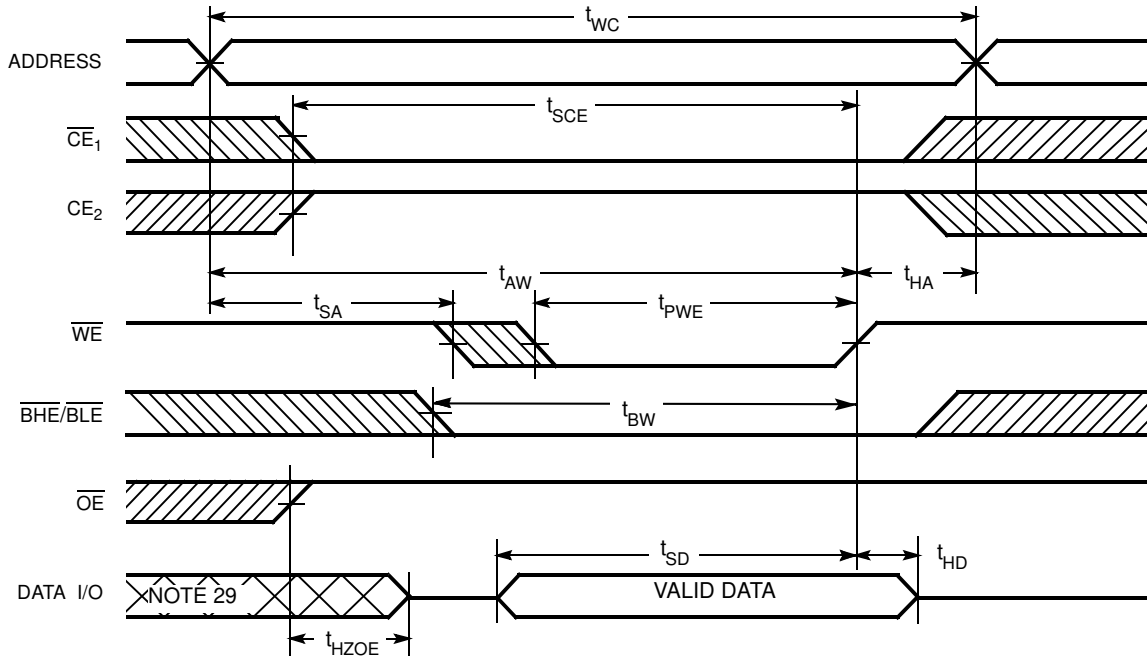
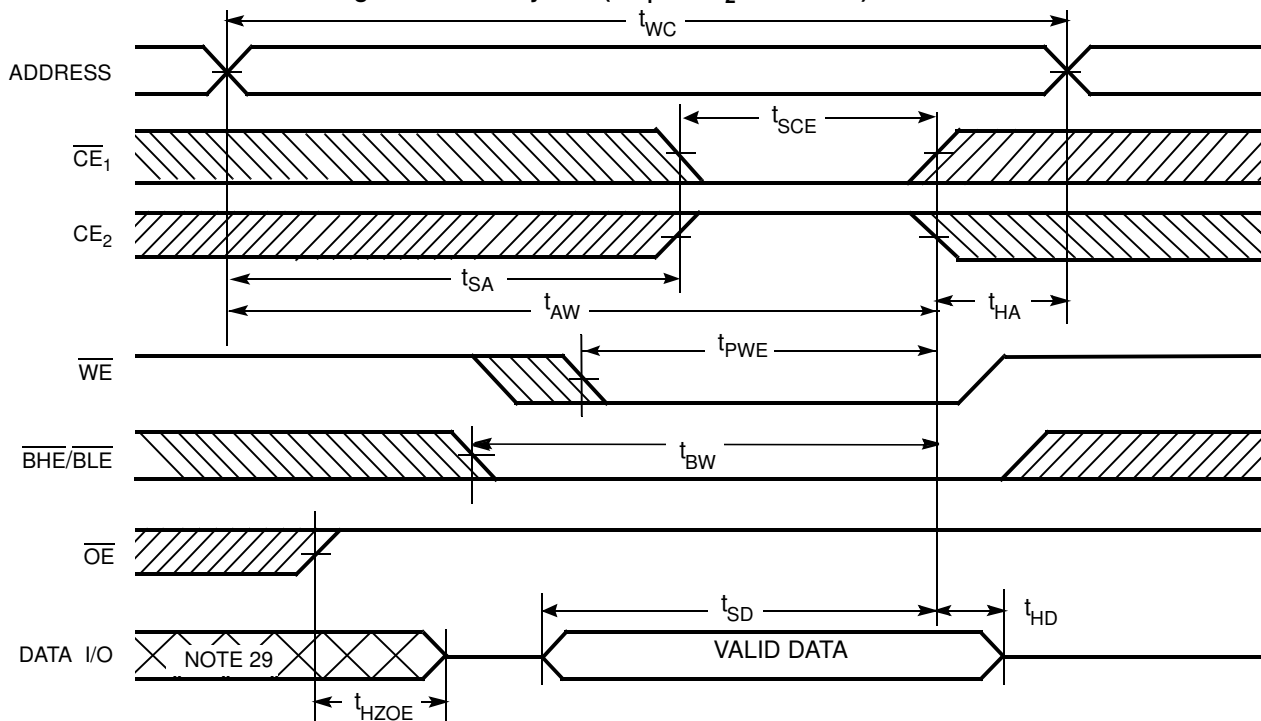

Figure 8. Write Cycle 2 ($\overline{CE_1}$ or $\overline{CE_2}$ Controlled) [26, 27, 28, 29]



Notes

- 26. The internal Write time of the memory is defined by the overlap of \overline{WE} , $\overline{CE_1} = V_{IL}$, \overline{BHE} and/or $\overline{BLE} = V_{IL}$, and $CE_2 = V_{IH}$. All signals must be ACTIVE to initiate a write and any of these signals can terminate a write by going INACTIVE. The data input setup and hold timing should be referenced to the edge of the signal that terminates the write.
- 27. Data I/O is high impedance if $\overline{OE} = V_{IH}$.
- 28. If $\overline{CE_1}$ goes HIGH and CE_2 goes LOW simultaneously with $\overline{WE} = V_{IH}$, the output remains in a high-impedance state.
- 29. During this period the I/Os are in output state and input signals should not be applied.

Switching Waveforms (continued)

Figure 9. Write Cycle 3 (\overline{WE} Controlled, \overline{OE} LOW) [30, 31, 32]

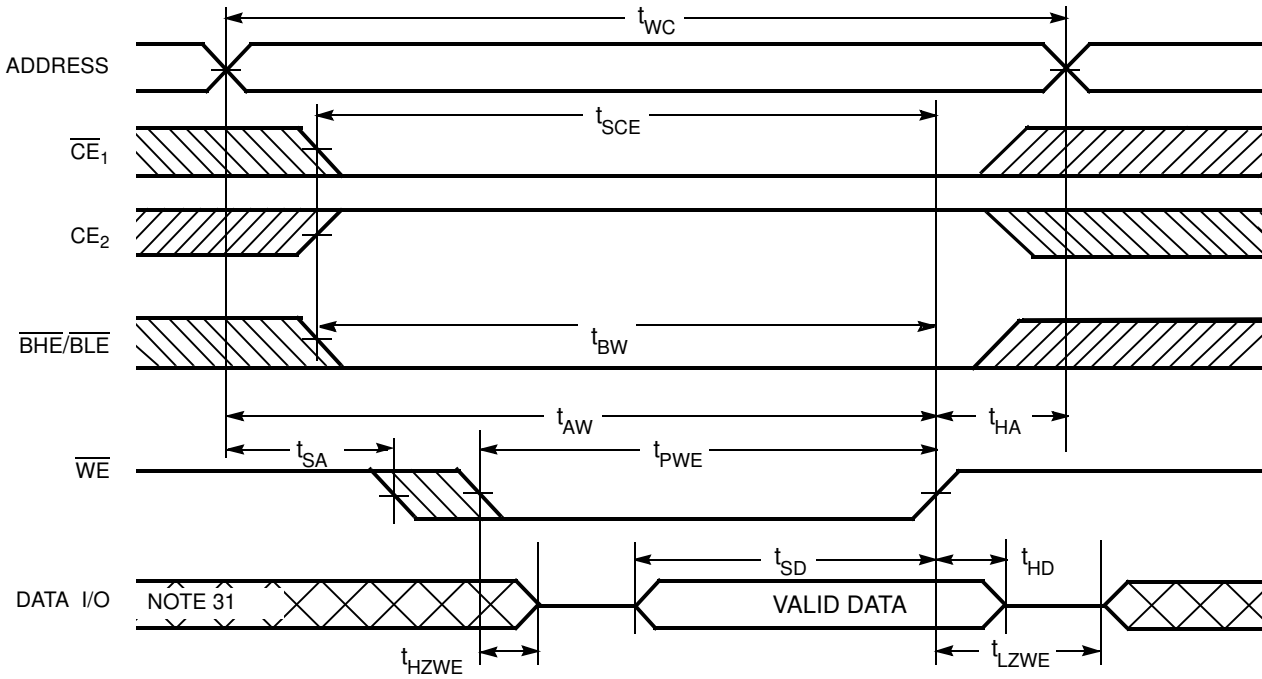
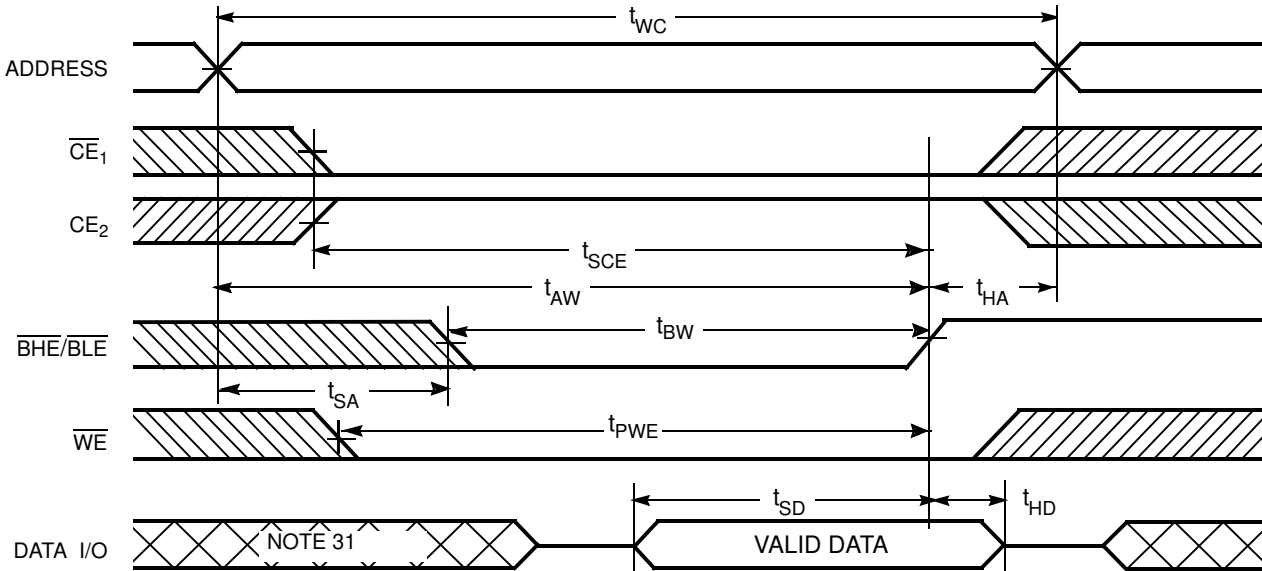

Figure 10. Write Cycle 4 ($\overline{BHE}/\overline{BLE}$ Controlled, \overline{OE} LOW) [30, 32]



Notes

30. If \overline{CE}_1 goes HIGH and CE_2 goes LOW simultaneously with $\overline{WE} = V_{IH}$, the output remains in a high-impedance state.

31. During this period the I/Os are in output state and input signals should not be applied.

32. The minimum write cycle pulse width should be equal to the sum of t_{SD} and t_{HZWE} .

Truth Table

\overline{CE}_1	CE_2	\overline{WE}	\overline{OE}	\overline{BHE}	\overline{BLE}	Inputs Outputs	Mode	Power
H	X ^[33]	X	X	X	X	High Z	Deselect/Power Down	Standby (I _{SB})
X ^[33]	L	X	X	X	X	High Z	Deselect/Power Down	Standby (I _{SB})
X ^[33]	X ^[33]	X	X	H	H	High Z	Deselect/Power Down	Standby (I _{SB})
L	H	H	L	L	L	Data Out (I/O ₀ –I/O ₁₅)	Read	Active (I _{CC})
L	H	H	L	H	L	High Z (I/O ₈ –I/O ₁₅); Data Out (I/O ₀ –I/O ₇)	Read	Active (I _{CC})
L	H	H	L	L	H	Data Out (I/O ₈ –I/O ₁₅); High Z (I/O ₀ –I/O ₇)	Read	Active (I _{CC})
L	H	L	X	L	L	Data In (I/O ₀ –I/O ₁₅)	Write	Active (I _{CC})
L	H	L	X	H	L	High Z (I/O ₈ –I/O ₁₅); Data In (I/O ₀ –I/O ₇)	Write	Active (I _{CC})
L	H	L	X	L	H	Data In (I/O ₈ –I/O ₁₅); High Z (I/O ₀ –I/O ₇)	Write	Active (I _{CC})
L	H	H	H	L	H	High Z	Output Disabled	Active (I _{CC})
L	H	H	H	H	L	High Z	Output Disabled	Active (I _{CC})
L	H	H	H	L	L	High Z	Output Disabled	Active (I _{CC})

Note

33. The 'X' (Don't care) state for the chip enables in the truth table refer to the logic state (either HIGH or LOW). Intermediate voltage levels on these pins is not permitted.

Ordering Information

Speed (ns)	Ordering Code	Package Diagram	Package Type	Operating Range
70	CY62177EV18LL-70BAXI	51-85191	48 ball FBGA (8 × 9.5 × 1.2 mm) Pb-free	Industrial

Contact your local Cypress sales representative for availability of these parts.

Ordering Code Definitions

CY 621 7 7 E V18 LL -70 Z,BA X I

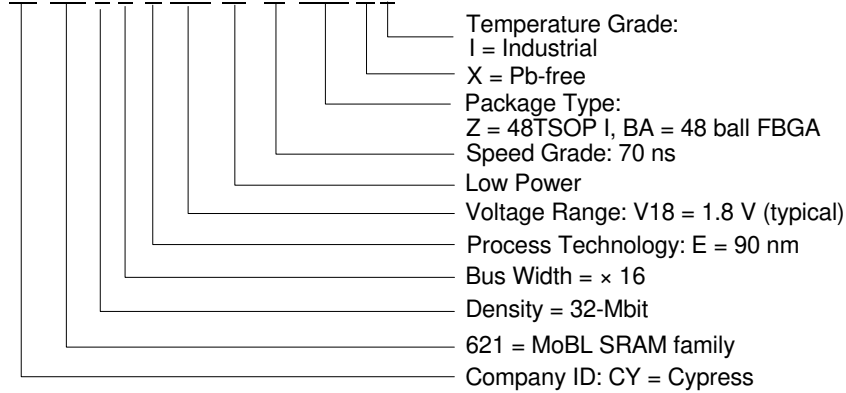

Package Diagrams (continued)

Figure 12. 48-pin TSOP I (12 × 18.4 × 1.0 mm) Package Outline, 51-85183

DIMENSIONS IN INCHES[MM] MIN. MAX.
JEDEC # MO-142

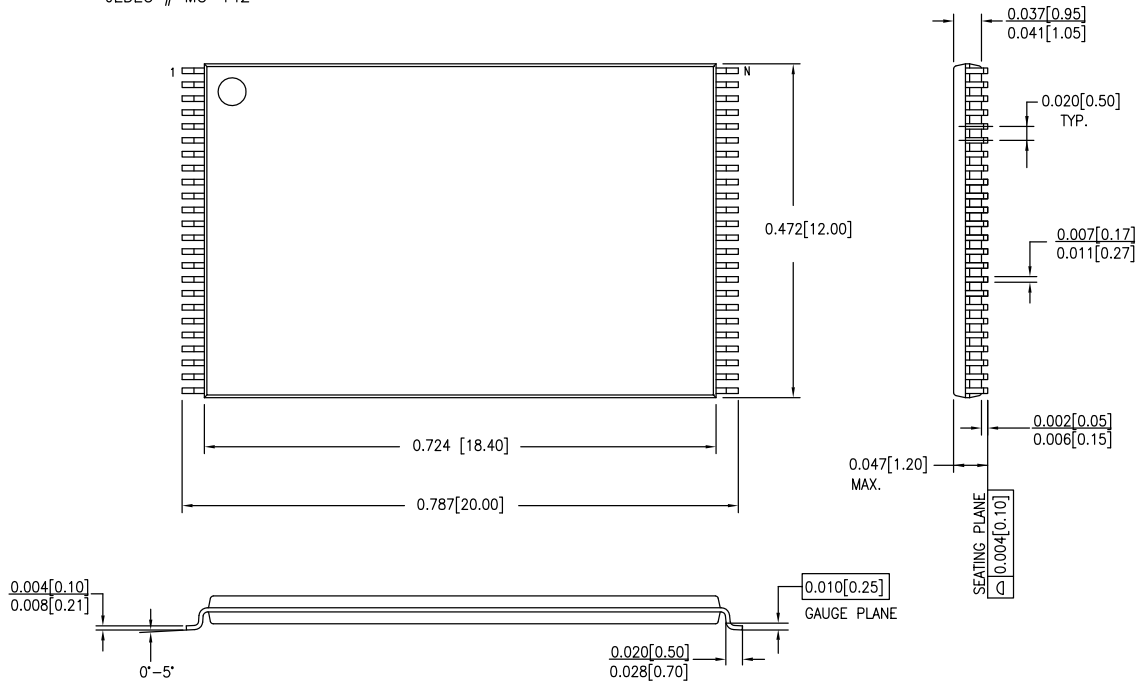

51-85183 *C

Acronyms

Acronym	Description
$\overline{\text{BHE}}$	Byte High Enable
$\overline{\text{BLE}}$	Byte Low Enable
$\overline{\text{CE}}$	Chip Enable
CMOS	Complementary Metal Oxide Semiconductor
I/O	Input/Output
$\overline{\text{OE}}$	Output Enable
SRAM	Static Random Access Memory
TSOP	Thin Small Outline Package
$\overline{\text{WE}}$	Write Enable

Document Conventions

Units of Measure

Symbol	Unit of Measure
°C	degree Celsius
MHz	megahertz
μA	microampere
mA	milliampere
ms	millisecond
ns	nanosecond
Ω	ohm
%	percent
pF	picofarad
ps	picosecond
V	volt
W	watt

Document History Page

Document Title: CY62177EV18 MoBL [®] , 32-Mbit (2 M × 16 / 4 M × 8) Static RAM Document Number: 001-76091				
Revision	ECN	Orig. of Change	Submission Date	Description of Change
**	3528465	AJU	02/17/2012	New data sheet.
*A	4116295	MEMJ	09/10/2013	Changed status from Preliminary to Final. Updated Features : Added 48-ball FBGA package related information. Updated Ordering Information (Updated part numbers). Updated Package Diagrams : spec 51-85191 – Changed revision from *B to *C. Updated in new template.
*B	4301112	NILE	03/07/2014	Updated Switching Characteristics : Added Note 18 and referred the same note in “Parameter” column. Completing Sunset Review.
*C	4571881	NILE	11/28/2014	Added related documentation hyperlink in page 1. Added Note 22 in Switching Characteristics . Added note reference 22 in the Switching Characteristics table. Added Note 32 in Switching Waveforms . Added note reference 32 in Figure 9 .

Sales, Solutions, and Legal Information

Worldwide Sales and Design Support

Cypress maintains a worldwide network of offices, solution centers, manufacturer's representatives, and distributors. To find the office closest to you, visit us at [Cypress Locations](#).

Products

Automotive	cypress.com/go/automotive
Clocks & Buffers	cypress.com/go/clocks
Interface	cypress.com/go/interface
Lighting & Power Control	cypress.com/go/powerpsoc cypress.com/go/plc
Memory	cypress.com/go/memory
PSoC	cypress.com/go/psoc
Touch Sensing	cypress.com/go/touch
USB Controllers	cypress.com/go/USB
Wireless/RF	cypress.com/go/wireless

PSoC[®] Solutions

[psoc.cypress.com/solutions](#)
[PSoC 1](#) | [PSoC 3](#) | [PSoC 4](#) | [PSoC 5LP](#)

Cypress Developer Community

[Community](#) | [Forums](#) | [Blogs](#) | [Video](#) | [Training](#)

Technical Support

[cypress.com/go/support](#)

© Cypress Semiconductor Corporation, 2012-2014. The information contained herein is subject to change without notice. Cypress Semiconductor Corporation assumes no responsibility for the use of any circuitry other than circuitry embodied in a Cypress product. Nor does it convey or imply any license under patent or other rights. Cypress products are not warranted nor intended to be used for medical, life support, life saving, critical control or safety applications, unless pursuant to an express written agreement with Cypress. Furthermore, Cypress does not authorize its products for use as critical components in life-support systems where a malfunction or failure may reasonably be expected to result in significant injury to the user. The inclusion of Cypress products in life-support systems application implies that the manufacturer assumes all risk of such use and in doing so indemnifies Cypress against all charges.

Any Source Code (software and/or firmware) is owned by Cypress Semiconductor Corporation (Cypress) and is protected by and subject to worldwide patent protection (United States and foreign), United States copyright laws and international treaty provisions. Cypress hereby grants to licensee a personal, non-exclusive, non-transferable license to copy, use, modify, create derivative works of, and compile the Cypress Source Code and derivative works for the sole purpose of creating custom software and or firmware in support of licensee product to be used only in conjunction with a Cypress integrated circuit as specified in the applicable agreement. Any reproduction, modification, translation, compilation, or representation of this Source Code except as specified above is prohibited without the express written permission of Cypress.

Disclaimer: CYPRESS MAKES NO WARRANTY OF ANY KIND, EXPRESS OR IMPLIED, WITH REGARD TO THIS MATERIAL, INCLUDING, BUT NOT LIMITED TO, THE IMPLIED WARRANTIES OF MERCHANTABILITY AND FITNESS FOR A PARTICULAR PURPOSE. Cypress reserves the right to make changes without further notice to the materials described herein. Cypress does not assume any liability arising out of the application or use of any product or circuit described herein. Cypress does not authorize its products for use as critical components in life-support systems where a malfunction or failure may reasonably be expected to result in significant injury to the user. The inclusion of Cypress' product in a life-support systems application implies that the manufacturer assumes all risk of such use and in doing so indemnifies Cypress against all charges.

Use may be limited by and subject to the applicable Cypress software license agreement.