

OPTION G

- NOTES:
- MATERIAL:
HOUSING: POLYESTER(PBT), GLASS FILLED, UL94 V-0;
COLOR: BLACK
TERMINAL: PHOSPHOR BRONZE
 - FINISH:
15 GOLD: 0.38 MICROMETERS/15 MICROINCHES MINIMUM GOLD IN
191 MICROMETERS/75 MICROINCHES MINIMUM TIN
OVER NICKEL UNDERPLATE OVERALL
 - TO BE USED WITH 28 AWG STRANDED WIRE WITH (1.35)/.053
DIAMETER MAXIMUM INSULATION
 - SEE TABLE FOR AVAILABLE CIRCUIT SIZES
 - STANDARD PACKAGING PER PK-70873-0001. OPTIONAL PACKAGING
MAY BE AVAILABLE. REQUEST DRAWING PK-70400
 - PARTS STACKABLE END TO END ON (2.54)/.100 CENTERS
 - PRODUCT SPECIFICATION: PS-70400
 - SEE DRAWING SDA-70400-**** (SHEET 3) FOR OPTIONAL
HOUSING DETAILS
 - 4 CIRCUIT SHOWN. 3-25 CIRCUITS HAVE 2 RIBS
 - TO MATE WITH MOLEX PART NUMBERS: A-70373-****,
A-70375-****, A-70389-****, A-70391-****,
A-70107-****, A-70018-****, A-70543-****,
A-70553-****, A-70541-****, A-70551-****,
A-70545-****, A-70555-****
 - 2 CIRCUIT ASSEMBLIES SUPPLIED AS GROUPED PAIRS

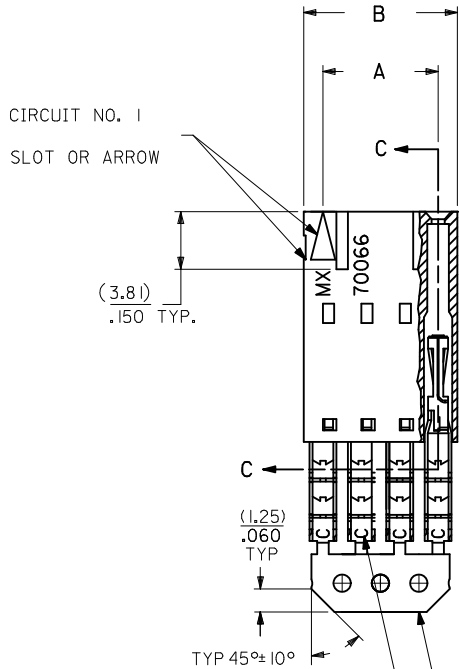

SECTION C-C

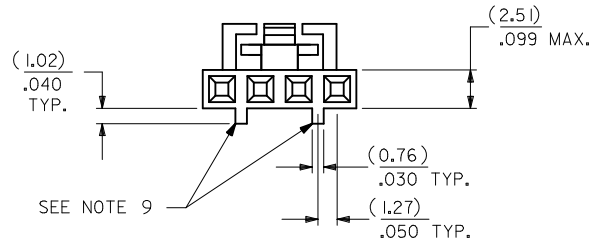
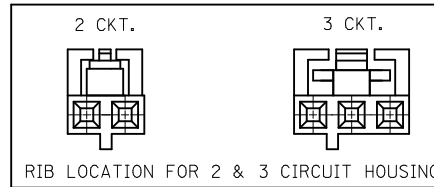
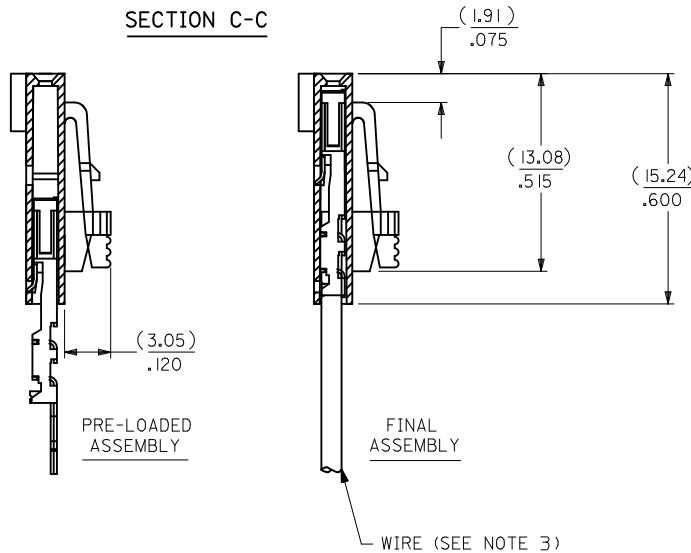

| CKT. SIZE | A | B | EDP. NO. |
|-----------|--------------------|--------------------|------------|
| 2 | (2.54) .100 | (5.05) .199 | 14-56-2026 |
| 3 | (5.08) .200 | (7.59) .299 | 14-56-2036 |
| 4 | (7.62) .300 | (10.13) .399 | 14-56-2046 |
| 5 | (10.16) .400 | (12.67) .499 | 14-56-2056 |
| 6 | (12.70) .500 | (15.21) .599 | 14-56-2066 |
| 7 | (15.24) .600 | (17.75) .699 | 14-56-2076 |
| 8 | (17.78) .700 | (20.29) .799 | 14-56-2086 |
| 9 | (20.32) .800 | (22.83) .899 | 14-56-2096 |
| 10 | (22.86) .900 | (25.37) .999 | 14-56-2106 |
| 11 | (25.54) 1.000 | (27.91) 1.099 | 14-56-2116 |
| 12 | (27.94) 1.100 | (30.45) 1.199 | 14-56-2126 |
| 13 | (30.48) 1.200 | (32.99) 1.299 | 14-56-2136 |
| 14 | (33.02) 1.300 | (35.53) 1.399 | 14-56-2146 |
| 15 | (35.56) 1.400 | (38.07) 1.499 | 14-56-2156 |
| 16 | (38.01) 1.500 | (40.61) 1.599 | 14-56-2166 |
| 17 | (40.64) 1.600 | (43.15) 1.699 | 14-56-2176 |
| 18 | (43.18) 1.700 | (45.69) 1.799 | 14-56-2186 |
| 19 | (45.72) 1.800 | (48.23) 1.899 | 14-56-2196 |
| 20 | (48.26) 1.900 | (50.77) 1.999 | 14-56-2206 |
| 21 | (50.80) 2.000 | (53.31) 2.099 | 14-56-2216 |
| 22 | (53.34) 2.100 | (55.85) 2.199 | 14-56-2226 |
| 23 | (55.88) 2.200 | (58.39) 2.299 | 14-56-2236 |
| 24 | (58.42) 2.300 | (60.93) 2.399 | 14-56-2246 |
| 25 | (60.96) 2.400 | (63.47) 2.499 | 14-56-2256 |

| I.D. SLOT CODE TO WIRE GAUGE CHART | |
|------------------------------------|------------|
| I.D. SLOT CODE | WIRE GAUGE |
| C | 28 AWG. |

| PLATING CODE (STRIPE ON CARRIER STRIP) | |
|--|--------|
| PLATING | COLOR |
| 15 GOLD | YELLOW |

| | | | | | |
|--|--------------------------------------|--|--|---|------------------------|
| REMOVE ENG NO. EC NO: UCP2011-1110 DRW:MSI BARRA 2010/10/19 CHK:DJ MORGAN 2010/10/19 APPR:SMILLER 2010/11/24 | QUALITY SYMBOLS ▽=0 ▽=0 ▽=0 | GENERAL TOLERANCES (UNLESS SPECIFIED) mm INCH 4 PLACES ± --- ± --- 3 PLACES ± --- ± .010 2 PLACES ± 0.25 ± .014 1 PLACE ± 0.35 ± --- ANGULAR ±1/2° | DIMENSION STYLE MM/IN DRAWN BY DATE MSI BARRA 2010/10/19 CHECKED BY DATE WAZ 1984/10/10 APPROVED BY DATE SMILLER 2010/11/24 | SCALE DESIGN UNITS INCH TITLE ASSEMBLY, SL CONNECTOR SINGLE ROW 2.54/.100 GRID | THIRD ANGLE PROJECTION |
| | | DRAFT WHERE APPLICABLE MUST REMAIN WITHIN DIMENSIONS | MATERIAL NO. SEE TABLE | DOCUMENT NO. SDA-70400-1016-1039 | SHEET NO. 1 OF 1 |
| | | THIS DRAWING CONTAINS INFORMATION THAT IS PROPRIETARY TO MOLEX INCORPORATED AND SHOULD NOT BE USED WITHOUT WRITTEN PERMISSION | | | |
| | | MOLEX MOLEX INCORPORATED | | | |