

13 12 11 10 9 8 7 6 5 4 3 2 1

J  
I  
H  
G  
F  
E  
D  
C  
B  
A

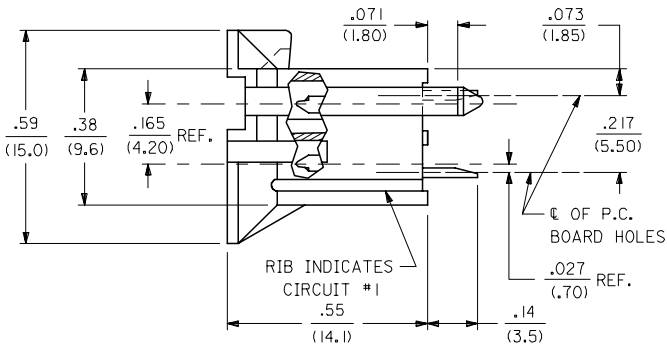

CIRCUIT SIZE	DIM. "A"	DIM. "B"	DIM. "C"	DIM. "D"	DIM. "E"
2	.520 (13.20)	—	.425 (10.80)	.370 (9.40)	.21 (5.4)
4	.685 (17.40)	.17 (4.2)	.590 (15.00)	.535 (13.60)	.38 (9.6)
6	.850 (21.60)	.33 (8.4)	.756 (19.20)	.701 (17.80)	.54 (13.8)
8	1.016 (25.80)	.50 (12.6)	.921 (23.40)	.866 (22.00)	.71 (18.0)
10	1.181 (30.00)	.66 (16.8)	1.087 (27.60)	1.031 (26.20)	.87 (22.2)
12	1.346 (34.20)	.83 (21.0)	1.252 (31.80)	1.197 (30.40)	1.04 (26.4)
14	1.512 (38.40)	.99 (25.2)	1.417 (36.00)	1.362 (34.60)	1.20 (30.6)
16	1.677 (42.60)	1.16 (29.4)	1.583 (40.20)	1.528 (38.80)	1.37 (34.8)
18	1.843 (46.80)	1.32 (33.6)	1.748 (44.40)	1.693 (43.00)	1.54 (39.0)
20	2.008 (51.00)	1.49 (37.8)	1.913 (48.60)	1.858 (47.20)	1.70 (43.2)
22	2.173 (55.20)	1.65 (42.0)	2.079 (52.80)	2.024 (51.40)	1.87 (47.4)
24	2.339 (59.40)	1.82 (46.2)	2.244 (57.00)	2.189 (55.60)	2.03 (51.6)

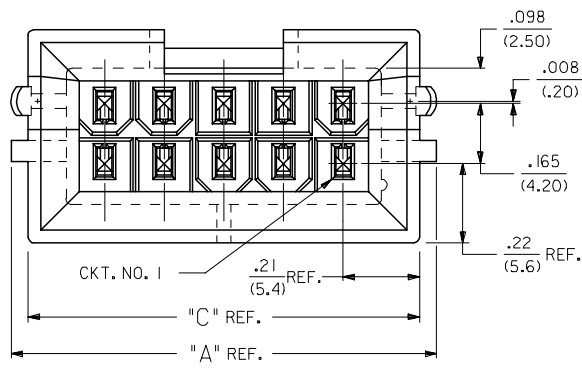
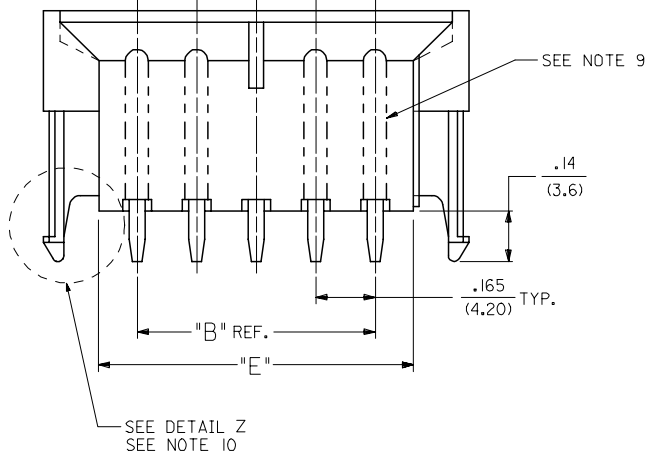
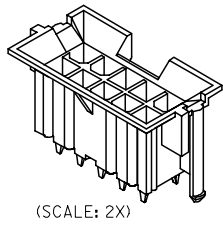

LEGEND:  
A - 42440 - \*\*\*  
BASE NUMBER  
CIRCUIT SIZE (02-24)  
PLATING (SEE NOTE 2.)  
HOUSING MAT'L. & OPTIONS (SEE NOTE 1.)

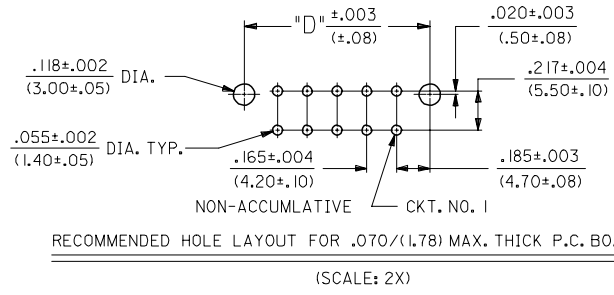

6	P
5	P
4	P
3	P1
2	P
1	P1
	REV

Part No.	Part Description	Material	Plating
---22, ---42	42474-***2I, 5556-PBGS*P	94V-0	PHOS. BRZ. GOLD
---12, ---32	42474-***1I, 5556-PBGS*P	94V-2	PHOS. BRZ. GOLD
---22, ---42, ---23, ---43	42474-***2I, 5556-GS*P	94V-0	BRASS GOLD
---12, ---32, ---13, ---33	42474-***1I, 5556-GS*P	94V-2	BRASS GOLD
---2I, ---4I	42474-***2I, 5556-PBS*P	94V-0	PHOS. BRZ. TIN
---1I, ---3I	42474-***1I, 5556-PBS*P	94V-2	PHOS. BRZ. TIN
---2I, ---4I	42474-***2I, 5556-S*P	94V-0	BRASS TIN
---1I, ---3I	42474-***1I, 5556-S*P	94V-2	BRASS TIN
---22, ---42	A-42385-***D2, ---D4	94V-0	PHOS. BRZ. GOLD
---12, ---32	A-42385-***C2, ---C4	94V-2	PHOS. BRZ. GOLD
---22, ---42, ---23, ---43	A-42385-***B2, ---B4	94V-0	BRASS GOLD
---12, ---32, ---13, ---33	A-42385-***A2, ---A4	94V-2	BRASS GOLD
---2I, ---4I	A-42385-***D1	94V-0	PHOS. BRZ. TIN
---1I, ---3I	A-42385-***C1	94V-2	PHOS. BRZ. TIN
---2I, ---4I	A-42385-***B1	94V-0	BRASS TIN
---1I, ---3I	A-42385-***A1	94V-2	BRASS TIN

SHEET 3, NOTE #9  
FC NO: UCP2007-2479  
DRAWN:LSCHMIDT 2007/04/04  
CHKD:IBELL 2007/04/11  
APPR:FSM TH 2007/04/16  
DESCRIPTION  
REV

QUALITY SYMBOLS  
=0  
=0

GENERAL TOLERANCES (UNLESS SPECIFIED)  
mm INCH  
4 PLACES ± --- ± ---  
3 PLACES ± --- ± .010  
2 PLACES ± 0.25 ± .015  
1 PLACE ± 0.38 ± ---  
ANGULAR ± 5 °

DIMENSION STYLE IN/MM  
SCALE 4:1  
DESIGN UNITS METRIC  
THIRD ANGLE PROJECTION

DRAWN BY GEP DATE 1989/04/06  
CHECKED BY RJF DATE 1989/04/06  
APPROVED BY RAS DATE 1989/04/06  
MATERIAL NO.  
DOCUMENT NO.

MINI-FIT B.M.I.  
VERTICAL HEADER ASSY  
WITH DRAIN HOLE OPTION

MOLEX INCORPORATED

SDA-42440-\*\*\*\*

SHEET NO. 1 OF 6

DRAFT WHERE APPLICABLE MUST REMAIN WITHIN DIMENSIONS

SEE CHART

THIS DRAWING CONTAINS INFORMATION THAT IS PROPRIETARY TO MOLEX INCORPORATED AND SHOULD NOT BE USED WITHOUT WRITTEN PERMISSION

12 11 10 9 8 7 6 5 4 3 2 1

NOTES:

- 1) MATERIAL:
  - HOUSING MATERIAL AND OPTIONS:
    - 1 = NYLON 6/6, UL 94V-2, COLOR: NATURAL, WITHOUT DRAIN HOLES
    - 2 = NYLON 6/6, UL 94V-0, COLOR: NATURAL, WITHOUT DRAIN HOLES
    - 3 = NYLON 6/6, UL 94V-2, COLOR: NATURAL, WITH DRAIN HOLES
    - 4 = NYLON 6/6, UL 94V-0, COLOR: NATURAL, WITH DRAIN HOLES
  - TERMINALS: BRASS
- 2) TERMINAL PLATING:
  - S = .000100/(0.00254) MIN. BRIGHT TIN OVER .000050/(0.00127) MIN. NICKEL
  - \*GS = .000030/(0.00076) MIN. SELECT GOLD AND .000100/(0.00254) MIN. SELECT MATTE TIN OVER .000050/(0.00127) MIN. NICKEL OVERALL
  - \*GS3 = .000050/(0.00127) MIN. SELECT GOLD AND .000100/(0.00254) MIN. SELECT MATTE TIN OVER .000050/(0.00127) MIN. NICKEL OVERALL
  - \*THE PRIMARY SHIPPING CARTON WILL BE LABELED "COMPLIANT TO RoHS DIRECTIVE 2002/95/EC AND ELV ANNEX II OF DIRECTIVE 200/53/EC"; CARTONS WITHOUT THIS LABEL MAY CONTAIN PRODUCT WITH TIN-LEAD PLATING.
- 3) PRODUCT SPECIFICATION AND PROCESSING PARAMETERS: PS-5556-002
- 4) PACKAGING: SEE CHARTS
- 5) 6-24 CIRCUIT PARTS MATE WITH MINI-FIT JR. RECEPTACLES #5557 AND HEADERS #42385 AND #42474; 2 AND 4 CIRCUIT PARTS MATE WITH 42385 AND 42474 HEADERS ONLY.
- 6) PART ALLOWS FOR UP TO .100/(2.54) MISALIGNMENT WITH MATING RECEPTACLE IN ANY DIRECTION. SEE MATING CONNECTOR DRAWINGS FOR SPECIFIC ALLOWANCES.
- 7) CONNECTOR IS NOT DESIGNED FOR CURRENT SHARING.
- 8) CONNECTOR ASSEMBLIES ARE NOT BE MATED OR UNMATED WHILE CIRCUITS ARE LIVE.
- 9) OPTIONAL RIBS MAY BE FOUND ON PARTS MANUFACTURED AFTER 08/11/1997. RIB LOCATION IS DETERMINED BY MOLD DESIGN FOR MANUFACTURING EASE AND THE LOCATION DOES NOT AFFECT PART FUNCTION OR PERFORMANCE. LOCATION OF RIBS MAY VARY ON PARTS WITHIN MAUFACTURING LOT OR SHIPMENT. THIS DRAWING SHOWS TYPICAL RIB LOCATIONS.
- 10) PARTS MANUFACTURED AFTER 8/15/1997 MAY HAVE REVISED LOCK PEG.
- 11) PART CONFORMS TO CLASS "B" REQUIREMENTS OF COSMETIC SPECIFICATION PS-45499-002.

SEE SHEET ONE FC NO: UCP2007-2479 DRAWN:LSCHMIDT 2007/04/04 CHKD:JBELL 2007/04/11 APPR:FSM TH 2007/04/16 P1	QUALITY SYMBOLS ▽=0 ▽=0	GENERAL TOLERANCES (UNLESS SPECIFIED)		DIMENSION STYLE IN/MM		SCALE ---	DESIGN UNITS METRIC	THIRD ANGLE PROJECTION		
		mm	INCH	DRAWN BY GEP	DATE 1989/04/06	TITLE MINI-FIT B.M.I. VERTICAL HEADER ASSY WITH DRAIN HOLE OPTION				
		4 PLACES ±---	±---	CHECKED BY RJF	DATE 1989/04/06	MOLEX INCORPORATED MATERIAL NO. SDA-42440-**** DOCUMENT NO. SHEET NO. 3 OF 6				
		3 PLACES ±---	±---	APPROVED BY RAS	DATE 1989/04/06					
2 PLACES ±---	±---	DRAFT WHERE APPLICABLE MUST REMAIN WITHIN DIMENSIONS		SEE CHART		THIS DRAWING CONTAINS INFORMATION THAT IS PROPRIETARY TO MOLEX INCORPORATED AND SHOULD NOT BE USED WITHOUT WRITTEN PERMISSION				
1 PLACE ±---	±---	ANGULAR ±---°		SIZE C						

	13	12	11	10	9	8	7	6	5	4	3	2	1				
J	PLATING: TIN (SEE NOTE 2 OPTION 'S')			PLATING: TIN (SEE NOTE 2 OPTION 'S')			PLATING: 30 M.I. SELECT GOLD (SEE NOTE 2 OPTION 'GS')			PLATING: 30 M.I. SELECT GOLD (SEE NOTE 2 OPTION 'GS')			J				
	DRAINS: WITHOUT DRAIN HOLES			DRAINS: WITHOUT DRAIN HOLES			DRAINS: WITHOUT DRAIN HOLES			DRAINS: WITHOUT DRAIN HOLES							
	PEGS: WITH PEGS			PEGS: WITH PEGS			PEGS: WITH PEGS			PEGS: WITH PEGS							
	MAT'L: 94V-2 [NATURAL]			MAT'L: 94V-0 [NATURAL]			MAT'L: 94V-2 [NATURAL]			MAT'L: 94V-0 [NATURAL]							
	PACKAGING: TRAY PER PK-42440-001			PACKAGING: TRAY PER PK-42440-001			PACKAGING: TRAY PER PK-42440-001			PACKAGING: TRAY PER PK-42440-001							
I	PART NO.	ENG NO.		CKTS	PART NO.	ENG NO.		CKTS	PART NO.	ENG NO.		CKTS	PART NO.	ENG NO.		CKTS	I
	NO EDP	A-42440-0211	-	2	NO EDP	A-42440-0221	-	2	NO EDP	A-42440-0212	-	2	NO EDP	A-42440-0222	-	2	
	15-24-6041	A-42440-0411	-	4	15-24-6042	A-42440-0421	-	4	15-28-6041	A-42440-0412	-	4	15-28-6042	A-42440-0422	-	4	
	NO EDP	A-42440-0611	-	6	NO EDP	A-42440-0621	-	6	NO EDP	A-42440-0612	-	6	NO EDP	A-42440-0622	-	6	
	NO EDP	A-42440-0811	-	8	NO EDP	A-42440-0821	-	8	NO EDP	A-42440-0812	-	8	NO EDP	A-42440-0822	-	8	
	15-24-6101	A-42440-1011	-	10	15-24-6102	A-42440-1021	-	10	15-28-6101	A-42440-1012	-	10	15-28-6102	A-42440-1022	-	10	
	NO EDP	A-42440-1211	-	12	NO EDP	A-42440-1221	-	12	NO EDP	A-42440-1212	-	12	NO EDP	A-42440-1222	-	12	
	15-24-6141	A-42440-1411	-	14	15-24-6142	A-42440-1421	-	14	15-28-6141	A-42440-1412	-	14	15-28-6142	A-42440-1422	-	14	
	15-24-6161	A-42440-1611	-	16	15-24-6162	A-42440-1621	-	16	15-28-6161	A-42440-1612	-	16	NO EDP	A-42440-1622	-	16	
H	15-24-6181	A-42440-1811	-	18	15-24-6182	A-42440-1821	-	18	15-28-6181	A-42440-1812	-	18	15-28-6182	A-42440-1822	-	18	H
	NO EDP	A-42440-2011	-	20	NO EDP	A-42440-2021	-	20	NO EDP	A-42440-2012	-	20	NO EDP	A-42440-2022	-	20	
	NO EDP	A-42440-2211	-	22	NO EDP	A-42440-2221	-	22	NO EDP	A-42440-2212	-	22	NO EDP	A-42440-2222	-	22	
	15-24-6241	A-42440-2411	-	24	15-24-6242	A-42440-2421	-	24	15-28-6241	A-42440-2412	-	24	15-28-6242	A-42440-2422	-	24	

G	PLATING: TIN (SEE NOTE 2 OPTION 'S')			PLATING: TIN (SEE NOTE 2 OPTION 'S')			PLATING: 30 M.I. SELECT GOLD (SEE NOTE 2 OPTION 'GS')			PLATING: 30 M.I. SELECT GOLD (SEE NOTE 2 OPTION 'GS')			G				
	DRAINS: WITH DRAIN HOLES			DRAINS: WITH DRAIN HOLES			DRAINS: WITH DRAIN HOLES			DRAINS: WITH DRAIN HOLES							
	PEGS: WITH PEGS			PEGS: WITH PEGS			PEGS: WITH PEGS			PEGS: WITH PEGS							
	MAT'L: 94V-2 [NATURAL]			MAT'L: 94V-0 [NATURAL]			MAT'L: 94V-2 [NATURAL]			MAT'L: 94V-0 [NATURAL]							
	PACKAGING: TRAY PER PK-42440-001			PACKAGING: TRAY PER PK-42440-001			PACKAGING: TRAY PER PK-42440-001			PACKAGING: TRAY PER PK-42440-001							
F	PART NO.	ENG NO.		CKTS	PART NO.	ENG NO.		CKTS	PART NO.	ENG NO.		CKTS	PART NO.	ENG NO.		CKTS	F
	NO EDP	A-42440-0231	-	2	NO EDP	A-42440-0241	-	2	NO EDP	A-42440-0232	-	2	NO EDP	A-42440-0242	-	2	
	15-24-6046	A-42440-0431	-	4	15-24-6047	A-42440-0441	-	4	15-28-6046	A-42440-0432	-	4	15-28-6047	A-42440-0442	-	4	
	15-24-6066	A-42440-0631	-	6	NO EDP	A-42440-0641	-	6	15-28-6066	A-42440-0632	-	6	NO EDP	A-42440-0642	-	6	
	NO EDP	A-42440-0831	-	8	NO EDP	A-42440-0841	-	8	NO EDP	A-42440-0832	-	8	NO EDP	A-42440-0842	-	8	
	15-24-6106	A-42440-1031	-	10	15-24-6107	A-42440-1041	-	10	15-28-6106	A-42440-1032	-	10	15-28-6107	A-42440-1042	-	10	
	NO EDP	A-42440-1231	-	12	NO EDP	A-42440-1241	-	12	NO EDP	A-42440-1232	-	12	NO EDP	A-42440-1242	-	12	
E	15-24-6146	A-42440-1431	-	14	15-24-6147	A-42440-1441	-	14	15-28-6146	A-42440-1432	-	14	15-28-6147	A-42440-1442	-	14	E
	NO EDP	A-42440-1631	-	16	NO EDP	A-42440-1641	-	16	NO EDP	A-42440-1632	-	16	NO EDP	A-42440-1642	-	16	
	15-24-6186	A-42440-1831	-	18	15-24-6187	A-42440-1841	-	18	15-28-6186	A-42440-1832	-	18	15-28-6187	A-42440-1842	-	18	
	NO EDP	A-42440-2031	-	20	NO EDP	A-42440-2041	-	20	NO EDP	A-42440-2032	-	20	NO EDP	A-42440-2042	-	20	
	NO EDP	A-42440-2231	-	22	NO EDP	A-42440-2241	-	22	NO EDP	A-42440-2232	-	22	NO EDP	A-42440-2242	-	22	
	15-24-6246	A-42440-2431	-	24	15-24-6247	A-42440-2441	-	24	15-28-6246	A-42440-2432	-	24	15-28-6247	A-42440-2442	-	24	

D														D
C														C
B														B
A														A

<b>STANDARDIZE NOTES</b> FCC NO: UCP2007-2152 DRWN:LSCHH1DT 2007/03/12 CHKD:ADERR 2007/03/19 APPR:FSM TH 2007/03/19 REVISIONS	QUALITY SYMBOLS 	GENERAL TOLERANCES (UNLESS SPECIFIED) mm INCH 4 PLACES ± --- ± --- 3 PLACES ± --- ± --- 2 PLACES ± --- ± --- 1 PLACE ± --- ± --- ANGULAR ± ---°	DIMENSION STYLE IN/MM DRAWN BY DATE GEP 1995/03/03 CHECKED BY DATE RJF 1995/03/03 APPROVED BY DATE RJF 1995/03/03	SCALE --- DESIGN UNITS METRIC THIRD ANGLE PROJECTION	MINI-FIT B.M.I. VERTICAL HEADER ASSY WITH DRAIN HOLE OPTION MOLEX INCORPORATED	MATERIAL NO. SDA-42440-**** SHEET NO. 4 OF 6
	DRAFT WHERE APPLICABLE MUST REMAIN WITHIN DIMENSIONS		SEE CHART	THIS DRAWING CONTAINS INFORMATION THAT IS PROPRIETARY TO MOLEX INCORPORATED AND SHOULD NOT BE USED WITHOUT WRITTEN PERMISSION		

	13	12	11	10	9	8	7	6	5	4	3	2	1														
J	PLATING: 50 M.I. SELECT GOLD (SEE NOTE 2 OPTION 'GS3')	DRAINS: WITHOUT DRAIN HOLES	PEGS: WITH PEGS	MAT'L: 94V-2 [NATURAL]	PACKAGING: TRAY PER PK-42440-001	PLATING: 50 M.I. SELECT GOLD (SEE NOTE 2 OPTION 'GS3')	DRAINS: WITHOUT DRAIN HOLES	PEGS: WITH PEGS	MAT'L: 94V-0 [NATURAL]	PACKAGING: TRAY PER PK-42440-001	PLATING: 50 M.I. SELECT GOLD (SEE NOTE 2 OPTION 'GS3')	DRAINS: WITH DRAIN HOLES	PEGS: WITH PEGS	MAT'L: 94V-0 [NATURAL]	PACKAGING: TRAY PER PK-42440-001	J											
I	PART NO. ENG NO. CKTS	NO EDP A-42440-02 I3 - 2	NO EDP A-42440-04 I3 - 4	NO EDP A-42440-06 I3 - 6	NO EDP A-42440-08 I3 - 8	NO EDP A-42440-10 I3 - 10	NO EDP A-42440-12 I3 - 12	NO EDP A-42440-14 I3 - 14	NO EDP A-42440-16 I3 - 16	NO EDP A-42440-18 I3 - 18	NO EDP A-42440-20 I3 - 20	NO EDP A-42440-22 I3 - 22	NO EDP A-42440-24 I3 - 24	PART NO. ENG NO. CKTS	NO EDP A-42440-02 I3 - 2	NO EDP A-42440-04 I3 - 4	NO EDP A-42440-06 I3 - 6	NO EDP A-42440-08 I3 - 8	NO EDP A-42440-10 I3 - 10	NO EDP A-42440-12 I3 - 12	NO EDP A-42440-14 I3 - 14	NO EDP A-42440-16 I3 - 16	NO EDP A-42440-18 I3 - 18	NO EDP A-42440-20 I3 - 20	NO EDP A-42440-22 I3 - 22	NO EDP A-42440-24 I3 - 24	I
H	NO EDP A-42440-02 I3 - 2	NO EDP A-42440-04 I3 - 4	NO EDP A-42440-06 I3 - 6	NO EDP A-42440-08 I3 - 8	NO EDP A-42440-10 I3 - 10	NO EDP A-42440-12 I3 - 12	NO EDP A-42440-14 I3 - 14	NO EDP A-42440-16 I3 - 16	NO EDP A-42440-18 I3 - 18	NO EDP A-42440-20 I3 - 20	NO EDP A-42440-22 I3 - 22	NO EDP A-42440-24 I3 - 24	NO EDP A-42440-02 I3 - 2	NO EDP A-42440-04 I3 - 4	NO EDP A-42440-06 I3 - 6	NO EDP A-42440-08 I3 - 8	NO EDP A-42440-10 I3 - 10	NO EDP A-42440-12 I3 - 12	NO EDP A-42440-14 I3 - 14	NO EDP A-42440-16 I3 - 16	NO EDP A-42440-18 I3 - 18	NO EDP A-42440-20 I3 - 20	NO EDP A-42440-22 I3 - 22	NO EDP A-42440-24 I3 - 24	H		
G	PLATING:	DRAINS:	PEGS:	MAT'L:	PACKAGING:	PLATING:	DRAINS:	PEGS:	MAT'L:	PACKAGING:	PLATING:	DRAINS:	PEGS:	MAT'L:	PACKAGING:	G											
F	ITEM NO. CKTS	- 2	- 4	- 6	- 8	- 10	- 12	- 14	- 16	- 18	- 20	- 22	- 24	ITEM NO. CKTS	- 2	- 4	- 6	- 8	- 10	- 12	- 14	- 16	- 18	- 20	- 22	- 24	F
E	- 2	- 4	- 6	- 8	- 10	- 12	- 14	- 16	- 18	- 20	- 22	- 24	- 2	- 4	- 6	- 8	- 10	- 12	- 14	- 16	- 18	- 20	- 22	- 24	E		
D	- 2	- 4	- 6	- 8	- 10	- 12	- 14	- 16	- 18	- 20	- 22	- 24	- 2	- 4	- 6	- 8	- 10	- 12	- 14	- 16	- 18	- 20	- 22	- 24	D		
C															C												
B															B												
A															A												

<b>STANDARDIZE NOTES</b> FCC NO: UCP2007-2152 DRW: NLSCHM1 DT 2007/03/12 CHKD: ADERR 2007/03/19 APPR: FSM TH 2007/03/19 REVISIONS	<b>QUALITY SYMBOLS</b> = 0.05 = 0.1	<b>GENERAL TOLERANCES (UNLESS SPECIFIED)</b>		<b>DIMENSION STYLE</b> IN/MM		SCALE ---	DESIGN UNITS METRIC	THIRD ANGLE PROJECTION			
		4 PLACES ± --- ± ---	3 PLACES ± --- ± ---	2 PLACES ± --- ± ---	1 PLACE ± --- ± ---	DRAWN BY ERH	DATE 2000/02/23	TITLE MINI-FIT B.M.I. VERTICAL HEADER ASSY WITH DRAIN HOLE OPTION			
		ANGULAR ±1/2°				CHECKED BY MB	DATE 2000/02/23	MOLEX INCORPORATED			
		DRAFT WHERE APPLICABLE MUST REMAIN WITHIN DIMENSIONS				APPROVED BY RE	DATE 2000/02/23	MATERIAL NO. SEE CHART	DOCUMENT NO. SDA-42440-****	SHEET NO. 5 OF 6	

	13	12	11	10	9	8	7	6	5	4	3	2	1
J	PLATING: TIN (SEE NOTE 2 OPTION 'S')			PLATING: TIN (SEE NOTE 2 OPTION 'S')			PLATING: 30 M.I. SELECT GOLD (SEE NOTE 2 OPTION 'GS')			PLATING: 30 M.I. SELECT GOLD (SEE NOTE 2 OPTION 'GS')			
	DRAINS: WITH DRAIN HOLES			DRAINS: WITH DRAIN HOLES			DRAINS: WITH DRAIN HOLES			DRAINS: WITH DRAIN HOLES			
	PEGS: WITH PEGS			PEGS: WITH PEGS			PEGS: WITH PEGS			PEGS: WITH PEGS			
	MAT'L: 94V-2 [NATURAL]			MAT'L: 94V-0 [NATURAL]			MAT'L: 94V-2 [NATURAL]			MAT'L: 94V-0 [NATURAL]			
PACKAGING: TUBE PER PK-40873-0151			PACKAGING: TUBE PER PK-40873-0151			PACKAGING: TUBE PER PK-40873-0151			PACKAGING: TUBE PER PK-40873-0151				
I	ITEM NO.		CKTS	ITEM NO.		CKTS	ITEM NO.		CKTS	ITEM NO.		CKTS	
	-	-	2	-	-	2	-	-	2	-	-	2	
	42440-3049	-	4	42440-3061	-	4	42440-3073	-	4	42440-3085	-	4	
	42440-3050	-	6	-	-	6	42440-3074	-	6	-	-	6	
	-	-	8	-	-	8	-	-	8	-	-	8	
	42440-3052	-	10	42440-3064	-	10	42440-3076	-	10	42440-3088	-	10	
	-	-	12	-	-	12	-	-	12	-	-	12	
	42440-3054	-	14	42440-3066	-	14	42440-3078	-	14	42440-3090	-	14	
	-	-	16	-	-	16	-	-	16	-	-	16	
	42440-3056	-	18	42440-3068	-	18	42440-3080	-	18	42440-3092	-	18	
H	-	-	20	-	-	20	-	-	20	-	-	20	
	-	-	22	-	-	22	-	-	22	-	-	22	
	42440-3059	-	24	42440-3071	-	24	42440-3083	-	24	42440-3095	-	24	
	-	-		-	-		-	-		-	-		
	-	-		-	-		-	-		-	-		
	-	-		-	-		-	-		-	-		
G	PLATING: 50 M.I. SELECT GOLD (SEE NOTE 2 OPTION 'GS3')			PLATING: 50 M.I. SELECT GOLD (SEE NOTE 2 OPTION 'GS3')			PLATING: 50 M.I. SELECT GOLD (SEE NOTE 2 OPTION 'GS3')			PLATING: 50 M.I. SELECT GOLD (SEE NOTE 2 OPTION 'GS3')			
	DRAINS: WITHOUT DRAIN HOLES			DRAINS: WITHOUT DRAIN HOLES			DRAINS: WITH DRAIN HOLES			DRAINS: WITH DRAIN HOLES			
	PEGS: WITH PEGS			PEGS: WITH PEGS			PEGS: WITH PEGS			PEGS: WITH PEGS			
	MAT'L: 94V-2 [NATURAL]			MAT'L: 94V-0 [NATURAL]			MAT'L: 94V-2 [NATURAL]			MAT'L: 94V-0 [NATURAL]			
PACKAGING: TUBE PER PK-40873-0151			PACKAGING: TUBE PER PK-40873-0151			PACKAGING: TUBE PER PK-40873-0151			PACKAGING: TUBE PER PK-40873-0151				
F	ITEM NO.		CKTS	ITEM NO.		CKTS	ITEM NO.		CKTS	ITEM NO.		CKTS	
	-	-	2	-	-	2	-	-	2	-	-	2	
	-	-	4	-	-	4	-	-	4	-	-	4	
	-	-	6	-	-	6	-	-	6	-	-	6	
	-	-	8	-	-	8	-	-	8	-	-	8	
	-	-	10	-	-	10	-	-	10	-	-	10	
	-	-	12	-	-	12	-	-	12	-	-	12	
	-	-	14	-	-	14	-	-	14	-	-	14	
	-	-	16	-	-	16	-	-	16	-	-	16	
	-	-	18	-	-	18	-	-	18	-	-	18	
E	-	-	20	-	-	20	-	-	20	-	-	20	
	-	-	22	-	-	22	-	-	22	-	-	22	
	-	-	24	-	-	24	-	-	24	-	-	24	
	-	-		-	-		-	-		-	-		
	-	-		-	-		-	-		-	-		
	-	-		-	-		-	-		-	-		
D	-	-		-	-		-	-		-	-		
	-	-		-	-		-	-		-	-		
	-	-		-	-		-	-		-	-		
	-	-		-	-		-	-		-	-		
	-	-		-	-		-	-		-	-		
	-	-		-	-		-	-		-	-		
	-	-		-	-		-	-		-	-		
	-	-		-	-		-	-		-	-		
	-	-		-	-		-	-		-	-		
	-	-		-	-		-	-		-	-		

STANDARDIZE NOTES FC NO: UCP2007-2152 2007/03/12 DRAWNLSCHMIDT CHKD:ADERR 2007/03/19 APPR:FSM TH 2007/03/19 REV DESCRIPTION	QUALITY SYMBOLS	GENERAL TOLERANCES (UNLESS SPECIFIED)	DIMENSION STYLE IN/MM	SCALE ---	DESIGN UNITS METRIC	THIRD ANGLE PROJECTION
	▽=0	4 PLACES ± --- ± ---	mm INCH	DRAWN BY ERH	DATE 2000/02/23	TITLE MINI-FIT B.M.I. VERTICAL HEADER ASSY WITH DRAIN HOLE OPTION
	▽=0	3 PLACES ± --- ± ---		CHECKED BY MB	DATE 2000/02/23	MOLEX INCORPORATED
		2 PLACES ± --- ± ---		APPROVED BY RE	DATE 2000/02/23	
	1 PLACE ± --- ± ---	ANGULAR ±1/2°		MATERIAL NO.	DOCUMENT NO.	SHEET NO.
		DRAFT WHERE APPLICABLE MUST REMAIN WITHIN DIMENSIONS	SEE CHART	SDA-42440-****		6 OF 6
				THIS DRAWING CONTAINS INFORMATION THAT IS PROPRIETARY TO MOLEX INCORPORATED AND SHOULD NOT BE USED WITHOUT WRITTEN PERMISSION		