

GDC

5 mm x 20 mm Time-delay glass tube fuses



Agency information

- cURus Recognition: Guide JDYX2/JDYX8, File E19180
- IMQ Approval: File E1921, CA03.00530
- MITI/JET: File JET1641-31003-1005

Ordering

- Specify packaging, product, and option code
- With TR2 packaging code, lead wire length is 19.05mm

Product features

- Time-delay, low breaking capacity
- Optional axial leads available
- 5 x 20mm physical size
- Glass tube, nickel-plated brass endcap construction
- Designed to IEC 60127-2 (32mA-10A)

Electrical Characteristics							
I_n	$2.1 I_n$ max	$2.75 I_n$		$4 I_n$		$10 I_n$	
		min	max	min	max	min	max
32mA-100mA	2 min	200 ms	10 sec	40 ms	3 sec	10 ms	300 ms
125mA-6.3A	2 min	600 ms	10 sec	150 ms	3 sec	20 ms	300 ms

Specifications								
Product Code	Voltage Rating Vac	Interrupting Rating (amps) at Rated Voltage (50Hz) Vac	Typical DC Cold Resistance (Ω)*	Typical Melting I ² t (amps)	Typical Voltage Drop (mV)‡	Agency Approvals		
						cURus	IMQ	MITI/JET
GDC-32mA	250	35	21.0	0.0051	1050	X	X	
GDC-40mA	250	35	13.90	0.0072	920	X	X	
GDC-50mA	250	35	9.24	0.0095	800	X	X	
GDC-63mA	250	35	6.96	0.021	760	X	X	
GDC-80mA	250	35	4.42	0.038	580	X	X	
GDC-100mA	250	35	2.80	0.045	490	X	X	
GDC-125mA	250	35	1.97	0.063	390	X	X	
GDC-160mA	250	35	1.27	0.093	320	X	X	
GDC-200mA	250	35	1.00	0.114	340	X	X	
GDC-250mA	250	35	0.640	0.265	270	X	X	
GDC-315mA	250	35	0.450	0.621	250	X	X	
GDC-400mA	250	35	0.31	0.872	210	X	X	
GDC-500mA	250	35	0.183	0.827	140	X	X	
GDC-630mA	250	35	0.186	1.33	150	X	X	
GDC-800mA	250	35	0.129	2.78	75	X	X	
GDC-1A	250	35	0.0757	6.45	87.5	X	X	X
GDC-1.25A	250	35	0.060	10.05	86	X	X	X
GDC-1.6A	250	35	0.0425	21.7	82	X	X	X
GDC-2A	250	35	0.03325	31.6	77	X	X	X
GDC-2.5A	250	35	0.0255	59.4	72.5	X	X	X
GDC-3.15A	250	35	0.0185	96.4	68.5	X	X	X
GDC-4A	250	40	0.0139	71.8	67	X	X	X
GDC-5A	250	50	0.00985	142.5	60.5	X	X	X
GDC-6.3A	250	63	0.0071	237.6	54	X	X	X

* DC Cold Resistance (measured at <10% of rated current)

‡ Typical Voltage Drop (voltage drop was measured at 20°C ambient temperature at rated current)

Dimensions - mm
Drawing Not to Scale

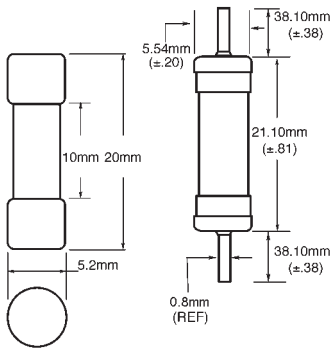

Nominal Time-Current Characteristics of GDC

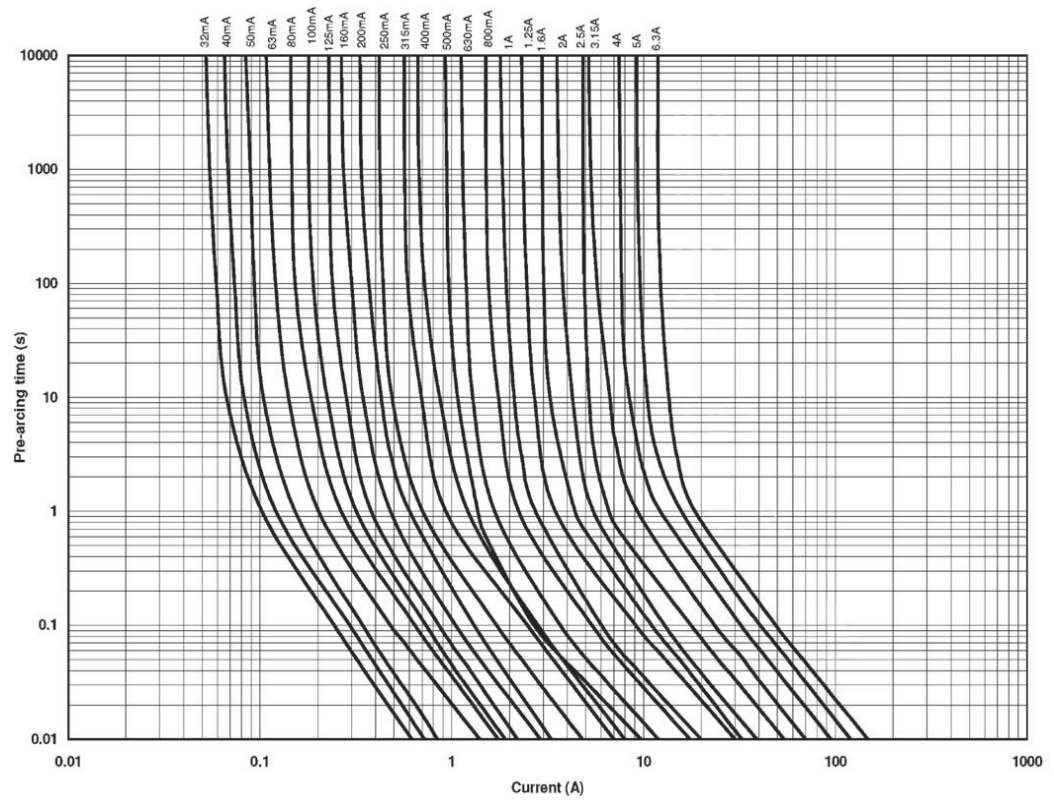

Packaging Code	
Packaging Code Suffix	Description
BK	100 fuses packed into a cardboard carton
BK1	1,000 fuses packed into a poly bag
TR2	1,500 fuses packed into tape on a reel (19.05mm lead wire length)

Option Code	
Option Code	Description
V	Axial leads - copper tinned wire with nickel plated brass endcaps

Life Support Policy: Eaton does not authorize the use of any of its products for use in life support devices or systems without the express written approval of an officer of the Company. Life support systems are devices which support or sustain life, and whose failure to perform, when properly used in accordance with instructions for use provided in the labeling, can be reasonably expected to result in significant injury to the user.

Eaton reserves the right, without notice, to change design or construction of any products and to discontinue or limit distribution of any products. Eaton also reserves the right to change or update, without notice, any technical information contained in this bulletin.

Eaton
Electronics Division
1000 Eaton Boulevard
Cleveland, OH 44122
United States
www.eaton.com/electronics

© 2017 Eaton
All Rights Reserved
Printed in USA
Publication No. 2016 BU-SB08382
May 2017

Eaton is a registered trademark.

All other trademarks are property of their respective owners.