

National Semiconductor is now part of
Texas Instruments.

Search <http://www.ti.com/> for the latest technical
information and details on our current products and services.



NATL SEMICOND (LINEAR)

T-58-11-13

LM79MXX Series 3-Terminal Negative Regulators

General Description

The LM79MXX series of 3-terminal regulators is available with fixed output voltages of $-5V$, $-8V$, $-12V$, and $-15V$. These devices need only one external component—a compensation capacitor at the output. The LM79MXX series is packaged in the TO-202 power package, TO-220 power package, and TO-39 metal can and is capable of supplying 0.5A of output current.

These regulators employ internal current limiting, safe area protection, and thermal shutdown for protection against virtually all overload conditions.

Low ground pin current of the LM79MXX series allows output voltage to be easily boosted above the preset value with a resistor divider. The low quiescent current of these devices with a specified maximum change with line and load ensures good regulation in the voltage boosted mode.

For output voltage other than $-5V$, $-8V$, $-12V$, and $-15V$ the LM137 series provides an output voltage range from $-1.2V$ to $-57V$.

Features

- Thermal, short circuit and safe area protection
- High ripple rejection
- 0.5A output current
- 4% tolerance on preset output voltage

Connection Diagrams

TO-202 Plastic Package (P)

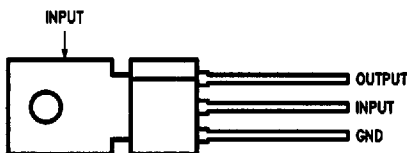

TL/H/10483-5

Front View

Order Number LM79M05CP, LM79M12CP or LM79M15CP
See NS Package Number P03A

TO-39 Metal Can Package (H)

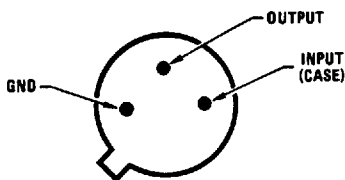

TL/H/10483-6

Bottom View

Order Number LM79M05CH, LM79M08CH,
LM79M12CH or LM79M15CH
See NS Package Number H03A

TO-220 Plastic Package (T)

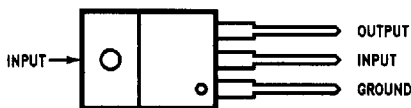

TL/H/10483-7

Front View

Order Number LM79M05CT, LM79M08CT,
LM79M12CT or LM79M15CT
See NS Package Number T03B

NATL SEMICON (LINEAR)

Absolute Maximum Ratings (Note 1)

If Military/Aerospace specified devices are required, please contact the National Semiconductor Sales Office/Distributors for availability and specifications.

Input Voltage
 $V_O = -5V$ -25V
 $V_O = -8V, -12V, -15V$ -35V

Input/Output Differential
 $V_O = -5V$ 25V
 $V_O = -8V, -12V, -15V$ 30V

Power Dissipation (Note 2) Internally Limited
 Operating Junction Temperature Range 0°C to $+125^\circ\text{C}$
 Storage Temperature Range -65°C to $+150^\circ\text{C}$
 Lead Temperature (Soldering, 10 sec.) 230°C
 ESD Susceptibility TBD

Electrical Characteristics LM79M05C, LM79M08C

Conditions unless otherwise noted: $I_{OUT} = 350\text{ mA}$, $C_{IN} = 2.2\ \mu\text{F}$, $C_{OUT} = 1\ \mu\text{F}$, $0^\circ\text{C} \leq T_J \leq +125^\circ\text{C}$

Part Number			LM79M05C			LM79M08C			Units
Output Voltage			-5V			-8V			
Input Voltage (Unless Otherwise Specified)			-10V			-14V			
Symbol	Parameter	Conditions	Min	Typ	Max	Min	Typ	Max	
V_O	Output Voltage	$T_J = 25^\circ\text{C}$	-4.8	-5.0	-5.2	-7.7	-8.0	-8.3	V
		$5\text{ mA} \leq I_{OUT} \leq 350\text{ mA}$	-4.75		-5.25	-7.6		-8.4	V
ΔV_O	Line Regulation	$T_J = 25^\circ\text{C}$ (Note 3)		8	50		5	80	mV
					($-25 \leq V_{IN} \leq -7$)		($-25 \leq V_{IN} \leq -10.5$)		
				2	30		3	50	mV
				($-18 \leq V_{IN} \leq -8$)		($-21 \leq V_{IN} \leq -11$)			
ΔV_O	Load Regulation	$T_J = 25^\circ\text{C}$, (Note 3) $5\text{ mA} \leq I_{OUT} \leq 0.5\text{A}$		30	100		30	160	mV
I_Q	Quiescent Current	$T_J = 25^\circ\text{C}$		1	2		1.5	3	mA
ΔI_Q	Quiescent Current Change	With Input Voltage			0.4			0.4	mA
		With Load, $5\text{ mA} \leq I_{OUT} \leq 350\text{ mA}$			($-25 \leq V_{IN} \leq -8$)		($-25 \leq V_{IN} \leq -10.5$)		0.4
V_n	Output Noise Voltage	$T_A = 25^\circ\text{C}$, $10\text{ Hz} \leq f \leq 100\text{ Hz}$		150			250		μV
			Ripple Rejection	$f = 120\text{ Hz}$	54	66		54	66
					($-18 \leq V_{IN} \leq -8$)		($-21 \leq V_{IN} \leq -11$)		
	Dropout Voltage	$T_J = 25^\circ\text{C}$, $I_{OUT} = 0.5\text{A}$		1.1			1.1		V
I_{OMAX}	Peak Output Current	$T_J = 25^\circ\text{C}$		800			800		mA
	Average Temperature Coefficient of Output Voltage	$I_{OUT} = 5\text{ mA}$, $0^\circ\text{C} \leq T_J \leq 100^\circ\text{C}$		-0.4			-0.6		$\text{mV}/^\circ\text{C}$

NATL SEMICON (LINEAR)

Electrical Characteristics LM79M12C, LM79M15C

Conditions unless otherwise noted: $I_{OUT} = 350 \text{ mA}$, $C_{IN} = 2.2 \mu\text{F}$, $C_{OUT} = 1 \mu\text{F}$, $0^\circ\text{C} \leq T_J \leq +125^\circ\text{C}$

LM79MXX Series

Part Number		LM79M12C			LM79M15C			Units				
Output Voltage		-12V			-15V							
Input Voltage (Unless Otherwise Specified)		-19V			-23V							
Symbol	Parameter	Conditions	Min	Typ	Max	Min	Typ	Max				
V_O	Output Voltage	$T_J = 25^\circ\text{C}$	-11.5	-12.0	-12.5	-14.4	-15.0	-15.6	V			
		$5 \text{ mA} \leq I_{OUT} \leq 350 \text{ mA}$	-11.4		-12.6	-14.25		-15.75	V			
									$(-27 \leq V_{IN} \leq -14.5)$		$(-30 \leq V_{IN} \leq -10.5)$	
ΔV_O	Line Regulation	$T_J = 25^\circ\text{C}$ (Note 3)		5	80		5	80	mV			
											$(-30 \leq V_{IN} \leq -14.5)$	$(-30 \leq V_{IN} \leq -17.5)$
									3	50	3	50
										$(-25 \leq V_{IN} \leq -15)$	$(-28 \leq V_{IN} \leq -18)$	
ΔV_O	Load Regulation	$T_J = 25^\circ\text{C}$, (Note 3) $5 \text{ mA} \leq I_{OUT} \leq 0.5 \text{ A}$		30	240		30	240	mV			
I_Q	Quiescent Current	$T_J = 25^\circ\text{C}$		1.5	3		1.5	3	mA			
ΔI_Q	Quiescent Current Change	With Input Voltage			0.4			0.4	mA			
		With Load, $5 \text{ mA} \leq I_{OUT} \leq 350 \text{ mA}$						0.4	mA			
V_n	Output Noise Voltage	$T_A = 25^\circ\text{C}$, $10 \text{ Hz} \leq f \leq 100 \text{ Hz}$		400			400	μV				
	Ripple Rejection	$f = 120 \text{ Hz}$	54	70		54	70	dB				
									$(-25 \leq V_{IN} \leq -15)$	$(-30 \leq V_{IN} \leq -17.5)$		
	Dropout Voltage	$T_J = 25^\circ\text{C}$, $I_{OUT} = 0.5 \text{ A}$		1.1			1.1	V				
I_{OMAX}	Peak Output Current	$T_J = 25^\circ\text{C}$		800			800	mA				
	Average Temperature Coefficient of Output Voltage	$I_{OUT} = 5 \text{ mA}$, $0^\circ\text{C} \leq T_J \leq 100^\circ\text{C}$		-0.8			-1.0	$\text{mV}/^\circ\text{C}$				

Note 1: Absolute Maximum Ratings indicate limits beyond which damage to the device may occur. Operating Ratings indicate conditions for which the device is intended to be functional, but do not guarantee specific performance limits. For guaranteed specifications and test conditions, see the Electrical Characteristics.

Note 2: Refer to Typical Performance Characteristics and Design Considerations for details.

Note 3: Regulation is measured at a constant junction temperature by pulse testing with a low duty cycle. Changes in output voltage due to heating effects must be taken into account.

1

Typical Performance Characteristics

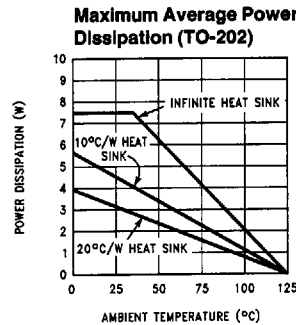
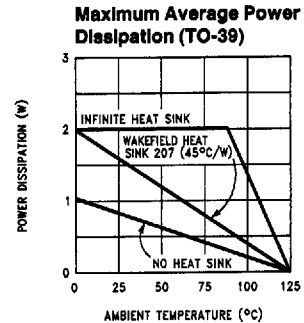
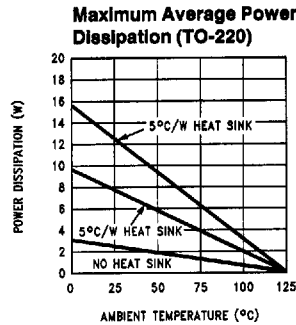
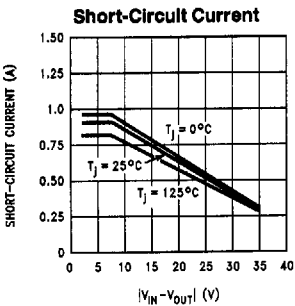
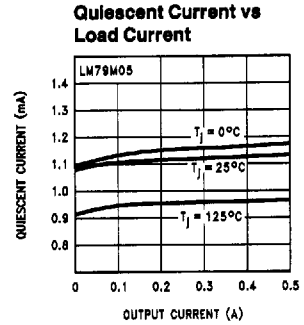
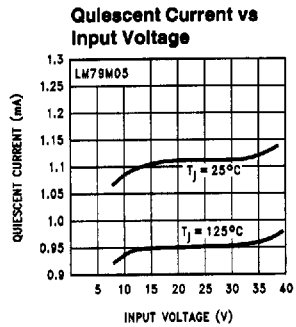
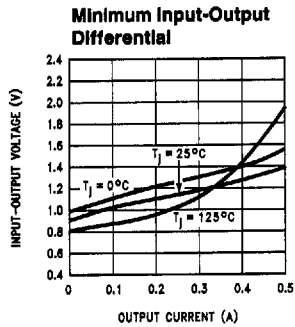
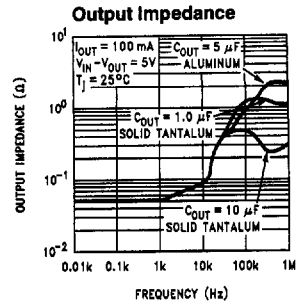
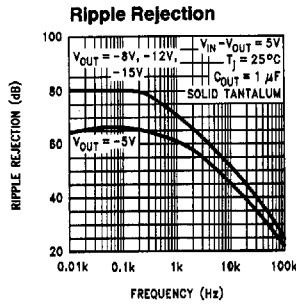
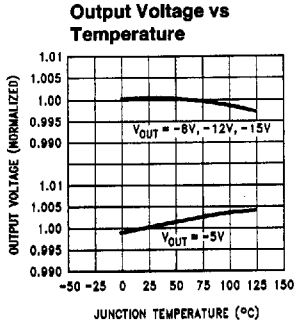

Schematic Diagrams

NATL SEMICOND (LINEAR)

-5V

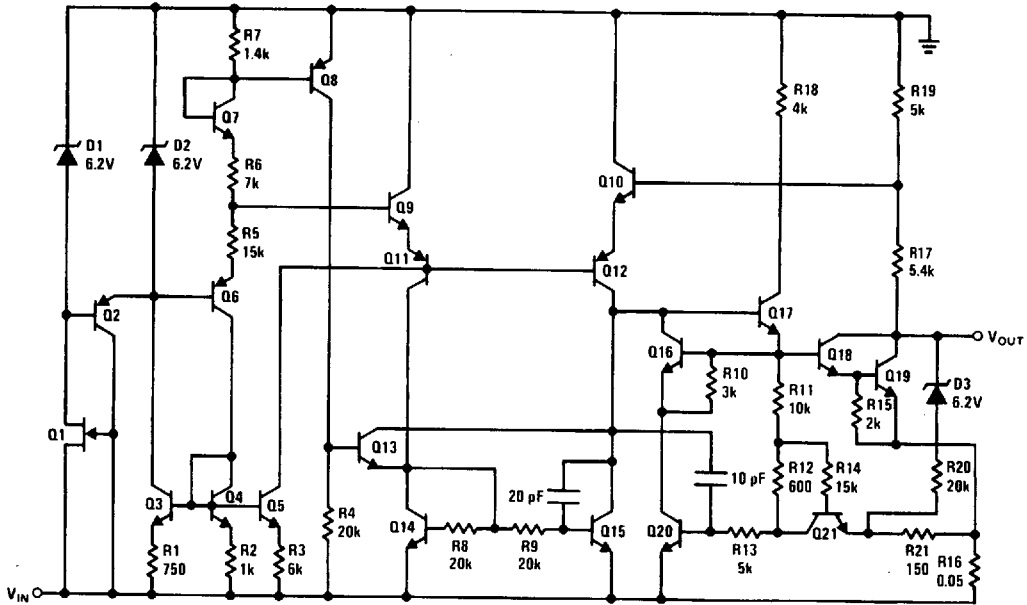

TL/H/10483-8

-8V, -12V and -15V

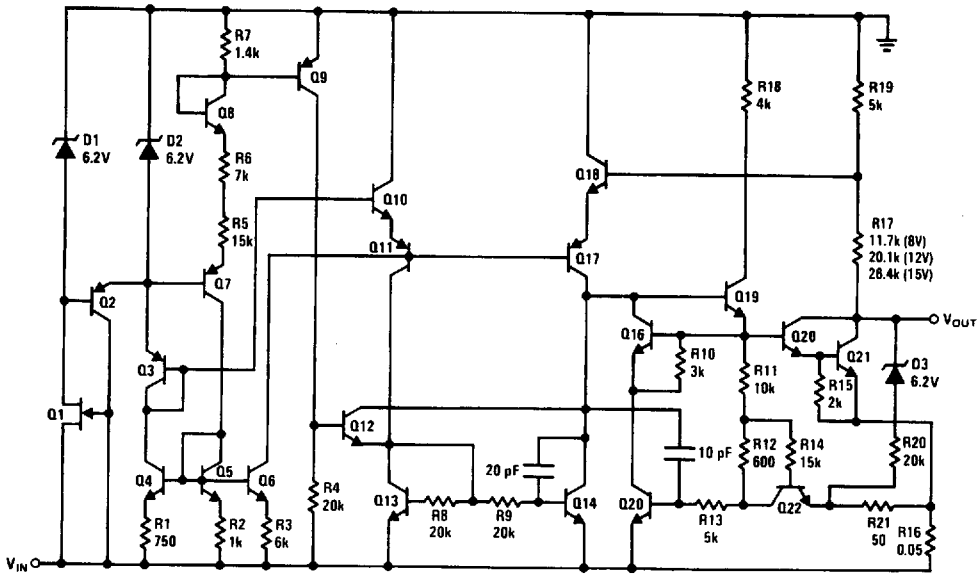

TL/H/10483-9

Design Considerations

The LM79MXX fixed voltage regulator series have thermal-overload protection from excessive power, internal short-circuit protection which limits the circuit's maximum current, and output transistor safe-area compensation for reducing the output current as the voltage across the pass transistor is increased.

Although the internal power dissipation is limited, the junction temperature must be kept below the maximum specified temperature in order to meet data sheet specifications. To calculate the maximum junction temperature or heat sink required, the following thermal resistance values should be used:

Package	θ_{JC} (°C/W)	θ_{JA} (°C/W)
TO-39	18	120
TO-202	12	70
TO-220	3	40

$$P_{DMAX} = \frac{T_{JMAX} - T_A}{\theta_{JC} + \theta_{CA}} \text{ or} \quad (1)$$

$$= \frac{T_{JMAX} - T_A}{\theta_{JA}} \text{ (Without a Heat Sink)}$$

$$\theta_{CA} = \theta_{CS} + \theta_{SA}$$

Solving for T_J :

$$T_J = T_A + P_D (\theta_{JC} + \theta_{CA}) \text{ or}$$

$$= T_A + P_D \theta_{JA} \text{ (Without a Heat Sink)}$$

Where

- T_J = Junction Temperature
- T_A = Ambient Temperature
- P_D = Power Dissipation
- θ_{JC} = Junction-to-Case Thermal Resistance
- θ_{CA} = Case-to-Ambient Thermal Resistance
- θ_{CS} = Case-to-Heat Sink Thermal Resistance
- θ_{SA} = Heat Sink-to-Ambient Thermal Resistance
- θ_{JA} = Junction-to-Ambient Thermal Resistance

Typical Applications

Bypass capacitors are necessary for stable operation of the LM79MXX series of regulators over the input voltage and output current ranges. Output bypass capacitors will improve the transient response of the regulator.

The bypass capacitors (2.2 μF on the input, 1.0 μF on the output), should be ceramic or solid tantalum which have good high frequency characteristics. If aluminum electrolytics are used, their values should be 10 μF or larger. The bypass capacitors should be mounted with the shortest leads, and if possible, directly across the regulator terminals.

Fixed Regulator

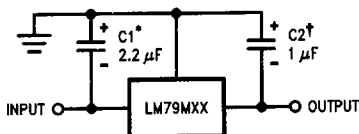

TL/H/10483-2

*Required if regulator is separated from filter capacitor by more than 3". For value given, capacitor must be solid tantalum. 25 μF aluminum electrolytic may be substituted.

†Required for stability. For value given, capacitor must be solid tantalum. 25 μF aluminum electrolytic may be substituted. Values given may be increased without limit.

For output capacitance in excess of 100 μF , a high current diode from input to output (1N4001, etc.) will protect the regulator from momentary input shorts.

Variable Output

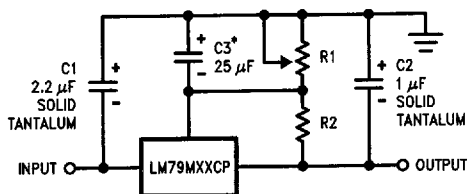

TL/H/10483-3

*Improves transient response and ripple rejection. Do not increase beyond 50 μF .

$$V_{OUT} = V_{SET} \left(\frac{R1 + R2}{R2} \right)$$

Select R2 as follows:

LM79M05C	300 Ω
LM79M08C	500 Ω
LM79M12C	750 Ω
LM79M15C	1k

NATL SEMICON (LINEAR)

Typical Applications (Continued)

NATL SEMICOND (LINEAR)

± 15V, 1 Amp Tracking Regulators

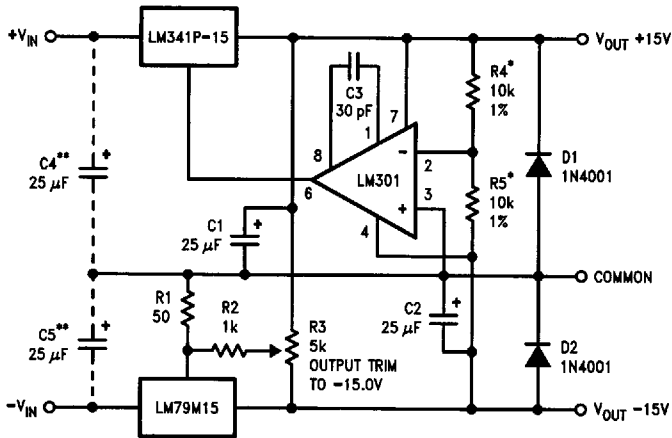

TL/H/10483-1

Performance (Typical)

Load Regulation at 0.5A
 Output Ripple, $C_{IN} = 3000 \mu F, I_L = 0.5A$
 Temperature Stability
 Output Noise $10 \text{ Hz} \leq f \leq 10 \text{ kHz}$

	(- 15)	(+ 15)
Load Regulation at 0.5A	40 mV	2 mV
Output Ripple, $C_{IN} = 3000 \mu F, I_L = 0.5A$	100 μV_{rms}	100 μV_{rms}
Temperature Stability	50 mV	50 mV
Output Noise $10 \text{ Hz} \leq f \leq 10 \text{ kHz}$	150 μV_{rms}	150 μV_{rms}

*Resistor tolerance of R4 and R5 determine matching of (+) and (-) outputs.

**Necessary only if raw supply filter capacitors are more than 3" from regulators.

Dual Trimmed Supply

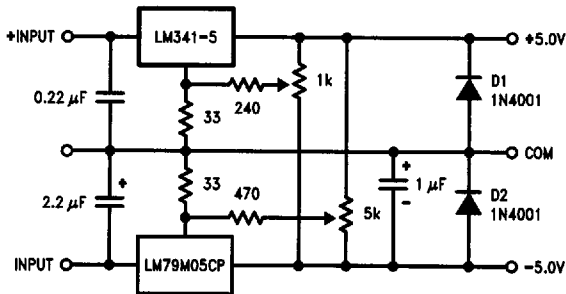

TL/H/10483-4