

REVISIONS					
REV	ECO	DESCRIPTION	DATE	BY	APPR
B1	-	RELEASED DRAWING	Nov-23-2014	Ben	Tommy
B2	-	VOLTAGE UPDATE AND ADD KEY ICON	Dec-25-2020	Ronald	Tommy

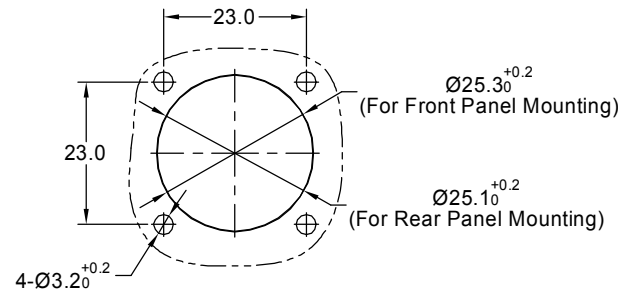
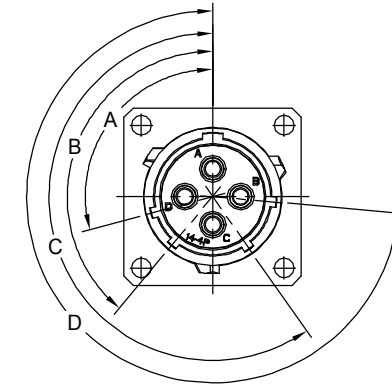
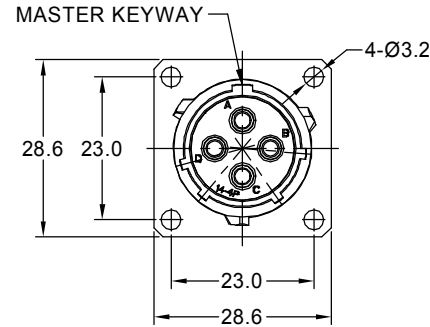
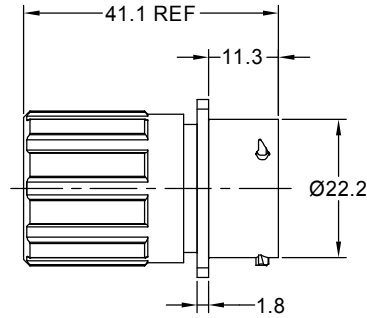

PANEL CUT OUT REFERENCE

KEY POS	PART NUMBER					
	-40°C ~ 105°C	-40°C ~ 125°C	A	B	C	D
N	RT00144PNHEC	RT00144PNHEC03	105°	140°	215°	265°
W	RT00144PWHEC	RT00144PWHEC03	60°	140°	215°	265°
X	RT00144PXHEC	RT00144PXHEC03	105°	160°	215°	265°
Y	RT00144PYHEC	RT00144PYHEC03	105°	140°	225°	265°
Z	RT00144PZHEC	RT00144PZHEC03	105°	140°	215°	295°

NOTES : (UNLESS OTHERWISE SPECIFIED)

- MATERIAL :
SHELL : ZINC ALLOY , NICKEL PLATED.
INSERT : THERMOPLASTIC , UL94 V-0.
END CAP : THERMOPLASTIC , UL94 V-0.
PLASTIC BUSHING : THERMOPLASTIC , UL94 V-0.
SEAL GASKET : NBR/SILICONE RUBBER.
O-RING : NBR/SILICONE RUBBER.
WIRE SEAL : SILICONE RUBBER.
- SPECIFICATIONS :
2.1 RATED CURRENT : 23A (MAX).
2.2 RATED VOLTAGE : 500V (AC/DC) .
2.3 OPERATING TEMPERATURE : SEE CHART.
2.4 DIELECTRIC WITHSTANDING VOLTAGE : LESS THAN 2 MILLIAMPS CURRENT LEAKAGE@2000 VOLTS AC.
2.5 INSULATION RESISTANCE : 5000 MEGOHMS MIN.
2.6 IP--CLASS : IP67 (MATED CONDITION).
2.7 MATING CYCLES DURABILITY : 500 CYCLES MIN.
2.8 ROHS COMPLIANT.
- SUITABLE CONTACTS : 2.5mm CONTACTS.
- ALL DIMENSIONS ARE FOR REFERENCE USE ONLY.
- CONTACT SIZE AND REAR SEAL WIRE RANGE :

CONTACT SIZE	MIN. INSUL O.D.	MAX. INSUL O.D.	WIRE RANGE
2.5mm	Ø3.3mm	Ø4.3mm	14 - 12AWG

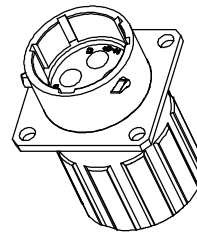

QUANTITY	SEE PART NUMBER CHART	PART NUMBER	DESCRIPTION	ITEM								
MATERIALS LIST												
UNLESS OTHERWISE SPECIFIED		SIGNATURES	DATE	 Sine Systems - www.amphenol-sine.com 44724 Morley Drive Clinton Township, MI 48036								
1) All dimensions are in metric(mm).		DRAWN: Ronald	Dec-25-20									
2) Tolerances are as follows: 1 PL DEC ±0.30 2 PL DEC ±0.15 3 PL DEC ±0.08		CHECKED: Flan	Dec-26-20									
3) Note reference =		ENGINEER:										
MATERIAL SPECIFICATIONS:		APPROVAL: Tommy	Dec-27-2020	ECOMATE RM,RECEPTACLE, SIZE 14,4POS,PIN,END CAP.								
PROCESS SPECIFICATIONS:		CUSTOMER:										
NEXT ASSY:		THIS DRAWING IS SUPPLIED FOR INFORMATION ONLY. DESIGN FEATURES, SPECIFICATIONS AND PERFORMANCE DATA SHOWN HEREON ARE THE PROPERTY OF THE AMPHENOL CORPORATION. NO RIGHTS OF REPRODUCTION ARE IMPLIED. ALL DIMENSIONS ARE SUBJECT TO NORMAL MANUFACTURING VARIATIONS.										
		<table border="1"> <tr> <td>SIZE</td> <td>TYPE</td> <td>DWG NO:</td> <td>REVISION</td> </tr> <tr> <td>B</td> <td>C-</td> <td>RT00144P*HEC</td> <td>B2</td> </tr> </table>		SIZE	TYPE	DWG NO:	REVISION	B	C-	RT00144P*HEC	B2	
SIZE	TYPE	DWG NO:	REVISION									
B	C-	RT00144P*HEC	B2									
		SCALE: NONE		SHEET 1 OF 1								

TITLE: ECOMATE RM,RECEPTACLE,SIZE 14,4POS,PIN,END CAP.
 DWG NO: RT00144P*HEC
 REV: B2
 SH: 1
 OF: 1