

THIS DRAWING IS UNPUBLISHED. RELEASED FOR PUBLICATION 2011
 © COPYRIGHT 2011 TE CONNECTIVITY ALL RIGHTS RESERVED.

LOC	DIST	REVISIONS					
B	-	P	LTR	DESCRIPTION	DATE	DWN	APVD
			D	ECR-11-018847	13/09/11	JB	MG
			E	ECR-13-008169	29/05/13	MJG	DP

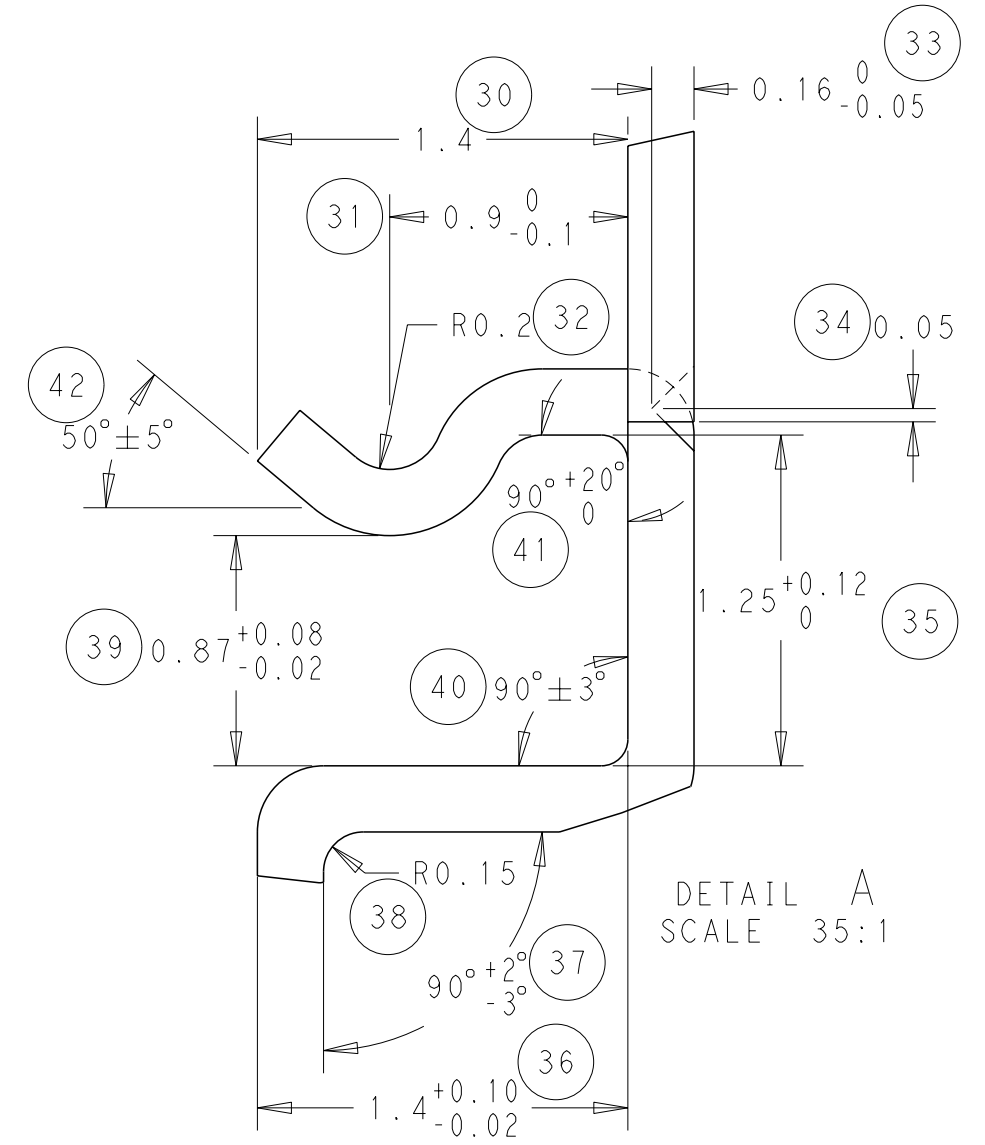

NOTE
 BOWING: AFTER UPPER TIE BAR REMOVAL - 1.5mm MAX. FOR 500mm
 PITCH: AFTER UPPER TIE BAR REMOVAL - 2.54±0.127

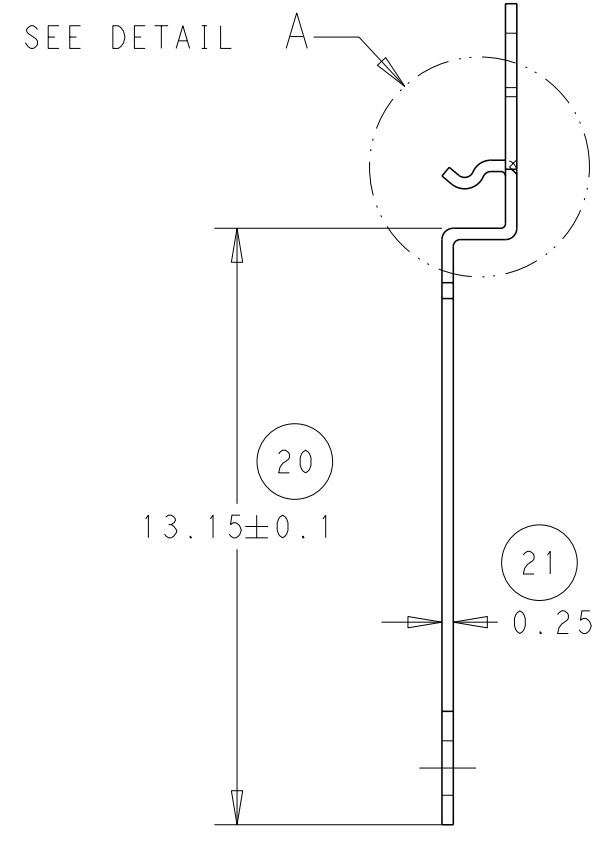
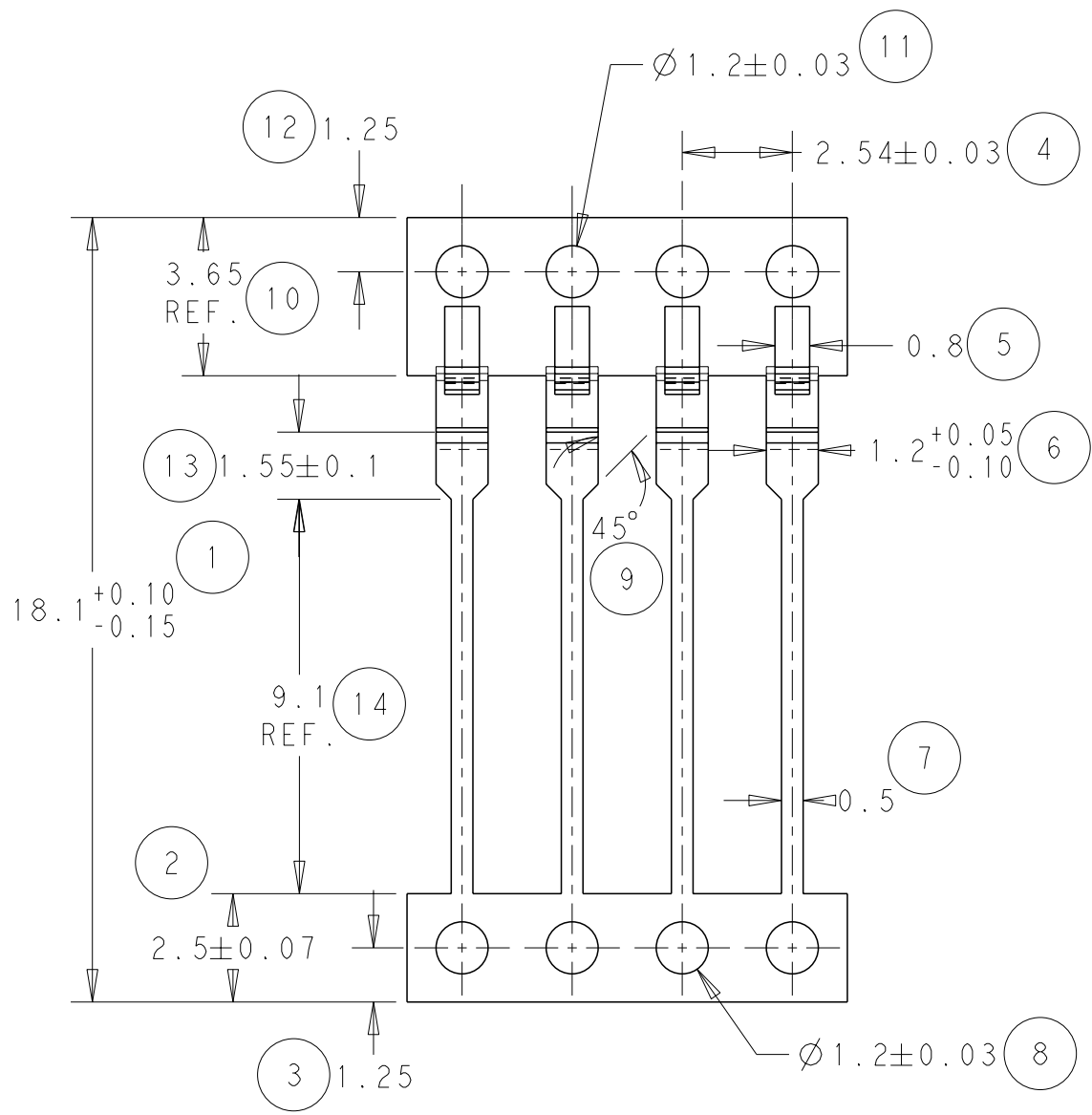
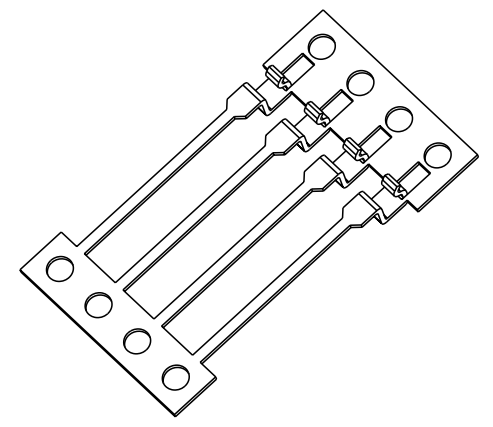

SCALE 3:1

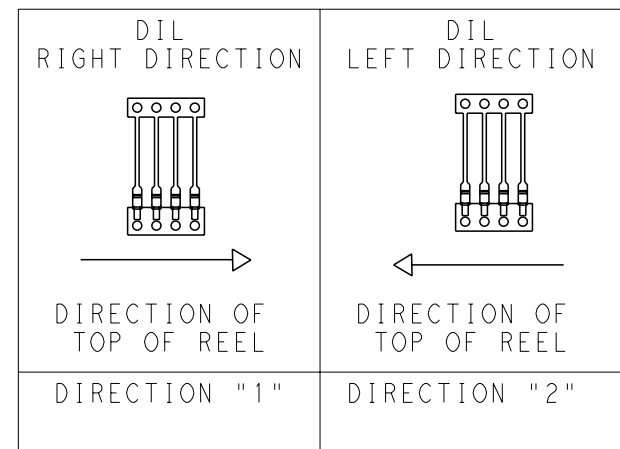

THIS DRAWING IS A CONTROLLED DOCUMENT.

DIMENSIONS:	TOLERANCES UNLESS OTHERWISE SPECIFIED:
mm	0 PLC ±-
	1 PLC ±-
	2 PLC ±0.05
	3 PLC ±-
	4 PLC ±-
	ANGLES ±0.5
MATERIAL	FINISH -
SEE ABOVE.	

DWN	J. BRIGHT	12/09/11
CHK	M. GREENER	12/09/11
APVD	D. PENNINGTON	12/09/11
PRODUCT SPEC	-	
APPLICATION SPEC	-	
WEIGHT	-	

2	Ni & Sn	1544443-4
2	Sn	1544443-3
1	Ni & Sn	1544443-2
1	Sn	1544443-1
REELING	FINISH	PART NUMBER



NAME				DIL CONTACT	
SIZE	CAGE CODE	DRAWING NO	RESTRICTED TO		
A300779	C=1544443				
CUSTOMER DRAWING		SCALE	SHEET	OF	REV
		NTS	1	1	E