

THIS DRAWING IS UNPUBLISHED. RELEASED FOR PUBLICATION
 © COPYRIGHT BY TYCO ELECTRONICS CORPORATION. ALL RIGHTS RESERVED.

LOC	DIST	REVISIONS			
P	LTR	DESCRIPTION	DATE	DWN	APVD
AJ	16	A	REVISED PER EC 0514-0150-05	09NOV2005	REH GM

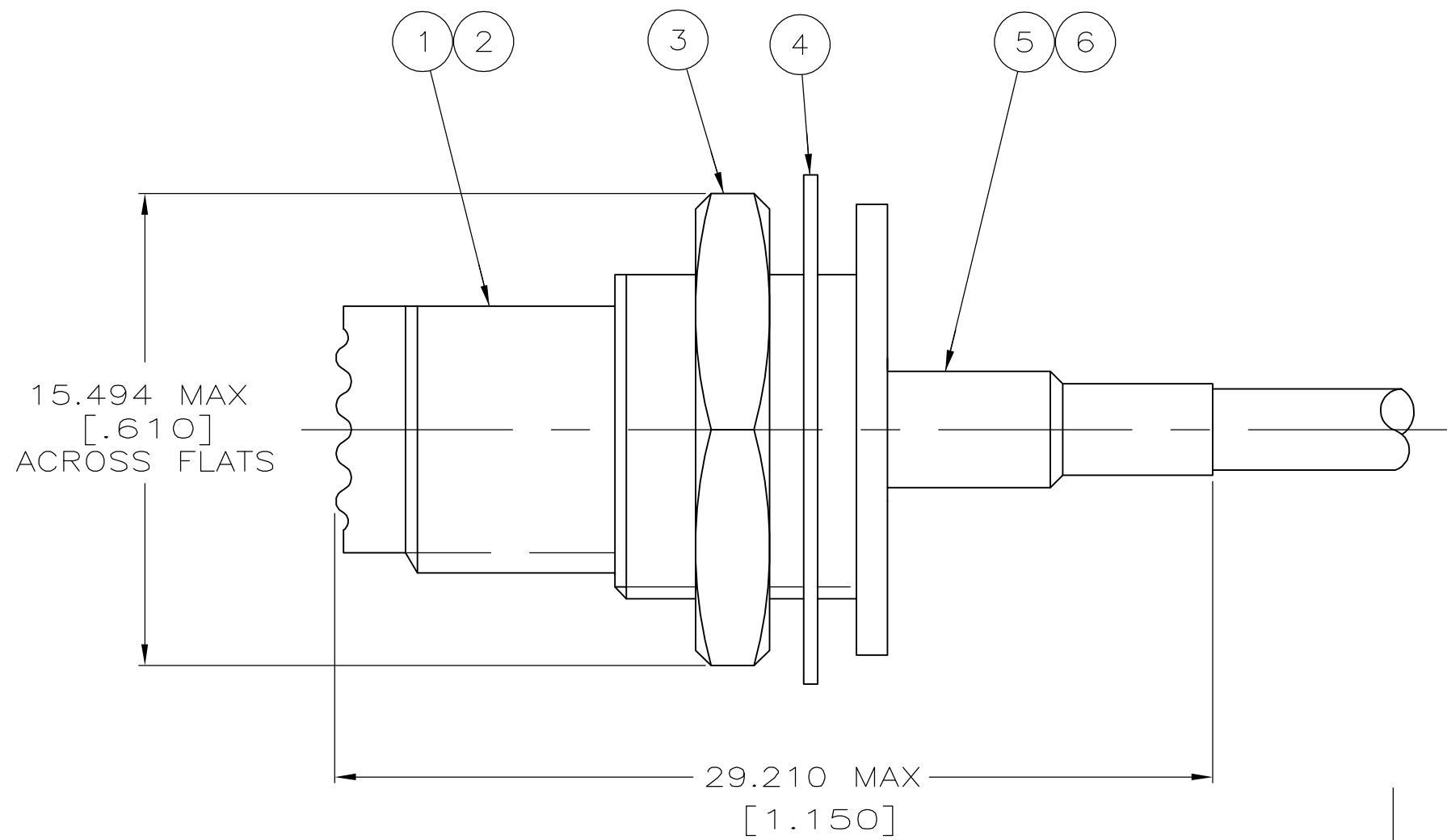

△ USE CRIMP TOOL: 220149-1

- 2. 2.540 [.100] MAX PANEL THICKNESS
- 3. PACKAGED UNASSEMBLED

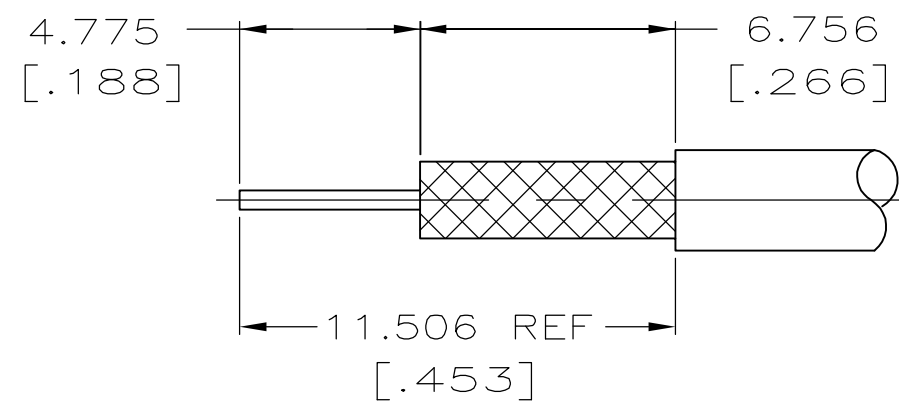

RECOMMENDED STRIP LENGTH

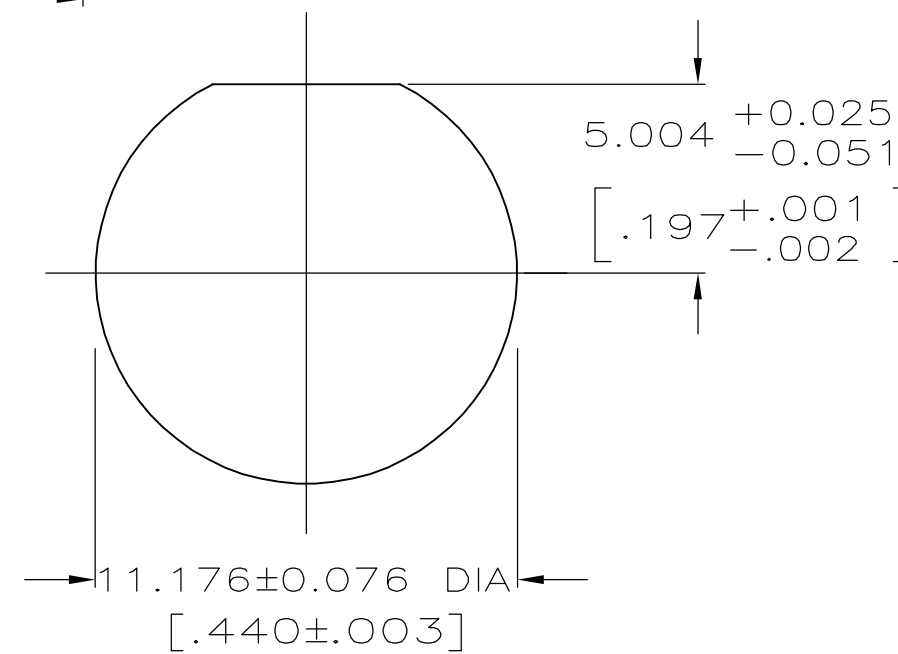

RECOMMENDED PANEL CUTOUT

△ RG-58/U	228906-1	226599-2	980506-1	228575-2	226610-2	9-228905-0	5414045-1
FOR USE WITH CABLE	⑦ GASKET QTY=1	⑤ FERRULE QTY=1	④ LOCKWASHER QTY=1	③ JAM NUT QTY=1	② CONTACT QTY=1	① JACK, BULKHEAD QTY=1	PART NUMBER

THIS DRAWING IS A CONTROLLED DOCUMENT.		DWN A. FERNANDEZ-DOCK5 22APR2005	Tyco Electronics Corporation Harrisburg, PA 17105-3608	
DIMENSIONS: mm [INCHES]		CHK J. HAVENER 22APR2005		
TOLERANCES UNLESS OTHERWISE SPECIFIED:		APVD G. MICHAEL 22APR2005	NAME JACK, BULKHEAD, MINIATURE UHF	
0 PLC ± - 1 PLC ± - 2 PLC ± - 3 PLC ± 0.406 [.016] 4 PLC ± - ANGLES ± - FINISH -		PRODUCT SPEC -	SIZE A2	CAGE CODE 00779
MATERIAL -		WEIGHT -	DRAWING NO C=5414045	RESTRICTED TO -
CUSTOMER DRAWING			SCALE 5:1	SHEET 1 of 1