

THIS DRAWING IS UNPUBLISHED. RELEASED FOR PUBLICATION. ALL INTERNATIONAL RIGHTS RESERVED.

PART NUMBER	REV	FIRST USED
1852130-1	B	122500-1
1852130-2	B	565435-5
1852130-3	B	354500-1

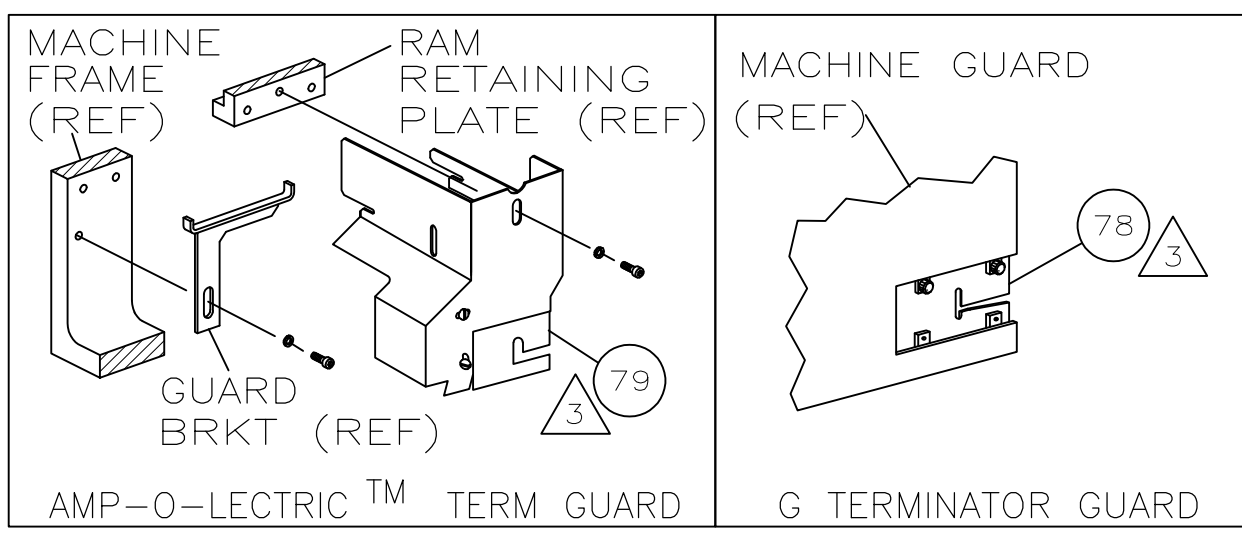

TERMINAL NAME: TERMINAL, MALE, '56 SERIES					
AMP TERM PN	MFR TERM PN	PACKARD TERMINAL	PACKARD CRIMP SPECS		
1572802	2965439				
		PAD LTR	CRIMP HEIGHT	WIRE SIZE	
		A	2.05 ±0.05 [.081 ±.002IN]	0.8mm ² OR 18	
		B	2 ±0.05 [.079 ±.002IN]	0.5mm ²	
		C	NOT	USED	
		D	NOT	USED	
		CRIMP	SIZE	TYPE	RANGE
		WIRE	2.89 [.114 IN]	F	0.5-0.8mm ² OR 18
		INSUL	3.94 [.155 IN]	F	2.95-3.13[.116-.123 IN]
WIRE STRIP LENGTH	TERM APPL SPEC	FEED	APPL INSTRUCTION	SET UP GAGE	LAYOUT
4.22-4.98	NONE	15.87	408-8040	458637-1	L4013

LOC	DIST	REVISIONS					
A	66	F	LTR	DESCRIPTION	DATE	DWN	APVD
		B		ECR-09-013446	6-2009	MY	GB

-1	LEADMAKER	AIRFEED
-2	BENCH MODEL K	AIRFEED
-3	BENCH MODEL G	AIRFEED

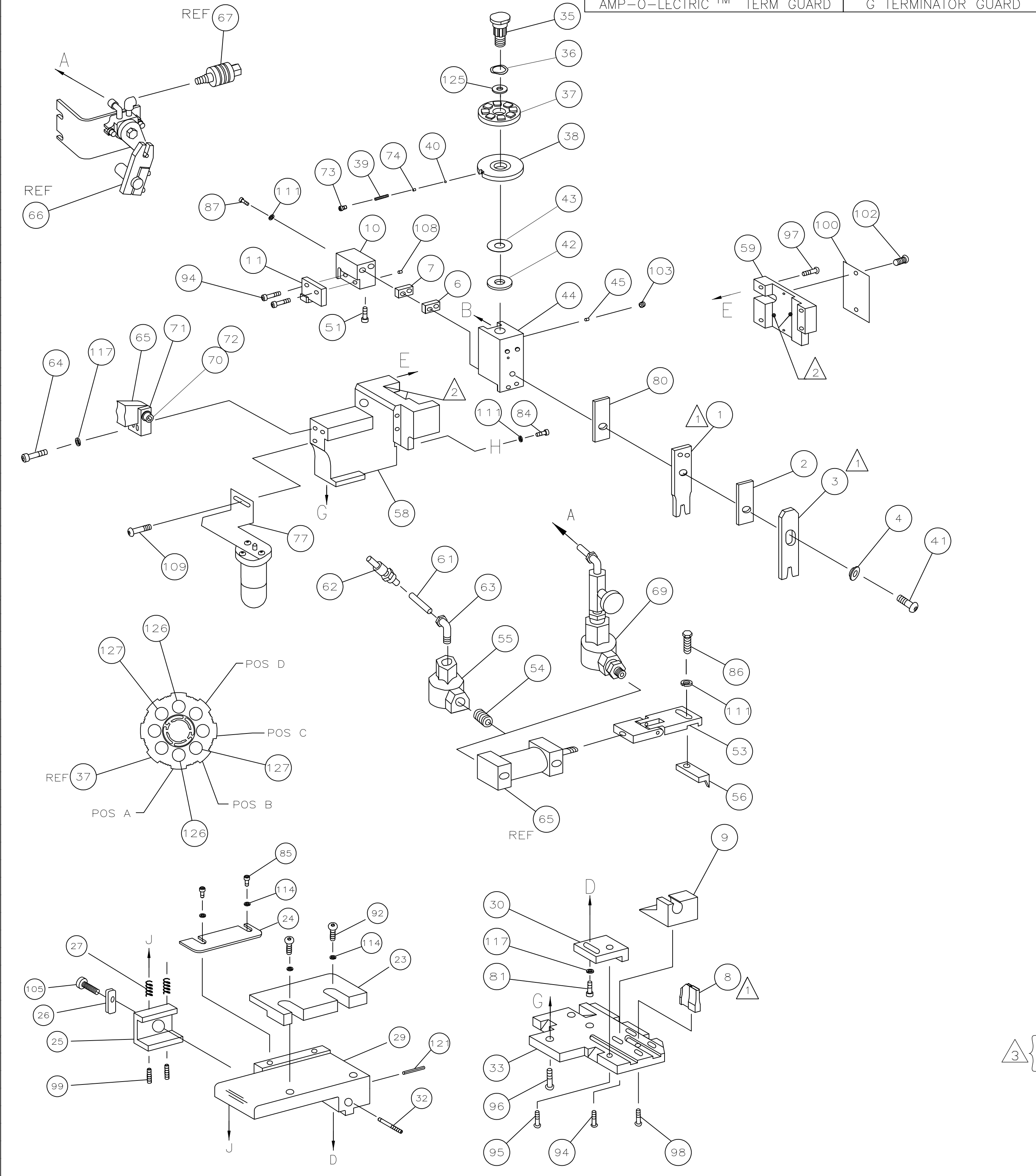

QTY	REQD	PER	ASSY	PART NO	DESCRIPTION	ITEM NO
						129
						128
2	2	2	-	8-354778-5	PIN, WIRE DISC (.2920)B	127
2	2	2	-	8-354778-1	PIN, WIRE DISC (.2900)A	126
1	1	1	-	986950-1	WASHER, FLAT PRECISION	125
1	1	1	-	217238-1	GENERAL INSTRUCTION PACKAGE	124
1	1	1	-	4088040	SF APPL INST 408-8040	123
						122
1	1	1	-	3-21028-8	PIN,SLT SPR(Ø.093x.62)ST GDE PL	121
						120
						119
						118
1	1	1	-	21024-5	WASHER, LOCK(#10)ADJ BLOCK	117
						116
						115
4	4	4	-	21024-2	WASHER,LOCK(#4)FRONT STP GUIDE	114
						113
						112
4	4	4	-	21024-4	WASHER,LOCK(#8)STRIPPER	111
						110
-	1	-	-	2-21002-6	SCR,BHC(10-32x.38)LUBE ASSY	109
1	1	1	-	2-21006-1	SCR, SKT SET(4-40x.25)	108
						107
						106
1	1	1	-	22353-8	SCR,SHLD(Ø.187x.25)DRAG LEVER	105
						104
1	1	1	-	21009-2	SCR,SKT SET(1/4-20x.25 LW)RAM	103
2	2	2	-	21017-2	SCR,DRIVE(#2x.19)ID PLATE	102
						101
1	1	1	-	461264-1	PLATE, IDENTIFICATION	100
2	2	2	-	5-21006-6	SCR,SKT SET (10-32x.75)DRAG	99
1	1	1	-	22733-8	SCR,BHC(8-32x.38 LW)ANVIL	98
4	4	4	-	2-21002-9	SCR,BHC(10-32x.75)CAP	97
3	3	3	-	2-22733-8	SCR,BHC(1/4-20x.62)HOUSING	96
1	1	1	-	2-21002-7	SCR,BHC(10-32x.50)SG ADJ BLK	95
4	4	4	-	2-21002-2	SCR,BHC(8-32x.50)TERM H DWN	94
						93
2	2	2	-	1-21000-5	SCR,SHC(4-40x.50)F ST GUIDE	92
						91
						90
						89
						88
2	2	2	-	3-21000-1	SCR,SHC(8-32x1.00)DEP-HOLD	87
1	1	1	-	2-22603-0	SCR,HEX HD(8-32x.31)FEED FINGER	86
2	2	2	-	1-21000-3	SCR,SHC(4-40x.25)R ST GUIDE	85
1	1	1	-	2-21000-7	SCR,SHC(8-32x.50)STRIPPER	84
						83
						82
1	1	1	-	3-21000-4	SCR,SHC(10-32x.38)SG ADJ BL	81
1	1	1	-	455888-6	SPACER, CRIMPER	80
-	REF	-	-	455749-1	GUARD, WINDOW	79
REF	-	-	-	679532-1	INSERT, GUARD	78
-	1	-	-	1-465184-0	LUBRICATOR ASSY	77
						76
						75
1	1	1	-	690603-1	SPRING, ASSIST	74
1	1	1	-	23030-1	SCR,SHC(6-32x.25 SL)INS DISC	73
1	1	1	-	3-21001-5	SCR,SHC(3/8-16x1.00)AIR FEED	72
1	1	1	-	459610-1	MOUNT, FEED BRACKET	71
-3	-2	-1	U/M	PART NO	DESCRIPTION	ITEM NO

QTY	REQD	PER	ASSY	PART NO	DESCRIPTION	ITEM NO
						70
1	1	1	-	21024-8	WASHER, LOCK 3/8	69
-	1	-	-	692655-5	AIR FEED VALVE ASSY	68
						67
-	REF	-	-	24042-2	VALVE, SHUT OFF	66
-	REF	-	-	692655-6	AIR FEED VALVE ASSY	65
1	1	1	-	461065-1	AIR FEED ASSY (1 INCH)	64
2	2	2	-	3-21000-8	SCR,SHC(10-32x.88)AIR ASSY	63
1	-	1	-	980285-2	ELBOW, SWIVEL 1/8 NPT - 1/4 T	62
1	-	1	-	23238-1	QUICK DISCONNECT	61
21.00	-	21.00	IN	27319-4	TUBING, POLY-FLO Ø.25	60
						59
1	1	1	-	454220-1	CAP, RAM	58
1	1	1	-	454485-1	HOUSING	57
						56
1	1	1	-	3-694433-9	PAWL, FEED	55
1	-	1	-	22374-7	VALVE, QUICK EXHAUST	54
1	-	1	-	22304-1	NIPPLE, HEX	53
1	1	1	-	461062-1	FEED FINGER ASSY	52
						51
1	1	1	-	811242-8	BUMPER, HOLDDOWN	50
						49
						48
						47
						46
						45
1	1	1	-	690191-1	PLUG, NYLON	44
1	1	1	-	455673-1	RAM	43
1	1	1	-	690125-1	WASHER, LAMINATED	42
1	1	1	-	690124-1	WASHER, RAM	41
1	1	1	-	7-21002-9	BOLT, CRIMPER(5/16x1.00)	40
1	1	1	-	23241-6	BALL, STEEL	39
1	1	1	-	690170-1	SPRING, COMPRESSION	38
1	1	1	-	690142-1	DISC, INSULATION	37
1	1	1	-	354777-1	WIRE DISC, PLASTIC	36
1	1	1	-	22480-5	WASHER, SPRING	35
1	1	1	-	690212-1	POST, RAM	34
						33
1	1	1	-	1633145-1	PLATE, BASE	32
1	1	1	-	690432-3	SCREW, ADJUSTMENT	31
						30
1	1	1	-	455689-1	BLOCK, STRIP GUIDE ADJ	29
1	1	1	-	2-844048-3	PLATE, STRIP GUIDE	28
						27
2	2	2	-	1-22284-0	SPRING, DRAG	26
1	1	1	-	240793-1	LEVER, DRAG RELEASE	25
1	1	1	-	240792-1	DRAG, TERMINAL	24
1	1	1	-	1-690438-0	GUIDE, STRIP (REAR)	23
1	1	1	-	1-189124-4	GUIDE, STRIP (FRONT)	22
						21
						20
1	1	1	-	1-456468-1	STRIPPER	19
						18
						17
						16
						15
						14
						13
						12
1	1	1	-	1725849-2	BLADE, SLUG	11
1	1	1	-	1583893-3	HOLDER, SLUG BLADE	10
1	1	1	-	1213905-2	SHEAR, LOWER	9
1	1	1	-	3-1424534-9	ANVIL	8
1	1	1	-	5-240641-2	SPACER, DEPRESSOR (REAR)	7
1	1	1	-	240641-2	SPACER, DEPRESSOR (REAR)	6
						5
1	1	1	-	238009-8	SPACER, BLOCK CRIMPER	4
1	1	1	-	7-456134-0	CRIMPER, INSULATION	3
1	1	1	-	455888-3	SPACER, CRIMPER	2
1	1	1	-	2-1633305-9	CRIMPER, WIRE	1
-3	-2	-1	U/M	PART NO	DESCRIPTION	ITEM NO

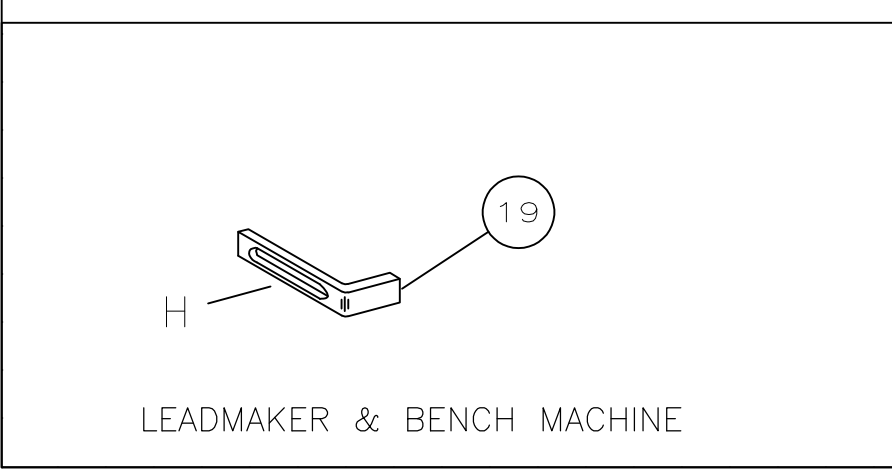

- 1 RECOMMENDED SPARE PARTS.
- 2 GREASE LIGHTLY.
- 3 GUARD MUST BE IN PLACE WHEN OPERATING APPLICATOR IN A BENCH MACHINE.
- 4 SEE DRAWING FOR COMPONENTS.

THIS DRAWING IS A CONTROLLED DOCUMENT.

DIMENSIONS: INCHES	TOLERANCES UNLESS OTHERWISE SPECIFIED:	APPROVED: T. ELBIN	NAME: T. ELBIN	PRODUCT SPEC: -	APPLICATION SPEC: -	SIZE: A1	CAGE CODE: 00779	DRAWING NO: 1852130	RESTRICTED TO: -
MATERIAL: -	FINISH: -	WEIGHT: -	SCALE: -	SHEET: 1 of 1	REV: B	CUSTOMER DRAWING			

Tyco Electronics Corporation, Harrisburg, PA 17105-3608