

PART NUMBER	REVISION	DESCRIPTION	FEED TYPE
2150530-1	C	FINE CRIMP HEIGHT ADJUST	MECHANICAL
2150530-2	C	FINE CRIMP HEIGHT ADJUST	PNEUMATIC
7-2150530-1	C	MECHANICAL AND CRIMP TOOLING KIT	MECHANICAL
7-2150530-2	C	PNEUMATIC AND CRIMP TOOLING KIT	PNEUMATIC
7-2150530-7	A	CRIMP TOOLING KIT	-

ATLANTIC VERSION TERMINATOR INTERFACE ADAPTER

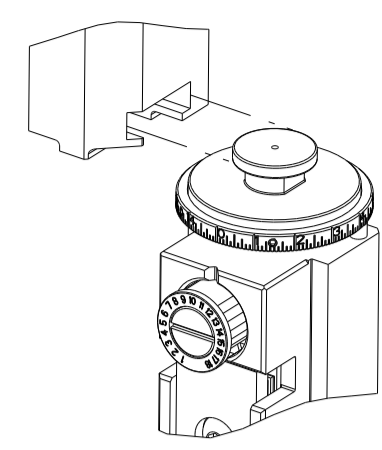

APPLICATOR DATA		
CRIMP	SIZE	TYPE
WIRE	1.02 mm [.040]	F
INSUL	-	-
APPL INSTRUCTIONS 408-35043		

TERMINAL DATA: TE TERMINAL		TE CRIMP SPECIFICATION	
TERMINAL NAME: SOLDER SPLICE			
WIRE STRIP LENGTH		INSULATION DIAMETER RANGE	
4.40-5.00 mm [.173-.197 IN]		∅	-
TERMINAL APPLICATION SPECIFICATION		160725	
TERMINALS APPLIED			
TE TERMINAL	TE TERMINAL	TE TERMINAL	TE TERMINAL
160725-1			

WIRE SIZE	CRIMP HEIGHT mm [INCH]	CRIMP HEIGHT REFERENCE SETTING
22 AWG OR 0.32mm2	1.25+/-0.05 [.049+/-0.002]	8.7
24 AWG	1.07+/-0.05 [.042+/-0.002]	10.5
26 AWG	1.00+/-0.05 [.039+/-0.002]	11.2

- RECOMMENDED SPARE PARTS
- REFER TO SUPPLIED INSTRUCTION SHEET FOR CLEANING, LUBRICATION AND STORAGE OF APPLICATOR.
- CRIMP HEIGHT REFERENCE SETTING WAS THE SETTING USED WHEN THE APPLICATOR WAS QUALIFIED AT THE FACTORY. ADJUSTMENT MAY BE NECESSARY WHEN RUNNING APPLICATOR IN THE FIELD.
- TERMINAL LUBRICANT IS RECOMMENDED.
- 5. UNLESS SPECIFIED OTHERWISE TORQUE VALUES SHALL BE USED PER DOCUMENT, 101-35000.
- REFER TO CUSTOMER DRAWING 160725 FOR CRIMP SPECIFICATION FRONT AND REAR BELLMOUT IS PERMITTED.

***WARNING**
ON INSTALLATION, SET WIRE DISC TO CRIMP HEIGHT REFERENCE SETTING FOR LARGEST WIRE SIZE. CRIMP HEIGHT REFERENCE SETTINGS GREATER THAN THE VALUE SHOWN MAY CAUSE DAMAGE TO THE CRIMP TOOLING. REFER TO THE INSTRUCTION SHEET FOR PROPER SETUP AND ADJUSTMENTS.

ATLANTIC VERSION
Shown on sheets 1 of 4 & 2 of 4
(Pacific version shown on sheets 3 of 4 & 4 of 4)

LOC	DIST	REVISIONS					
A	66	P	LTN	DESCRIPTION	DATE	DWN	APVD
		A		RELEASED	27APR2015	KH	UG
		A1		ECR-22-135300	07APR2022	FJ	TE
		B		ECR-22-136592	20APR2022	JWC	ROY
		C		ECR-22-140366	25MAY2022	FZ	JAH

-	1	-	1	-	2119641-1	FEED CAM, AIR FEED	248	
-	-	1	-	1	2119580-1	MECHANICAL FEED ASSEMBLY	239	
-	1	-	1	-	2844940-3	AIR FEED MODULE	238	
-	REF	REF	REF	REF	994970-2	COUNTER, MAGNETIC	164	
-	1	1	1	1	2119955-2	ASSY, LUBRICATOR, END FEED	84	
-	1	1	1	1	455888-8	SPACER, CRIMPER	82	
-	1	1	1	1	1803607-4	DOCUMENTATION PACKAGE	71	
-	2	2	2	2	2-18032-2	SCR, SET, FLT PNT, M3 X 10.0	70	
-	1	1	1	1	2119740-1	TAG, IDENTIFICATION	67	
-	2	2	2	2	2168078-1	SCREW, DRIVE, RH, RoHS, 2 x .188	66	
-	2	2	2	2	2168400-8	SHCS, LOW HEAD, RoHS, M4 X 16	64	
-	1	1	1	1	5-18022-5	SCR, HEX HD CAP, M4 X 6.0	59	
-	-	1	-	1	2063961-1	FEED FINGER	58	
-	3	3	3	3	2168400-4	SHCS, LOW HEAD, RoHS, M4 X 8	57	
-	2	2	2	2	5018030-1	NUT, HEX, REG, RoHS, M3	54	
-	2	2	2	2	986965-8	NUT, LOCK, HEX, TORQUE (M4)	53	
-	1	-	1	-	2063961-1	FEED FINGER	51	
-	1	2	1	2	18023-9	SCR, SKT HD CAP M4 X 6.0	49	
-	-	1	-	1	2119652-1	FEED CAM, PRE FEED	48	
-	-	1	-	1	2119653-1	FEED CAM, POST FEED	47	
-	1	1	1	1	2119655-5	APPLICATOR BASIC ASSEMBLY, EF	46	
-	1	1	1	1	1803517-2	RAM ASSEMBLY, EF ATLANTIC	44	
-	1	1	1	1	2-18024-7	SCR, BTN SKT HD CAP (M8 X 30.0)	41	
-	7	7	7	7	1-18028-2	WASHER, FLAT, REG M4	33	
-	2	2	2	2	2168083-9	SCR, SKT HD CAP, RoHS, M4 X 20	31	
-	2	2	2	2	1-2168083-0	SCR, SKT HD CAP, RoHS, M4 X 10	29	
-	1	1	1	1	240639-7	STRIPPER (MACHINING)	27	
-	2	2	2	2	1-2168083-5	SCR, SKT HD CAP, RoHS, M4 X 30	25	
-	1	1	1	1	1752371-1	PLATE, STRIP GUIDE	24	
-	1	1	1	1	240825-6	PLATE, STRIP HOLD DOWN	23	
-	2	2	2	2	2-22281-3	SPRING, COMPRESSION	22	
-	1	1	1	1	1752373-4	DRAG	20	
-	2	2	2	2	1901259-1	GUIDE, LOWER STRIP	18	
-	4	4	4	4	1-2079383-1	SCR, BHSC, RoHS (M6 X 12)	17	
-	1	1	1	1	240644-1	PLATE, REAR SHEAR	11	
-	2	2	2	2	240645-3	SPACER, SHEAR PLATE	10	
-	1	1	1	1	690619-4	PLATE, RETAINING	9	
-	1	2	2	1	1803131-3	ANVIL, SPLICE TYPE	8	
-	1	1	1	1	459722-3	BLADE, SHEAR	7	
-	-	-	-	-	-	-	5	
-	-	-	-	-	-	-	4	
-	-	-	-	-	-	-	3	
-	-	-	-	-	-	-	2	
-	1	2	2	1	1803232-1	CRIMPER, WIRE F	1	
-	77	72	71	2	-1	PART NO	DESCRIPTION	ITEM NO

DIMENSIONS:		TOLERANCES UNLESS OTHERWISE SPECIFIED:		MATERIAL:		FINISH:	
mm	0 PLC ±	1 PLC ±	2 PLC ±	3 PLC ±	4 PLC ±	ANGLES	FINISH
MATERIAL:				WEIGHT:		SCALE:	
-				-		1:1	

LOC		DIST		REVISIONS			
A		66		REV	DATE	BY	APPV
-				SEE SHEET 1	-	-	-

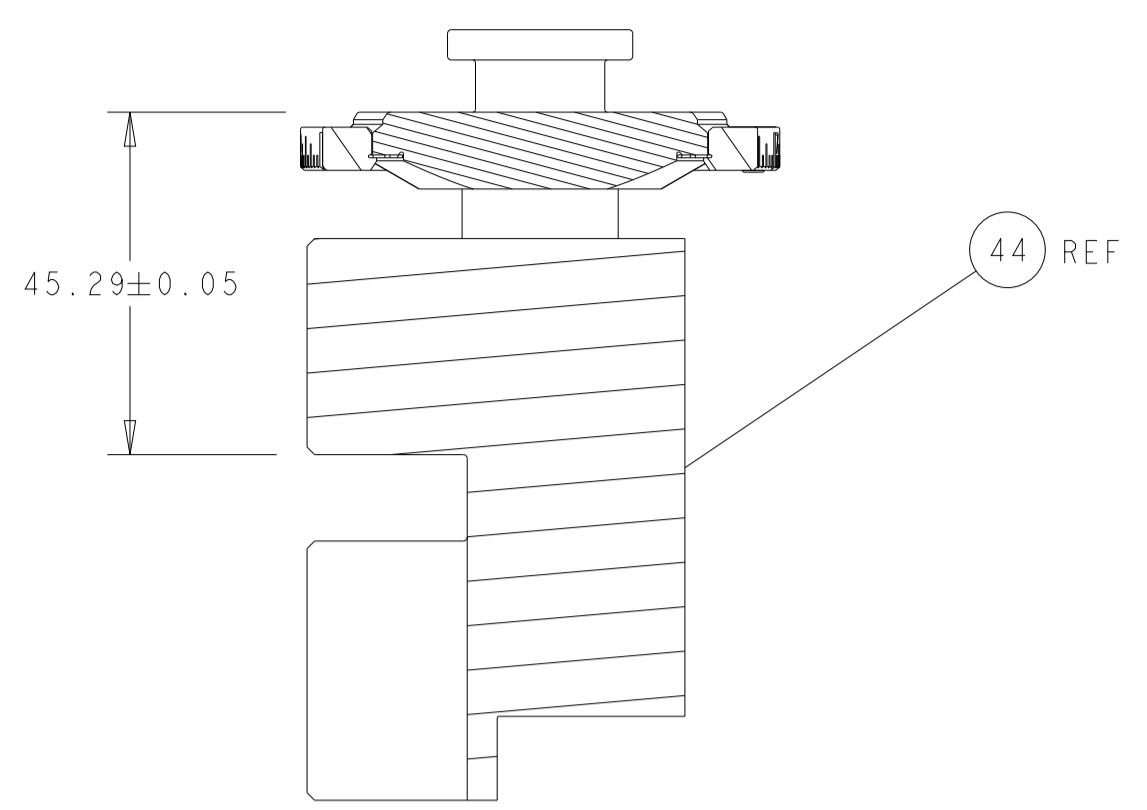

RAM SET-UP

FEED TYPE
MECHANICAL

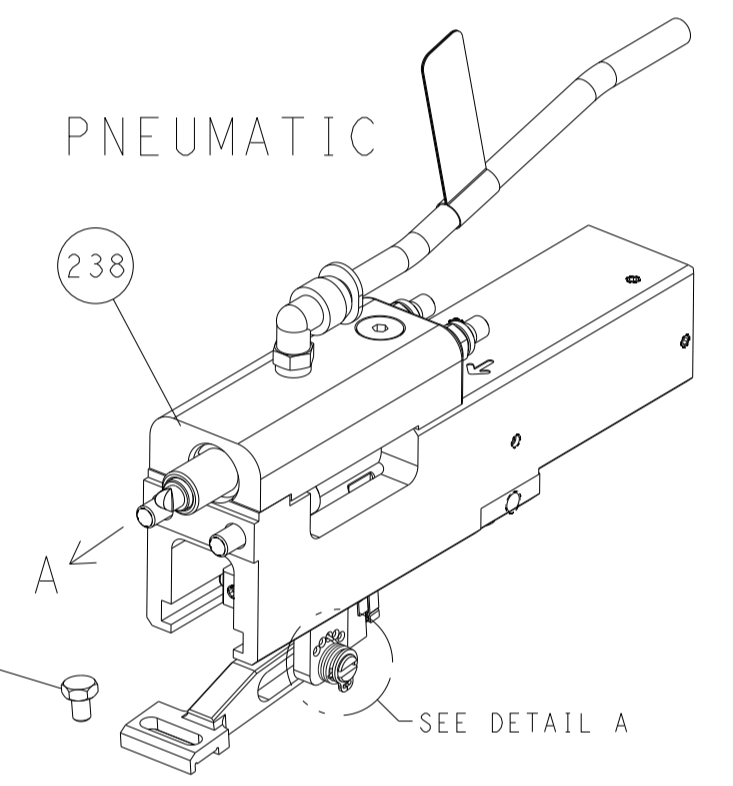
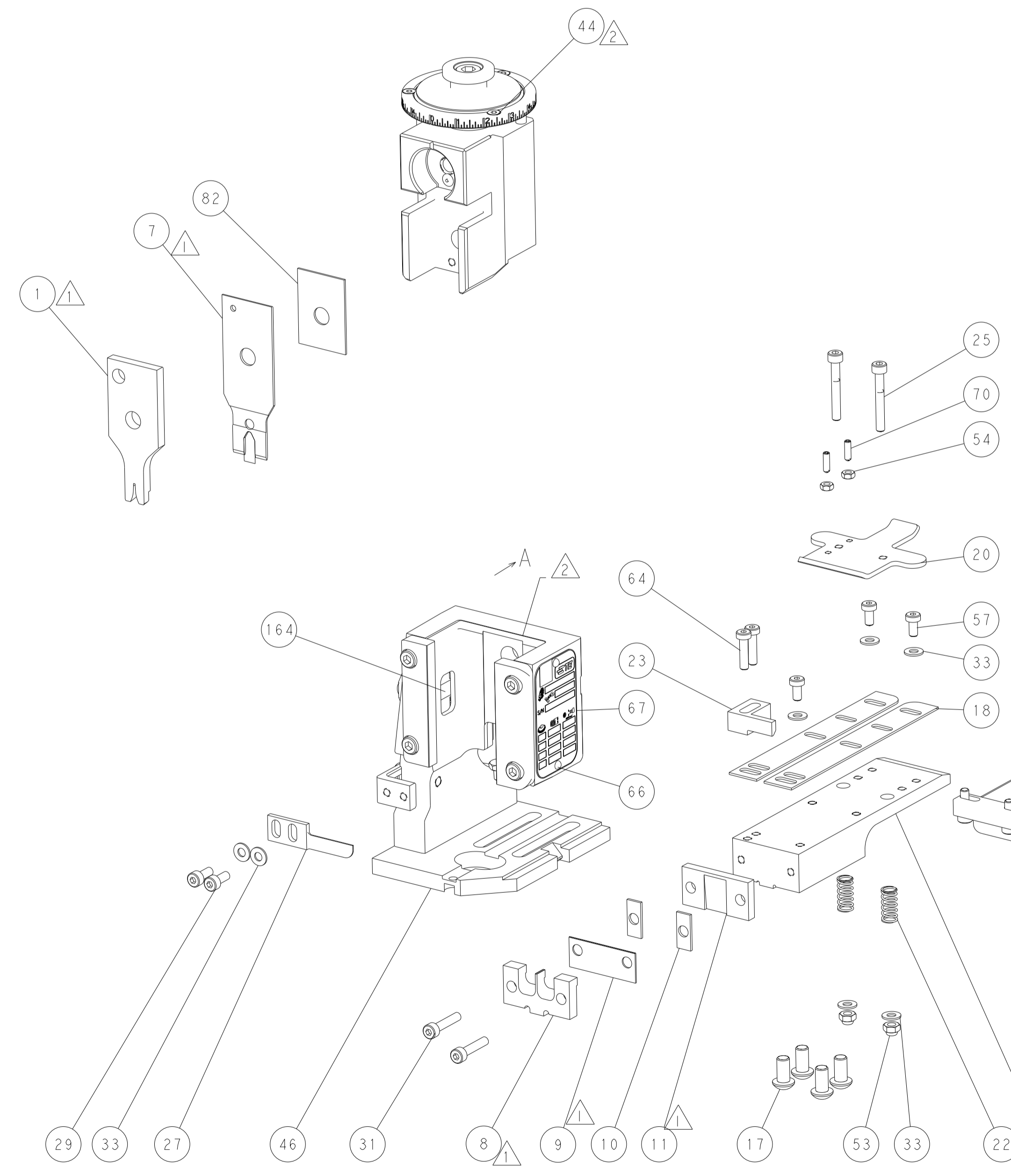
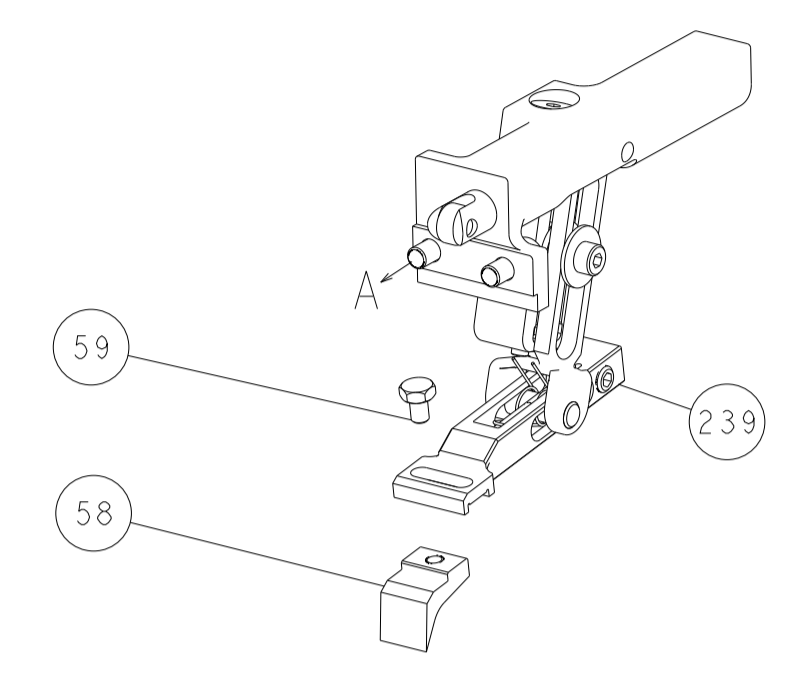

PNEUMATIC

FEED SPRING
SETTING POSITION

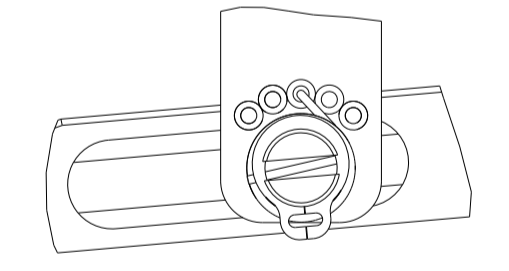

DETAIL A

CAM POSITIONS

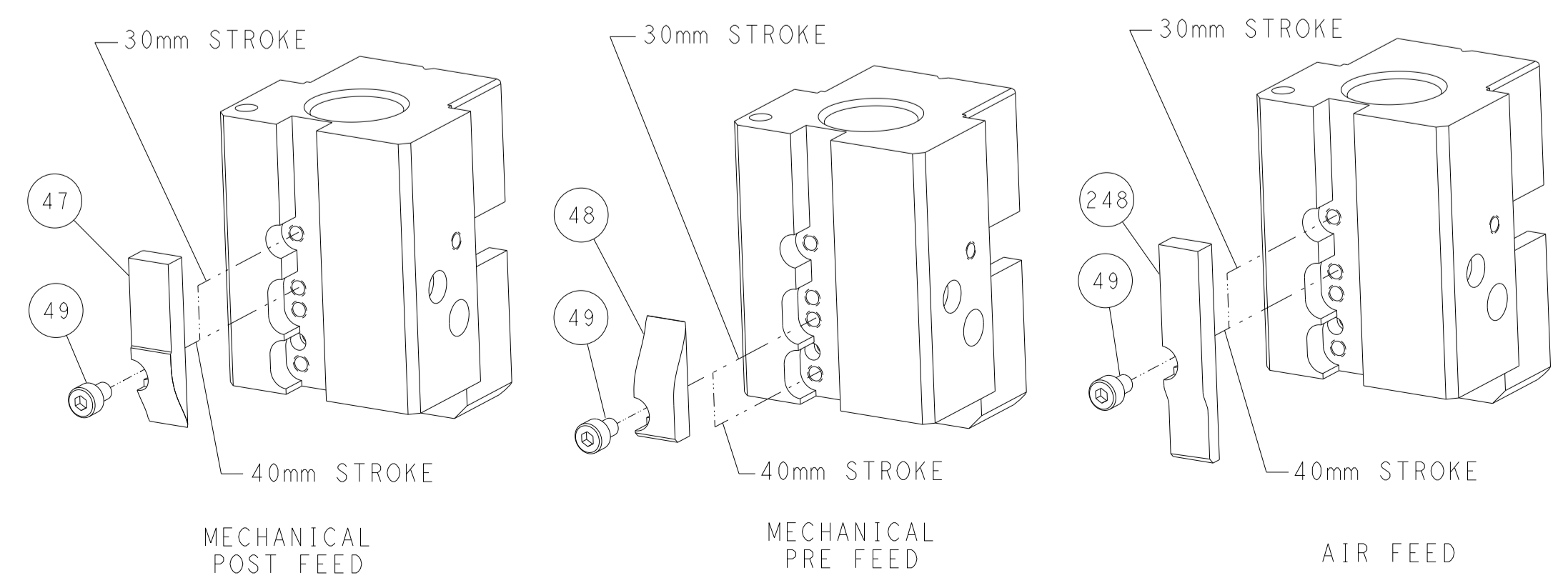

ATLANTIC VERSION
 Shown on sheets 1 of 4 & 2 of 4
 (Pacific version shown on sheets 3 of 4 & 4 of 4)

DIMENSIONS:		TOLERANCES UNLESS OTHERWISE SPECIFIED:		DWG: K. HUANG 15FEB2015		CHK: L. ZHANG 15FEB2015		NAME: Ocean End Feed Applicator	
mm	0 PLC ±	1 PLC ±	2 PLC ±	3 PLC ±	4 PLC ±	APVD: J. GUO	PRODUCT SPEC	SIZE: A1	CAGE CODE: 00779
MATERIAL:	FINISH:	WEIGHT:	SCALE: 1:1	SHEET: 2	OF: 4	REV: C	Customer Accessible Production Drawing		

PART NUMBER	REVISION	DESCRIPTION	FEED TYPE
2-2150530-1	C	FINE CRIMP HEIGHT ADJUST	MECHANICAL
2-2150530-2	C	FINE CRIMP HEIGHT ADJUST	PNEUMATIC
7-2150530-7	A	CRIMP TOOLING KIT	-

PACIFIC VERSION TERMINATOR
 INTERFACE ADAPTER

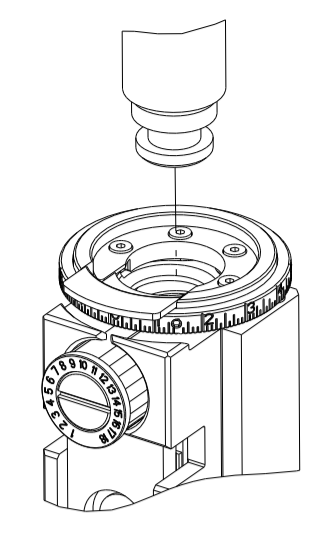

APPLICATOR DATA		
CRIMP	SIZE	TYPE
WIRE	1.02 mm [.040]	F
INSUL	-	-
APPL INSTRUCTIONS 408-35043		

TERMINAL DATA: TE TERMINAL		TE CRIMP SPECIFICATION	
TERMINAL NAME: SOLDER SPLICE			
WIRE STRIP LENGTH 4.40-5.00 mm [.173-.197 IN]		INSULATION DIAMETER RANGE Ø -	
TERMINAL APPLICATION SPECIFICATION	160725	-	-
TERMINALS APPLIED			
TE TERMINAL	TE TERMINAL	TE TERMINAL	TE TERMINAL
160725-1			

WIRE SIZE	CRIMP HEIGHT mm [INCH]	CRIMP HEIGHT REFERENCE SETTING
22 AWG OR 0.32mm ²	1.25+/-0.05 [.049+/-0.002]	8.7
24 AWG	1.07+/-0.05 [.042+/-0.002]	10.5
26 AWG	1.00+/-0.05 [.039+/-0.002]	11.2

- 1 RECOMMENDED SPARE PARTS
- 2 REFER TO SUPPLIED INSTRUCTION SHEET FOR CLEANING, LUBRICATION AND STORAGE OF APPLICATOR.
- 3 CRIMP HEIGHT REFERENCE SETTING WAS THE SETTING USED WHEN THE APPLICATOR WAS QUALIFIED AT THE FACTORY. ADJUSTMENT MAY BE NECESSARY WHEN RUNNING APPLICATOR IN THE FIELD.
- 4 TERMINAL LUBRICANT IS RECOMMENDED.
- 5. UNLESS SPECIFIED OTHERWISE TORQUE VALUES SHALL BE USED PER DOCUMENT, 101-35000.
- 6 REFER TO CUSTOMER DRAWING 160725 FOR CRIMP SPECIFICATION FRONT AND REAR BELLMOUT IS PERMITTED.

***WARNING**
 ON INSTALLATION, SET WIRE DISC TO CRIMP HEIGHT REFERENCE SETTING FOR LARGEST WIRE SIZE. CRIMP HEIGHT REFERENCE SETTINGS GREATER THAN THE VALUE SHOWN MAY CAUSE DAMAGE TO THE CRIMP TOOLING. REFER TO THE INSTRUCTION SHEET FOR PROPER SETUP AND ADJUSTMENTS.

PACIFIC VERSION
 Shown on sheets 3 of 4 & 4 of 4
 (Atlantic version shown on sheets 1 of 4 & 2 of 4)

LOC	DIST	REVISIONS					
		P	LTN	DESCRIPTION	DATE	OWN	APVD
A	66	-	-	SEE SHEET 1	-	-	-

-	-	1	2119580-1	MECHANICAL FEED ASSEMBLY	239
-	1	-	2844940-3	AIR FEED MODULE	238
-	4	4	2079383-9	SCR, BHSC, RoHS (M6 X 20)	186
-	REF	REF	994970-2	COUNTER, MAGNETIC	164
-	1	-	2119641-2	FEED CAM, AIR FEED	152
-	1	1	2168083-8	SCR, SKT HD CAP, RoHS, M4 X 16	144
-	-	1	2119653-2	FEED CAM, POST FEED	142
-	1	1	2119655-6	APPLICATOR BASIC ASSEMBLY, EF	141
-	1	1	1803518-2	RAM ASSEMBLY, EF PACIFIC	140
4	-	1	2119955-2	ASSY, LUBRICATOR, END FEED	84
-	1	1	455888-8	SPACER, CRIMPER	82
-	1	1	1803607-4	DOCUMENTATION PACKAGE	71
-	2	2	2-18032-2	SCR, SET, FLT PNT, M3 X 10.0	70
-	1	1	2119740-1	TAG, IDENTIFICATION	67
-	2	2	2168078-1	SCREW, DRIVE, RH, RoHS, 2 x .188	66
-	2	2	2168400-8	SHCS, LOW HEAD, RoHS, M4 X 16	64
-	1	1	5-18022-5	SCR, HEX HD CAP, M4 X 6.0	59
-	-	1	2063961-1	FEED FINGER	58
-	3	3	2168400-4	SHCS, LOW HEAD, RoHS, M4 X 8	57
-	2	2	5018030-1	NUT, HEX, REG, RoHS, M3	54
-	2	2	986965-8	NUT, LOCK, HEX, TORQUE (M4)	53
-	1	-	2063961-1	FEED FINGER	51
-	1	2	18023-9	SCR, SKT HD CAP M4 X 6.0	49
-	-	1	2119652-1	FEED CAM, PRE FEED	48
-	1	1	2-18024-7	SCR, BTN SKT HD CAP (M8 X 30.0)	41
-	7	7	1-18028-2	WASHER, FLAT, REG M4	33
-	2	2	2168083-9	SCR, SKT HD CAP, RoHS, M4 X 20	31
-	2	2	1-2168083-0	SCR, SKT HD CAP, RoHS, M4 X 10	29
-	1	1	240639-7	STRIPPER (MACHINING)	27
-	2	2	1-2168083-5	SCR, SKT HD CAP, RoHS, M4 X 30	25
-	1	1	1752371-1	PLATE, STRIP GUIDE	24
-	1	1	240825-6	PLATE, STRIP HOLD DOWN	23
-	2	2	2-22281-3	SPRING, COMPRESSION	22
-	1	1	1752373-4	DRAG	20
-	2	2	1901259-1	GUIDE, LOWER STRIP	18
1	-	1	240644-1	PLATE, REAR SHEAR	11
-	2	2	240645-3	SPACER, SHEAR PLATE	10
1	-	1	690619-4	PLATE, RETAINING	9
1	1	1	1803131-3	ANVIL, SPLICE TYPE	8
1	-	1	459722-3	BLADE, SHEAR	7
-	-	-	-	-	5
-	-	-	-	-	4
-	-	-	-	-	3
-	-	-	-	-	2
1	1	1	1803232-1	CRIMPER, WIRE F	1

DIMENSIONS:		TOLERANCES UNLESS OTHERWISE SPECIFIED:		MATERIAL:		FINISH:		WEIGHT:		SCALE:	
mm	0 PLC ±	1 PLC ±	2 PLC ±	3 PLC ±	4 PLC ±	ANGLES	FINISH	-	-	1:1	SHEET 3 OF 4

CHK	L. HUANG	15FEB2015	OWN	L. ZHANG	15FEB2015
APVD	J. GUO		NAME	Ocean End Feed Applicator	
PRODUCT SPEC			SIZE	CAGE CODE	DRAWING NO
APPLICATION SPEC			A1	00779	2150530
Customer Accessible Production Drawing			RESTRICTED TO	-	

REVISONS		DATE	OWN	APVD
LOC	DIST			
A	66			
P	LTN	DESCRIPTION		
		SEE SHEET 1		

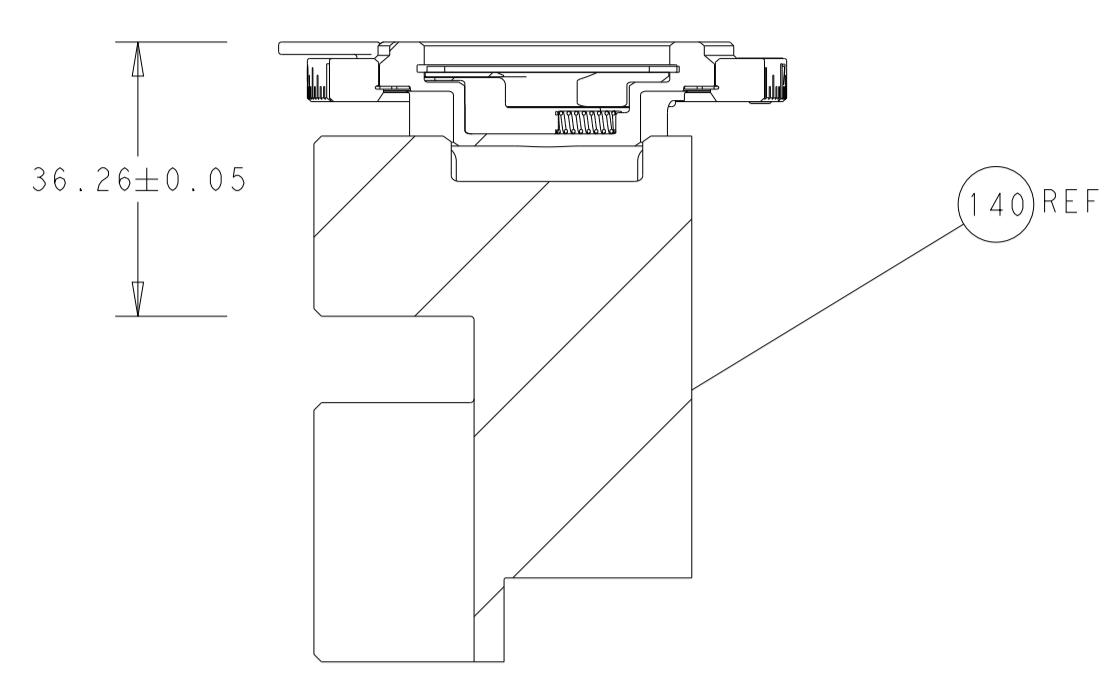

RAM SET-UP

FEED TYPE
MECHANICAL

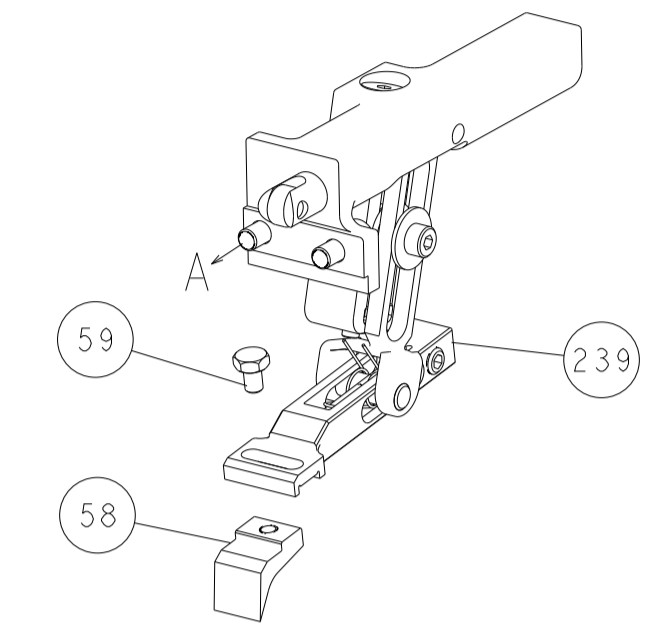

PNEUMATIC

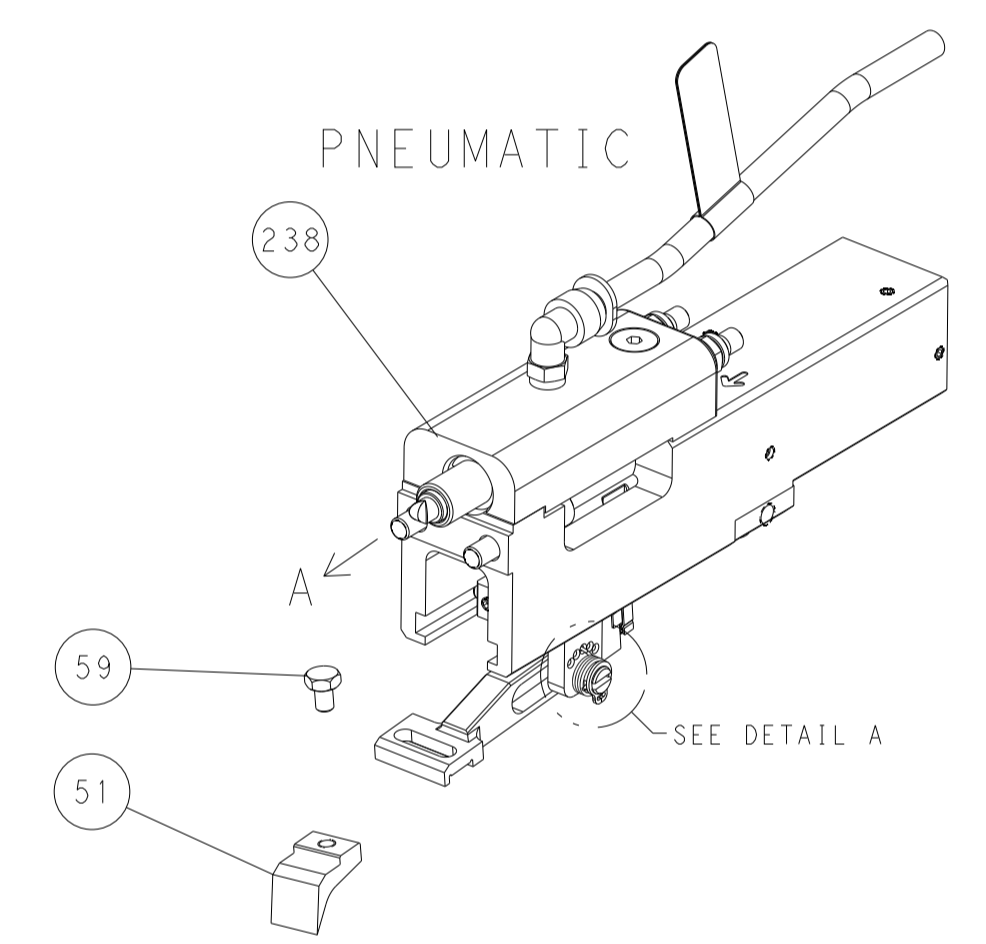

FEED SPRING
SETTING POSITION

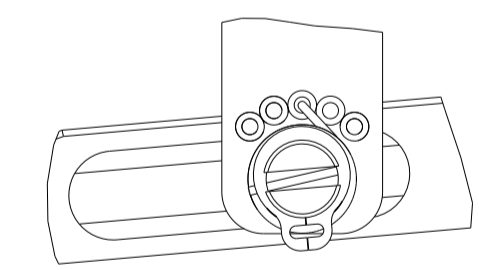

DETAIL A

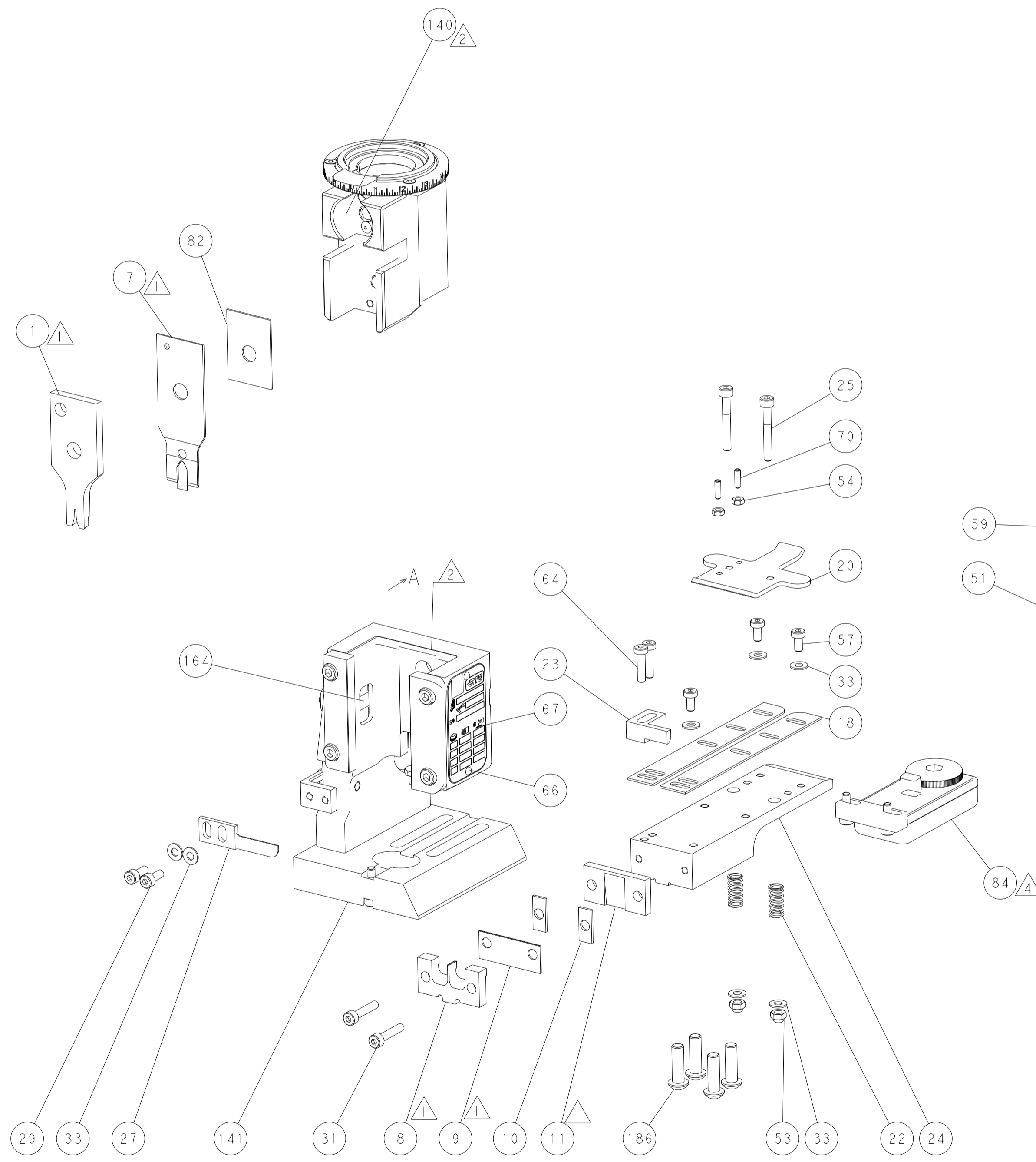

CAM POSITIONS

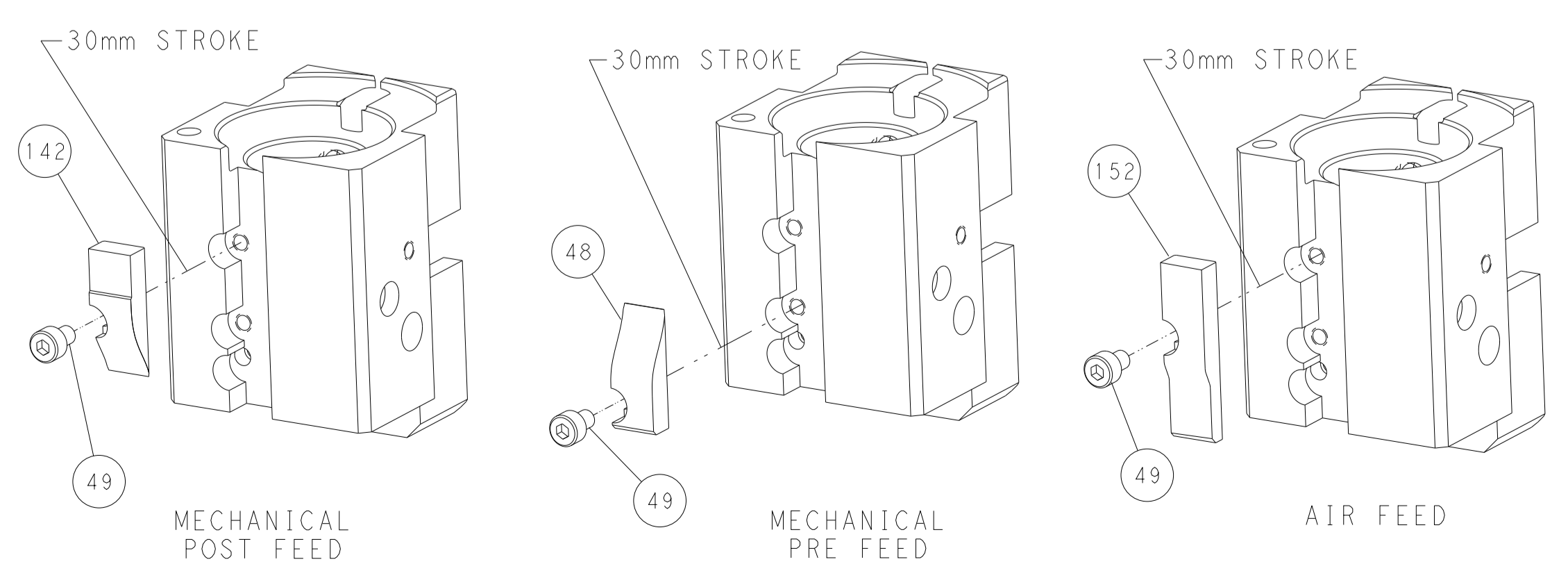

PACIFIC VERSION
 Shown on sheets 3 of 4 & 4 of 4
 (Atlantic version shown on sheets 1 of 4 & 2 of 4)

DIMENSIONS:		TOLERANCES UNLESS OTHERWISE SPECIFIED:		OWN: K. HUANG 15FEB2015		CHK: L. ZHANG 15FEB2015		NAME: STE TE Connectivity Harrisburg, PA 17105-3608	
mm	0 PLC ±	1 PLC ±	2 PLC ±	3 PLC ±	4 PLC ±	ANGLES ±	FINISH	APVD: U. GUO	PRODUCT SPEC
MATERIAL:								APPLICATION SPEC	
								WEIGHT	SIZE: CAGE CODE: DRAWING NO: A1 00779 ©=2150530
								Customer Accessible Production Drawing	SCALE: 1:1 SHEET 4 OF 4 REV C