

SKV Series



Skived Fin heat sinks can be an alternative to extruded heat sinks when looking for a fin density which can't be achieved by extrusion technology. Skived heat sinks can be manufactured from either copper or aluminum and usually have 0.5 (0.020") thick fins.

Skived heat sinks are produced using a series of sharp knives that, as they pass over the material, curl up a small thickness of metal which is then bent vertically to form the fin. Skived fins are produced from a bar of material which is approximately 16 feet in length and then cut to length as required by the final application.

The final heat sink can be machined using normal fabrication techniques. Because of the thin fins, care must be taken in handling to prevent damage. It is suggested that a shroud be placed over the fins to help prevent damage. Wakefield- Vette SKV Series offers standard off the shelf solutions for customer applications in addition to custom solutions utilizing a plastic pin attachment.

Features:

- Plastic push pin attachment for easy insertion
- Plastic pins ensure integrity of the PCB Board
- High fin densities in comparison to extrusion
- No interface between fins and base
- Minimal tooling cost for non-standards
- Improved thermal performance

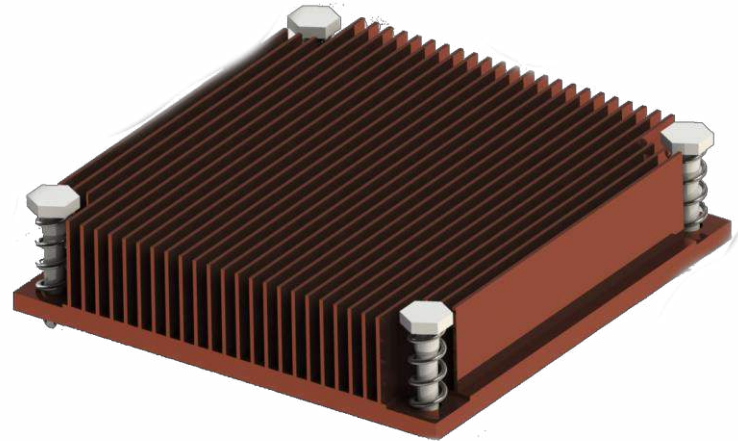

WKV Part Number	Description	Attachment Method	Length	Width	Height Off Base (Height of Fin)	Thermal Resistance @ Forced Air Flow	Thermal Resistance @ Natural	Material
SKV38538514-CU	COPPER HEATSINK 38.5X37.6X14MM	Plastic Push Pin	1.480" (37.59mm)	1.516" (38.50mm)	0.551" (14.00mm)	2.60°C/W @ 200 LFM	15.90°C/W	Copper
SKV38538514-AL	ALUMINUM HEATSINK 38.5X37.6X14MM	Plastic Push Pin	1.480" (37.59mm)	1.516" (38.50mm)	0.551" (14.00mm)	2.70°C/W @ 200 LFM	17.20°C/W	Aluminum
SKV4545225-CU	COPPER HEATSINK 45X44X22.5MM	Plastic Push Pin	1.732" (44.00mm)	1.772" (45.00mm)	0.886" (22.50mm)	1.65°C/W @ 200 LFM	8.00°C/W	Copper
SKV4545225-AL	ALUMINUM HEATSINK 45X44X22.5MM	Plastic Push Pin	1.732" (44.00mm)	1.772" (45.00mm)	0.886" (22.50mm)	1.75°C/W @ 200 LFM	8.70°C/W	Aluminum
SKV505014-CU	COPPER HEATSINK 50X50X14MM	Plastic Push Pin	1.969" (50.00mm)	1.969" (50.00mm)	0.551" (14.00mm)	2.10°C/W @ 200 LFM	8.90°C/W	Copper
SKV505014-AL	ALUMINUM HEATSINK 50X50X14MM	Plastic Push Pin	1.969" (50.00mm)	1.969" (50.00mm)	0.551" (14.00mm)	2.20°C/W @ 200 LFM	9.90°C/W	Aluminum
SKV585811-CU	COPPER HEATSINK 57.9X59X11MM	Plastic Push Pin	2.323" (59.00mm)	2.280" (57.91mm)	0.433" (11.00mm)	1.90°C/W @ 200 LFM	7.70°C/W	Copper
SKV585811-AL	ALUMINUM HEATSINK 57.9X59X11MM	Plastic Push Pin	2.323" (59.00mm)	2.280" (57.91mm)	0.433" (11.00mm)	2.00°C/W @ 200 LFM	8.40°C/W	Aluminum
SKV606014-CU	COPPER HEATSINK 60X60X14MM	Plastic Push Pin	2.362" (60.00mm)	2.362" (60.00mm)	0.551" (14.00mm)	1.70°C/W @ 200 LFM	7.00°C/W	Copper
SKV606014-AL	ALUMINUM HEATSINK 60X60X14MM	Plastic Push Pin	2.362" (60.00mm)	2.362" (60.00mm)	0.551" (14.00mm)	1.80°C/W @ 200 LFM	7.60°C/W	Aluminum
SKV606021-CU	COPPER HEATSINK 60X60X21MM	Plastic Push Pin	2.362" (60.00mm)	2.362" (60.00mm)	0.866" (21.00mm)	0.80°C/W @ 300 LFM	7.20°C/W	Copper
SKV606021-AL	ALUMINUM HEATSINK 60X60X21MM	Plastic Push Pin	2.362" (60.00mm)	2.362" (60.00mm)	0.866" (21.00mm)	0.90°C/W @ 200 LFM	7.90°C/W	Aluminum
SKV707014-CU	COPPER HEATSINK 70X70X14MM	Plastic Push Pin	2.717" (69.00mm)	2.756" (70.00mm)	0.551" (14.00mm)	1.40°C/W @ 200 LFM	5.60°C/W	Copper
SKV707014-AL	ALUMINUM HEATSINK 70X70X14MM	Plastic Push Pin	2.717" (69.00mm)	2.756" (70.00mm)	0.551" (14.00mm)	1.50°C/W @ 200 LFM	6.30°C/W	Aluminum
SKV808012-CU	COPPER HEATSINK 80X80X12MM	Plastic Push Pin	3.150" (80.00mm)	3.150" (80.00mm)	0.472" (12.00mm)	1.20°C/W @ 200 LFM	5.10°C/W	Copper
SKV808012-AL	ALUMINUM HEATSINK 80X80X12MM	Plastic Push Pin	3.150" (80.00mm)	3.150" (80.00mm)	0.472" (12.00mm)	1.30°C/W @ 200 LFM	5.70°C/W	Aluminum
SKV909010-CU	COPPER HEATSINK 90X90X10MM	Plastic Push Pin	3.543" (90.00mm)	3.543" (90.00mm)	0.394" (10.00mm)	1.30°C/W @ 200 LFM	4.50°C/W	Copper
SKV909010-AL	ALUMINUM HEATSINK 90X90X10MM	Plastic Push Pin	3.543" (90.00mm)	3.543" (90.00mm)	0.394" (10.00mm)	1.40°C/W @ 200 LFM	5.00°C/W	Aluminum

SKV Series

WKV Part Number	Description	Attachment Method	Length	Width	Height Off Base (Height of Fin)	Thermal Resistance @ Forced Air Flow	Thermal Resistance @ Natural
SKV38538514-CU	COPPER HEATSINK 38.5X37.6X14MM	Plastic Push Pin	1.480" (37.59mm)	1.516" (38.50mm)	0.551" (14.00mm)	2.60°C/W @ 200 LFM	15.90°C/W
SKV38538514-AL	ALUMINUM HEATSINK 38.5X37.6X14MM	Plastic Push Pin	1.480" (37.59mm)	1.516" (38.50mm)	0.551" (14.00mm)	2.70°C/W @ 200 LFM	17.20°C/W

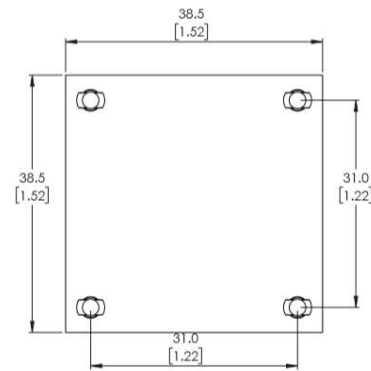
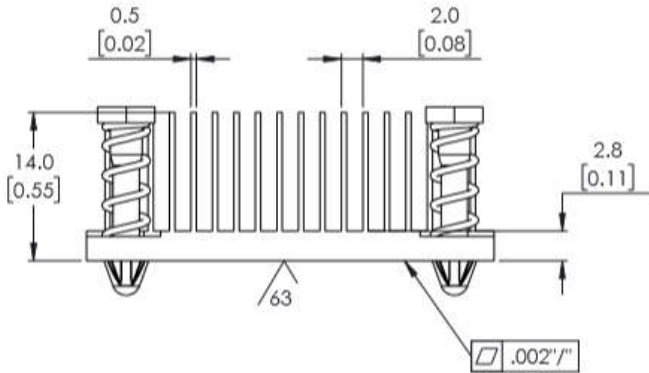

NOTES:

1. INCLUDES 4 PLASTIC PUSHPIN/SPRINGS
2. SUGGESTED PCB HOLES SIZE: $\phi 3.1 \pm 0.3$ ($\phi 0.122 \pm 0.001$)
3. MAXIMUM STACKUP (PCB+COMPONENT) = 4.0MM (0.157)

WKV Part Number	Description	Attachment Method	Length	Width	Height Off Base (Height of Fin)	Thermal Resistance @ Forced Air Flow	Thermal Resistance @ Natural	Material
SKV4545225-CU	COPPER HEATSINK 45X44X22.5MM	Plastic Push Pin	1.732" (44.00mm)	1.772" (45.00mm)	0.886" (22.50mm)	1.65°C/W @ 200 LFM	8.00°C/W	Copper
SKV4545225-AL	ALUMINUM HEATSINK 45X44X22.5MM	Plastic Push Pin	1.732" (44.00mm)	1.772" (45.00mm)	0.886" (22.50mm)	1.75°C/W @ 200 LFM	8.70°C/W	Aluminum

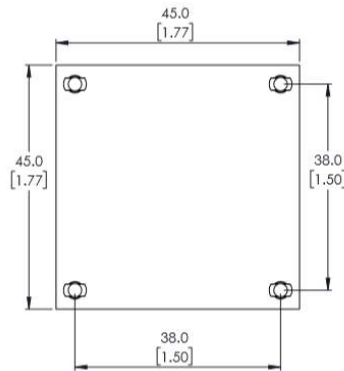

NOTES:

1. INCLUDES 4 PLASTIC PUSHPIN/SPRINGS
2. SUGGESTED PCB HOLES SIZE: $\phi 3.1 \pm 0.3$ ($\phi 0.122 \pm 0.001$)
3. MAXIMUM STACKUP (PCB+COMPONENT) = 4.0MM (0.157)

WKV Part Number	Description	Attachment Method	Length	Width	Height Off Base (Height of Fin)	Thermal Resistance @ Forced Air Flow	Thermal Resistance @ Natural	Material
SKV505014-CU	COPPER HEATSINK 50X50X14MM	Plastic Push Pin	1.969" (50.00mm)	1.969" (50.00mm)	0.551" (14.00mm)	2.10°C/W @ 200 LFM	8.90°C/W	Copper
SKV505014-AL	ALUMINUM HEATSINK 50X50X14MM	Plastic Push Pin	1.969" (50.00mm)	1.969" (50.00mm)	0.551" (14.00mm)	2.20°C/W @ 200 LFM	9.90°C/W	Aluminum

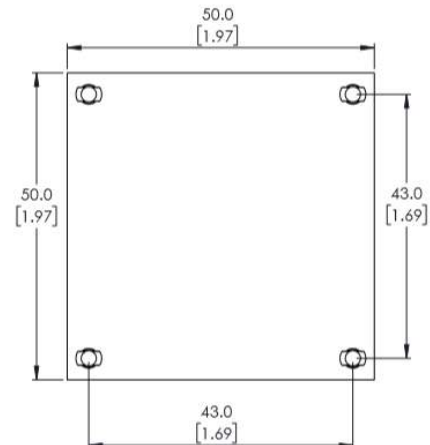
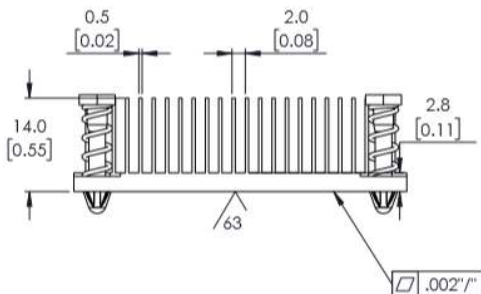

NOTES:

1. INCLUDES 4 PLASTIC PUSHPIN/SPRINGS
2. SUGGESTED PCB HOLES SIZE: $\phi 3.1 \pm 0.3$ ($\phi 0.122 \pm 0.001$)
3. MAXIMUM STACKUP (PCB+COMPONENT) = 4.0MM (0.157)

Copper & Aluminum Skived Fin Heat Sink

SKV Series

WKV Part Number	Description	Attachment Method	Length	Width	Height Off Base (Height of Fin)	Thermal Resistance @ Forced Air Flow	Thermal Resistance @ Natural	Material
SKV585811-CU	COPPER HEATSINK 57.9X59X11MM	Plastic Push Pin 2.323" (59.00mm)	2.280" (57.91mm)	2.280" (57.91mm)	0.433" (11.00mm)	1.90°C/W @ 200 LFM	7.70°C/W	Copper
SKV585811-AL	ALUMINUM HEATSINK 57.9X59X11MM	Plastic Push Pin 2.323" (59.00mm)	2.280" (57.91mm)	2.280" (57.91mm)	0.433" (11.00mm)	2.00°C/W @ 200 LFM	8.40°C/W	Aluminum

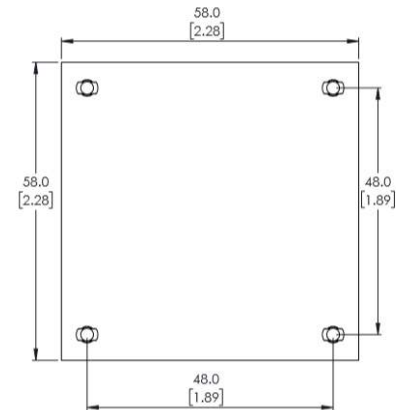
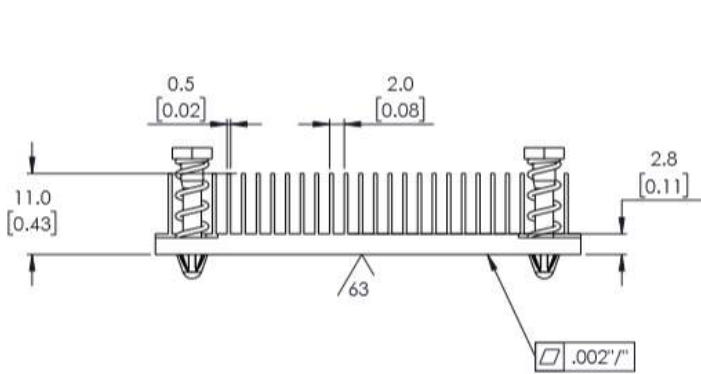

NOTES:

1. INCLUDES 4 PLASTIC PUSHPIN/SPRINGS
2. SUGGESTED PCB HOLES SIZE: $\phi 3.1 \pm 0.3$ ($\phi 0.122 \pm 0.001$)
3. MAXIMUM STACKUP (PCB+COMPONENT) = 4.0MM (0.157)

WKV Part Number	Description	Attachment Method	Length	Width	Height Off Base (Height of Fin)	Thermal Resistance @ Forced Air Flow	Thermal Resistance @ Natural	Material
SKV606014-CU	COPPER HEATSINK 60X60X14MM	Plastic Push Pin 2.362" (60.00mm)	2.362" (60.00mm)	2.362" (60.00mm)	0.551" (14.00mm)	1.70°C/W @ 200 LFM	7.00°C/W	Copper
SKV606014-AL	ALUMINUM HEATSINK 60X60X14MM	Plastic Push Pin 2.362" (60.00mm)	2.362" (60.00mm)	2.362" (60.00mm)	0.551" (14.00mm)	1.80°C/W @ 200 LFM	7.60°C/W	Aluminum

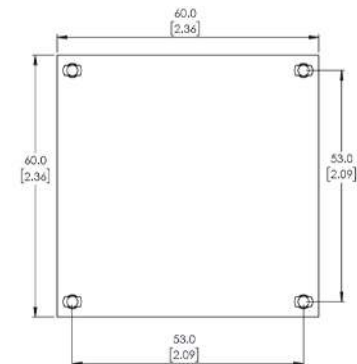
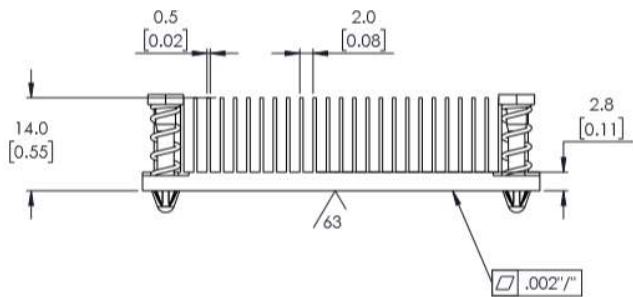

NOTES:

1. INCLUDES 4 PLASTIC PUSHPIN/SPRINGS
2. SUGGESTED PCB HOLES SIZE: $\phi 3.1 \pm 0.3$ ($\phi 0.122 \pm 0.001$)
3. MAXIMUM STACKUP (PCB+COMPONENT) = 4.0MM (0.157)

WKV Part Number	Description	Attachment Method	Length	Width	Height Off Base (Height of Fin)	Thermal Resistance @ Forced Air Flow	Thermal Resistance @ Natural	Material
SKV606021-CU	COPPER HEATSINK 60X60X21MM	Plastic Push Pin 2.362" (60.00mm)	2.362" (60.00mm)	2.362" (60.00mm)	0.866" (21.00mm)	0.80°C/W @ 300 LFM	7.20°C/W	Copper
SKV606021-AL	ALUMINUM HEATSINK 60X60X21MM	Plastic Push Pin 2.362" (60.00mm)	2.362" (60.00mm)	2.362" (60.00mm)	0.866" (21.00mm)	0.90°C/W @ 200 LFM	7.90°C/W	Aluminum

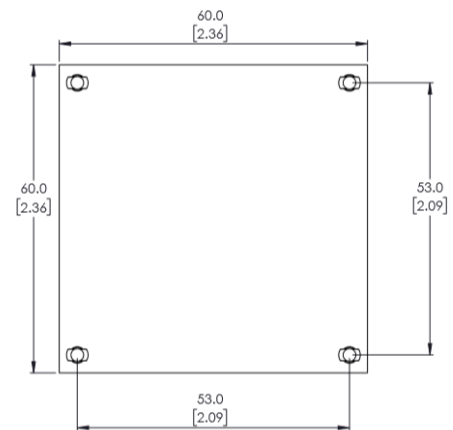
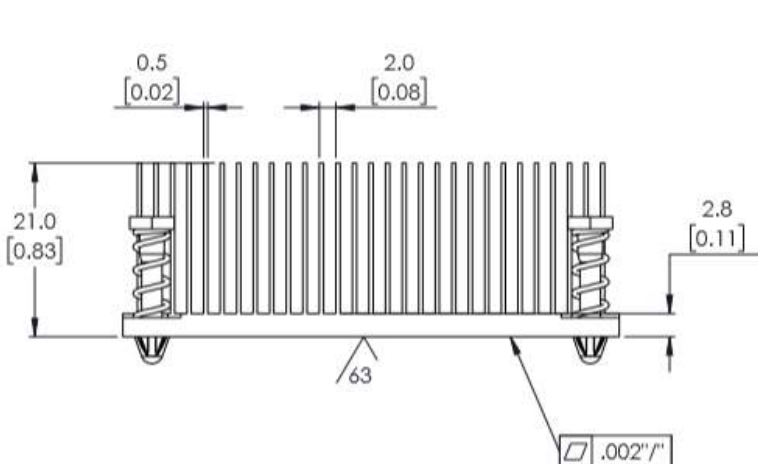

NOTES:

1. INCLUDES 4 PLASTIC PUSHPIN/SPRINGS
2. SUGGESTED PCB HOLES SIZE: $\phi 3.1 \pm 0.3$ ($\phi 0.122 \pm 0.001$)
3. MAXIMUM STACKUP (PCB+COMPONENT) = 4.0MM (0.157)

SKV Series

WKV Part Number	Description	Attachment Method	Length	Width	Height Off Base (Height of Fin)	Thermal Resistance @ Forced Air Flow	Thermal Resistance @ Natural	Material
SKV707014-CU	COPPER HEATSINK 70X70X14MM	Plastic Push Pin	2.717" (69.00mm)	2.756" (70.00mm)	0.551" (14.00mm)	1.40°C/W @ 200 LFM	5.60°C/W	Copper
SKV707014-AL	ALUMINUM HEATSINK 70X70X14MM	Plastic Push Pin	2.717" (69.00mm)	2.756" (70.00mm)	0.551" (14.00mm)	1.50°C/W @ 200 LFM	6.30°C/W	Aluminum

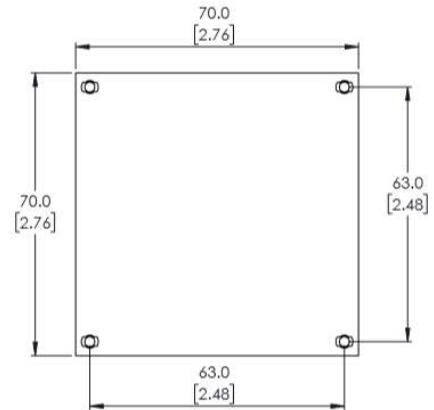
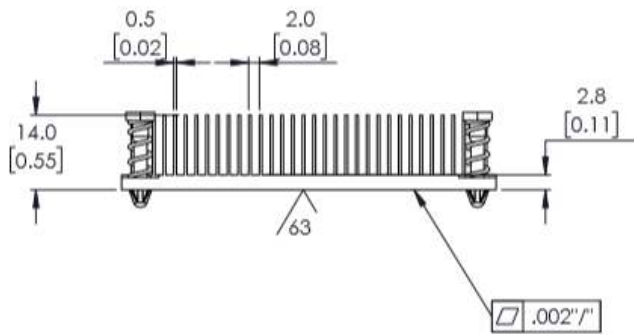

NOTI

1. INCLUDES 4 PLASTIC PUSHPIN/SPRINGS
2. SUGGESTED PCB HOLES SIZE: $\phi 3.1 \pm 0.3$ ($\phi 0.122 \pm 0.001$)
3. MAXIMUM STACKUP (PCB+COMPONENT) = 4.0MM (0.157)

WKV Part Number	Description	Attachment Method	Length	Width	Height Off Base (Height of Fin)	Thermal Resistance @ Forced Air Flow	Thermal Resistance @ Natural	Material
SKV808012-CU	COPPER HEATSINK 80X80X12MM	Plastic Push Pin	3.150" (80.00mm)	3.150" (80.00mm)	0.472" (12.00mm)	1.20°C/W @ 200 LFM	5.10°C/W	Copper
SKV808012-AL	ALUMINUM HEATSINK 80X80X12MM	Plastic Push Pin	3.150" (80.00mm)	3.150" (80.00mm)	0.472" (12.00mm)	1.30°C/W @ 200 LFM	5.70°C/W	Aluminum

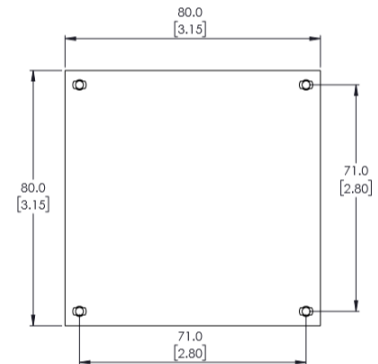
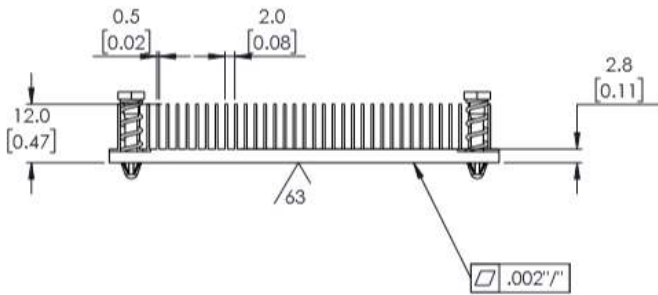

NOTES:

1. INCLUDES 4 PLASTIC PUSHPIN/SPRINGS
2. SUGGESTED PCB HOLES SIZE: $\phi 3.1 \pm 0.3$ ($\phi 0.122 \pm 0.001$)
3. MAXIMUM STACKUP (PCB+COMPONENT) = 4.0MM (0.157)

WKV Part Number	Description	Attachment Method	Length	Width	Height Off Base (Height of Fin)	Thermal Resistance @ Forced Air Flow	Thermal Resistance @ Natural	Material
SKV909010-CU	COPPER HEATSINK 90X90X10MM	Plastic Push Pin	3.543" (90.00mm)	3.543" (90.00mm)	0.394" (10.00mm)	1.30°C/W @ 200 LFM	4.50°C/W	Copper
SKV909010-AL	ALUMINUM HEATSINK 90X90X10MM	Plastic Push Pin	3.543" (90.00mm)	3.543" (90.00mm)	0.394" (10.00mm)	1.40°C/W @ 200 LFM	5.00°C/W	Aluminum

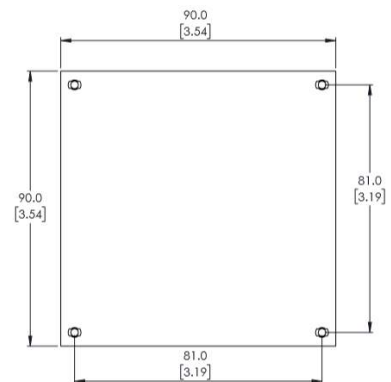
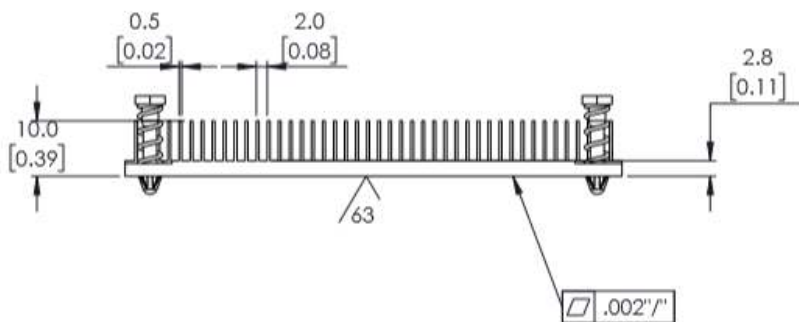

NOTES:

1. INCLUDES 4 PLASTIC PUSHPIN/SPRINGS
2. SUGGESTED PCB HOLES SIZE: $\phi 3.1 \pm 0.3$ ($\phi 0.122 \pm 0.001$)
3. MAXIMUM STACKUP (PCB+COMPONENT) = 4.0MM (0.157)