

Clock Synthesizer with Differential SRC and CPU Outputs

Features

- CK409B-compliant
- Supports Intel Pentium® 4-type CPUs
- Selectable CPU frequencies
- 3.3V power supply
- Ten copies of PCI clocks
- Two copies 48 MHz clock
- Five copies of 3V66 with one optional VCH
- Four differential CPU clock pairs
- One differential SRC clock
- I²C support with readback capabilities
- Ideal Lexmark Spread Spectrum profile for maximum electromagnetic interference (EMI) reduction
- 56-pin SSOP package

CPU	SRC	3V66	PCI	REF	48M
x 4	x 1	x 5	x 10	x 2	x 2

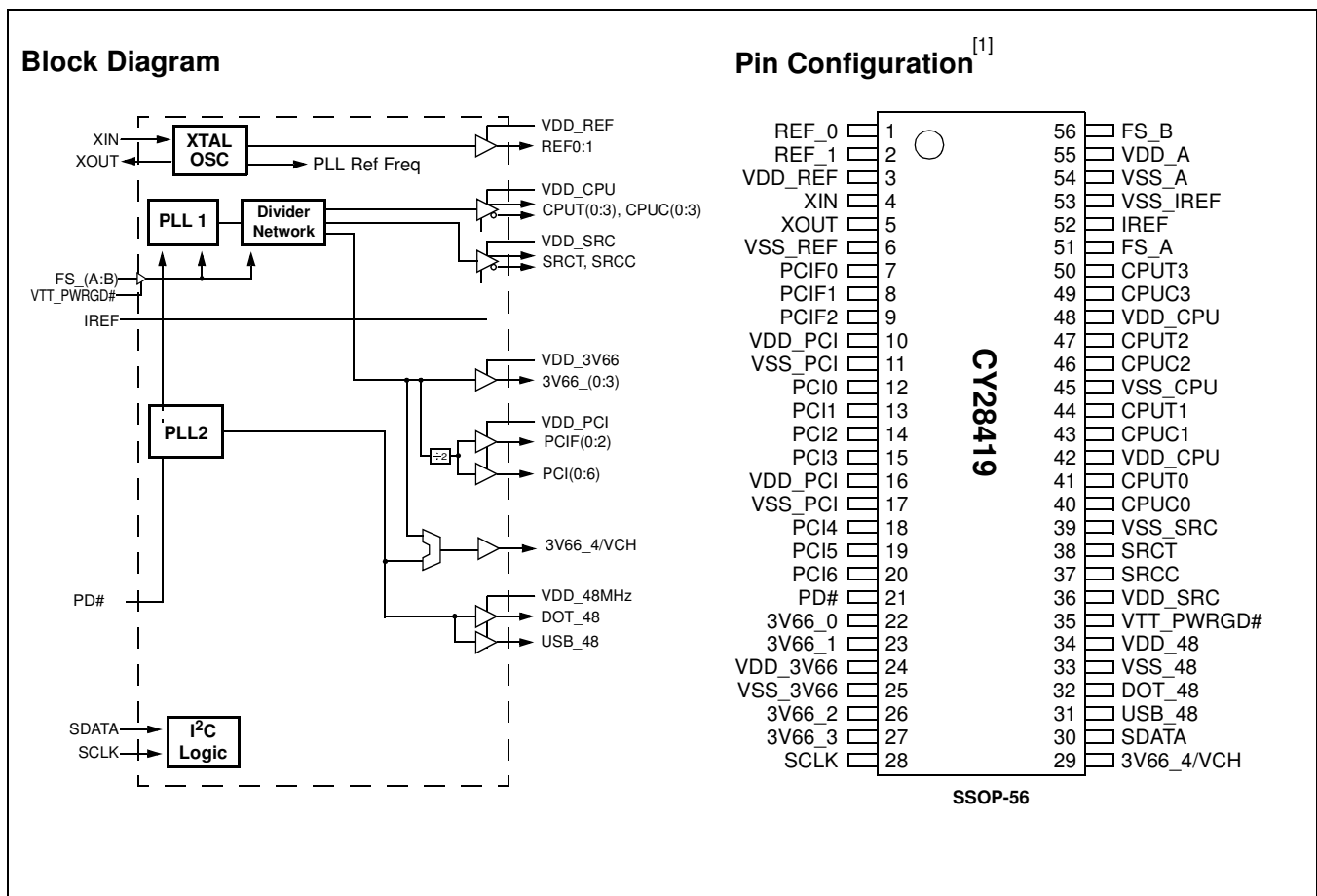

Note:

1. Signals marked with [*] and [**] have internal pull-up and pull-down resistors, respectively.

Pin Description

Pin No.	Pin Name	Pin Type	Pin Description
1,2	REF(0:1)	O, SE	Reference Clock. 3.3V 14.318-Mz clock output.
4	XIN	I	Crystal Connection or External Reference Frequency Input. This pin has dual functions. It can be used as an external 14.318-MHz crystal connection or as an external reference frequency input.
5	XOUT	O, SE	Crystal Connection. Connection for an external 14.318-MHz crystal output.
41,44,47,50	CPUT(0:3)	O, DIF	CPU Clock Output. Differential CPU clock outputs. See <i>Table 1</i> for frequency configuration.
40,43,46,49	CPUC(0:3)	O, DIF	CPU Clock Output. Differential CPU clock outputs. See <i>Table 1</i> for frequency configuration.
38, 37	SRCT, SRCC	O, DIF	Differential serial reference clock.
22,23,26,27	3V66(3:0)	O, SE	66 MHz Clock Output. 3.3V 66-MHz clock from internal VCO.
29	3V66_4VCH	O, SE	48/66 MHz Clock Output. 3.3V selectable through SMBus to be 66 or 48 MHz.
7,8,9	PCIF(0:2)	O, SE	Free Running PCI Output. 33-MHz clocks divided down from 3V66.
12,13,14,15,18,19,20	PCI(0:6)	O, SE	PCI Clock Output. 33-MHz clocks divided down from 3V66.
31,	USB_48	O, SE	Fixed 48 MHz clock output.
32	DOT_48	O, SE	Fixed 48 MHz clock output.
51,56	FS_A, FS_B	I	3.3V LVTTTL input for CPU frequency selection.
52	IREF	I	Current Reference. A precision resistor is attached to this pin which is connected to the internal current reference.
21	PD#	I, PU	3.3V LVTTTL input for power-down# active LOW.
35	VTT_PWRGD#	I	3.3V LVTTTL input is a level-sensitive strobe used to latch the FS0 input (active LOW).
30	SDATA	I/O	SMBus-compatible SDATA.
28	SCLK	I	SMBus-compatible SCLOCK.
53	VSS_IREF	GND	Ground for current reference.
55	VDD_A	PWR	3.3V power supply for PLL.
54	VSS_A	GND	Ground for PLL.
42,48	VDD_CPU	PWR	3.3V power supply for outputs.
45	VSS_CPU	GND	Ground for outputs.
36	VDD_SRC	PWR	3.3V power supply for outputs.
39	VSS_SRC	GND	Ground for outputs.
34	VDD_48	PWR	3.3V power supply for outputs.
33	VSS_48	GND	Ground for outputs.
10,16	VDD_PCI	PWR	3.3V power supply for outputs.
11,17	VSS_PCI	GND	Ground for outputs.
24	VDD_3V66	PWR	3.3V power supply for outputs.
25	VSS_3V66	GND	Ground for outputs.
3	VDD_REF	PWR	3.3V power supply for outputs.
6	VSS_REF	GND	Ground for outputs.

Frequency Select Pins (FS_A, FS_B)

Host clock frequency selection is achieved by applying the appropriate logic levels to FS_A and FS_B inputs prior to VTT_PWRGD# assertion (as seen by the clock synthesizer). Upon VTT_PWRGD# being sampled low by the clock chip (indicating processor VTT voltage is stable), the clock chip samples the FS_A and FS_B input values. For all logic levels of FS_A and FS_B except MID, VTT_PWRGD# employs a one-shot functionality in that once a valid low on

VTT_PWRGD# has been sampled low, all further VTT_PWRGD#, FS_A and FS_B transitions will be ignored. In the case where FS_B is at mid level when VTT_PWRGD# is sampled low, the clock chip will assume "Test Clock Mode". Once "Test Clock Mode" has been invoked, all further FS_B transitions will be ignored and FS_A will asynchronously select between the Hi-Z and REF/N mode. Exiting test mode is accomplished by cycling power with FS_B in a high or low state.

Table 1. Frequency Select Table (FS_A FS_B)

FS_A	FS_B	CPU	SRC	3V66	PCIF/PCI	REF0	REF1	USB/DOT
0	0	100 MHz	100/200 MHz	66 MHz	33 MHz	14.3 MHz	14.31 MHz	48 MHz
0	MID	REF/N	REF/N	REF/N	REF/N	REF/N	REF/N	REF/N
0	1	200 MHz	100/200 MHz	66 MHz	33 MHz	14.3 MHz	14.31 MHz	48 MHz
1	0	133 MHz	100/200 MHz	66 MHz	33 MHz	14.3 MHz	14.31 MHz	48 MHz
1	1	166 MHz	100/200 MHz	66 MHz	33 MHz	14.3 MHz	14.31 MHz	48 MHz
1	MID	Hi-Z	Hi-Z	Hi-Z	Hi-Z	Hi-Z	Hi-Z	Hi-Z

Table 2. Frequency Select Table (FS_A FS_B) SMBus Bit 5 of Byte 6 = 1

FS_A	FS_B	CPU	SRC	3V66	PCIF/PCI	REF0	REF1	USB/DOT
0	0	200 MHz	100/200 MHz	66 MHz	33 MHz	14.3 MHz	14.31 MHz	48 MHz
0	1	400 MHz	100/200 MHz	66 MHz	33 MHz	14.3 MHz	14.31 MHz	48 MHz
1	0	266 MHz	100/200 MHz	66 MHz	33 MHz	14.3 MHz	14.31 MHz	48 MHz
1	1	333 MHz	100/200 MHz	66 MHz	33 MHz	14.3 MHz	14.31 MHz	48 MHz

Serial Data Interface

To enhance the flexibility and function of the clock synthesizer, a two-signal serial interface is provided. Through the Serial Data Interface, various device functions, such as individual clock output buffers, can be individually enabled or disabled. The registers associated with the Serial Data Interface initialize to their default setting upon power-up, and therefore use of this interface is optional. Clock device register changes are normally made upon system initialization, if any are required. The interface cannot be used during system operation for power management functions.

Data Protocol

The clock driver serial protocol accepts byte write, byte read, block write, and block read operations from the controller. For block write/read operation, the bytes must be accessed in sequential order from lowest to highest byte (most significant bit

first) with the ability to stop after any complete byte has been transferred. For byte write and byte read operations, the system controller can access individually indexed bytes. The offset of the indexed byte is encoded in the command code, as described in *Table 3*.

The block write and block read protocol is outlined in *Table 4* while *Table 5* outlines the corresponding byte write and byte read protocol. The slave receiver address is 11010010 (D2h).

Table 3. Command Code Definition

Bit	Description
7	0 = Block read or block write operation, 1 = Byte read or byte write operation
(6:0)	Byte offset for byte read or byte write operation. For block read or block write operations, these bits should be '0000000'

Table 4. Block Read and Block Write Protocol

Block Write Protocol		Block Read Protocol	
Bit	Description	Bit	Description
1	Start	1	Start
2:8	Slave address – 7 bits	2:8	Slave address – 7 bits
9	Write = 0	9	Write = 0
10	Acknowledge from slave	10	Acknowledge from slave
11:18	Command Code – 8 bits '00000000' stands for block operation	11:18	Command Code – 8 bits '00000000' stands for block operation

Table 4. Block Read and Block Write Protocol (continued)

Block Write Protocol		Block Read Protocol	
19	Acknowledge from slave	19	Acknowledge from slave
20:27	Byte Count – 8 bits	20	Repeat start
28	Acknowledge from slave	21:27	Slave address – 7 bits
29:36	Data byte 1 – 8 bits	28	Read = 1
37	Acknowledge from slave	29	Acknowledge from slave
38:45	Data byte 2 – 8 bits	30:37	Byte count from slave – 8 bits
46	Acknowledge from slave	38	Acknowledge from master
....	39:46	Data byte from slave – 8 bits
....	Data Byte (N-1) –8 bits	47	Acknowledge from master
....	Acknowledge from slave	48:55	Data byte from slave – 8 bits
....	Data Byte N –8 bits	56	Acknowledge from master
....	Acknowledge from slave	Data byte N from slave – 8 bits
....	Stop	Acknowledge from master
		Stop

Table 5. Byte Read and Byte Write Protocol

Byte Write Protocol		Byte Read Protocol	
Bit	Description	Bit	Description
1	Start	1	Start
2:8	Slave address – 7 bits	2:8	Slave address – 7 bits
9	Write = 0	9	Write = 0
10	Acknowledge from slave	10	Acknowledge from slave
11:18	Command Code – 8 bits '100xxxxx' stands for byte operation, bits[6:0] of the command code represents the offset of the byte to be accessed	11:18	Command Code – 8 bits '100xxxxx' stands for byte operation, bits[6:0] of the command code represents the offset of the byte to be accessed
19	Acknowledge from slave	19	Acknowledge from slave
20:27	Data byte from master – 8 bits	20	Repeat start
28	Acknowledge from slave	21:27	Slave address – 7 bits
29	Stop	28	Read = 1
		29	Acknowledge from slave
		30:37	Data byte from slave – 8 bits
		38	Acknowledge from master
		39	Stop

Byte 0: Control Register 0

Bit	@Pup	Name	Description
7	0	Reserved	Reserved
6	1	Reserved	Reserved
5	0	Reserved	Reserved
4	0	Reserved	Reserved
3	1	Reserved	Reserved
2	1	Reserved	Reserved
1	Externally Selected	FS_B	FS_B reflects the value of the FS_B pin sampled on power-up. 0 = FS_B low at power-up
0	Externally Selected	FS_A	FS_A reflects the value of the FS_A pin sampled on power-up. 0 = FS_A low at power-up

Byte 1: Control Register 1

Bit	@Pup	Name	Description
7	0	SRCT, SRCC	Allow control of SRCT/C with assertion of PCI_STP# 0 = Free Running, 1 = Stopped with PCI_STP#
6	1	SRCT, SRCC	SRCT/C Output Enable 0 = Disabled (three-state), 1 = Enabled
5	1	Reserved	Reserved
4	1	Reserved	Reserved
3	1	Reserved	Reserved
2	1	CPUT2, CPUC2	CPUT/C2 Output Enable 0 = Disabled (three-state), 1 = Enabled
1	1	CPUT1, CPUC1	CPUT/C1 Output Enable, 0 = Disabled (three-state), 1 = Enabled
0	1	CPUT0, CPUC0	CPUT/C0 Output Enable 0 = Disabled (three-state), 1 = Enabled

Byte 2: Control Register 2

Bit	@Pup	Name	Description
7	0	SRCT, SRCC	SRCT/C Pwrdown drive mode 0 = Driven in power-down, 1 = Three-state in power-down
6	0	SRCT, SRCC	SRCT/C Stop drive mode 0 = Driven in PCI_STP, 1 = Three-state in power-down
5	0	CPUT2, CPUC2	CPUT/C2 Pwrdown drive mode 0 = Driven in power-down, 1 = Three-state in power-down
4	0	CPUT1, CPUC1	CPUT/C1 Pwrdown drive mode 0 = Driven in power-down, 1 = Three-state in power-down
3	0	CPUT0, CPUC0	CPUT/C0 Pwrdown drive mode 0 = Driven in power-down, 1 = Three-state in power-down
2	0	Reserved	Reserved
1	0	Reserved	Reserved
0	0	Reserved	Reserved

Byte 3: Control Register 3

Bit	@Pup	Name	Description
7	1	All PCI and SRC Clock outputs except PCIF and SRC clocks set to free-running	PCI_STP Control. 0 = SW PCI_STP not enabled and only the PCI_STP# pin will stop the PCI stop enabled outputs, 1 = the PCI_STP function is enabled and the stop enabled outputs will be stopped in a synchronous manner with no short pulses.
6	1	PCI6	PCI6 Output Enable 0 = Disabled, 1 = Enabled
5	1	PCI5	PCI5 Output Enable 0 = Disabled, 1 = Enabled
4	1	PCI4	PCI4 Output Enable 0 = Disabled, 1 = Enabled
3	1	PCI3	PCI3 Output Enable 0 = Disabled, 1 = Enabled
2	1	PCI2	PCI2 Output Enable 0 = Disabled, 1 = Enabled
1	1	PCI1	PCI1 Output Enable 0 = Disabled, 1 = Enabled
0	1	PCI0	PCI0 Output Enable 0 = Disabled, 1 = Enabled

Byte 4: Control Register 4

Bit	@Pup	Name	Description
7	0	USB_48MHz	USB_48 Drive Strength 0 = High drive strength, 1 = Normal drive strength
6	1	USB_48MHz	USB_48 Output Enable 0 = Disabled, 1 = Enabled
5	0	PCIF2	Allow control of PCIF2 with assertion of PCI_STP# 0 = Free Running, 1 = Stopped with PCI_STP#
4	0	PCIF1	Allow control of PCIF1 with assertion of PCI_STP# 0 = Free Running, 1 = Stopped with PCI_STP#
3	0	PCIF0	Allow control of PCIF0 with assertion of PCI_STP# 0 = Free Running, 1 = Stopped with PCI_STP#
2	1	PCIF2	PCIF2 Output Enable 0 = Disabled, 1 = Enabled
1	1	PCIF1	PCIF1 Output Enable 0 = Disabled, 1 = Enabled
0	1	PCIF0	PCIF0 Output Enable 0 = Disabled, 1 = Enabled

Byte 5: Control Register 5

Bit	@Pup	Name	Description
7	1	DOT_48	DOT_48 Output Enable 0 = Disabled, 1 = Enabled
6	1	CPUT3, CPUC3	0 = three-state, 1 = Enabled
5	0	3V66_4/VCH	VCH Select 66 MHz/48 MHz 0 = 3V66 mode, 1 = VCH (48MHz) mode
4	1	3V66_4/VCH	3V66_4/VCH Output Enable 0 = Disabled, 1 = Enabled
3	1	3V66_3	3V66_3 Output Enable 0 = Disabled, 1 = Enabled
2	1	3V66_2	3V66_2 Output Enable 0 = Disabled, 1 = Enabled
1	1	3V66_1	3V66_1 Output Enable 0 = Disabled, 1 = Enabled
0	1	3V66_0	3V66_0 Output Enable 0 = Disabled, 1 = Enabled

Byte 6: Control Register 6

Bit	@Pup	Name	Description
7	0	REF PCIF PCI 3V66 USB_48 DOT_48 CPUT/C SRCT/C	Test Clock Mode 0= Disabled, 1 = Enabled
6	0		Reserved, Set = 0
5	0	CPUC0, CPUT0 CPUC1, CPUT1 CPUC2, CPUT2 CPUC3, CPUT3	FS_A & FS_B Operation 0 = Normal, 1 = Test mode
4	0	SRCT, SRCC	SRC Frequency Select 0 = 100 MHz, 1 = 200 MHz
3	0		Reserved, Set = 0
2	0	PCIF PCI 3V66 SRC(T/C) CPUT/ C	Spread Spectrum Mode 0 = Spread Off, 1 = Spread On
1	1	REF_1	REF_1 Output Enable 0 = Disabled, 1 = Enabled
0	1	REF_0	REF_0 Output Enable 0 = Disabled, 1 = Enabled

Byte 7: Vendor ID

Bit	@Pup	Name	Description
7	0	Revision Code Bit 3	Revision Code Bit 3
6	0	Revision Code Bit 2	Revision Code Bit 2
5	0	Revision Code Bit 1	Revision Code Bit 1
4	0	Revision Code Bit 0	Revision Code Bit 0
3	1	Vendor ID Bit 3	Vendor ID Bit 3
2	0	Vendor ID Bit 2	Vendor ID Bit 2
1	0	Vendor ID Bit 1	Vendor ID Bit 1
0	0	Vendor ID Bit 0	Vendor ID Bit 0

Crystal Recommendations

The CY28419 requires a **Parallel Resonance Crystal**. Substituting a series resonance crystal will cause the CY28419 to operate at the wrong frequency and violate the ppm specification. For most applications there is a 300-ppm frequency shift between series and parallel crystals due to incorrect loading.

Table 6. Crystal Recommendations

Frequency (Fund)	Cut	Loading	Load Cap	Drive (max.)	Shunt Cap (max.)	Motional (max.)	Tolerance (max.)	Stability (max.)	Aging (max.)
14.31818 MHz	AT	Parallel	20 pF	0.1 mW	5 pF	0.016 pF	50 ppm	50 ppm	5 ppm

Crystal Loading

Crystal loading plays a critical role in achieving low ppm performance. To realize low-ppm performance, the total capacitance the crystal will see must be considered to calculate the appropriate capacitive loading (CL).

The following diagram shows a typical crystal configuration using the two trim capacitors. An important clarification for the following discussion is that the trim capacitors are in series with the crystal not parallel. It's a common misconception that load capacitors are in parallel with the crystal and should be approximately equal to the load capacitance of the crystal. This is **not true**.

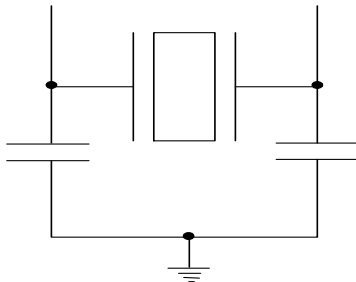

Figure 1. Crystal Capacitive Clarification

Calculating Load Capacitors

In addition to the standard external trim capacitors, trace capacitance and pin capacitance must also be considered to correctly calculate crystal loading. As mentioned previously, the capacitance on each side of the crystal is in series with the crystal. This means the total capacitance on each side of the crystal must be twice the specified crystal load capacitance (CL). While the capacitance on each side of the crystal is in series with the crystal, trim capacitors (Ce1,Ce2) should be calculated to provide equal capacitive loading on both sides.

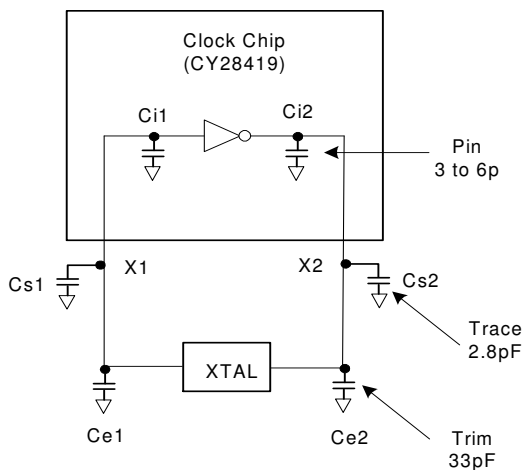

Figure 2. Crystal Loading Example

As mentioned previously, the capacitance on each side of the crystal is in series with the crystal. This means the total capacitance on each side of the crystal must be twice the specified load capacitance (CL). While the capacitance on each side of the crystal is in series with the crystal, trim capacitors (Ce1,Ce2) should be calculated to provide equal capacitive loading on both sides.

Use the following formulas to calculate the trim capacitor values from Ce1 and Ce2.

Load Capacitance (each side)

$$C_e = 2 * CL - (C_s + C_i)$$

Total Capacitance (as seen by the crystal)

$$CL_e = \frac{1}{\left(\frac{1}{C_{e1} + C_{s1} + C_{i1}} + \frac{1}{C_{e2} + C_{s2} + C_{i2}} \right)}$$

- CL.....Crystal load capacitance
- CL_e..... Actual loading seen by crystal
..... using standard value trim capacitors
- C_e..... External trim capacitors
- C_s..... Stray capacitance (trace, etc.)
- C_i Internal capacitance
..... (lead frame, bond wires, etc.)

PD# (Power-down) Clarification

The PD# pin is used to shut off all clocks and PLLs without having to remove power from the device. All clocks are shut down in a synchronous manner so has not to cause glitches while transitioning to the power-down state.

PD#-Assertion

When PD# is sampled low by two consecutive rising edges of the CPUC clock then all clock outputs (except CPU) clocks must be held low on their next high to low transition. CPU clocks must be held with CPUC clock pin driven high with a value of 2x I_{ref} and CPUC undriven as the default condition. There exists an I2C bit that allows for the CPUC/C outputs to be three-stated during power-down. Due to the state of internal logic, stopping and holding the REF clock outputs in the LOW state may require more than one clock cycle to complete.

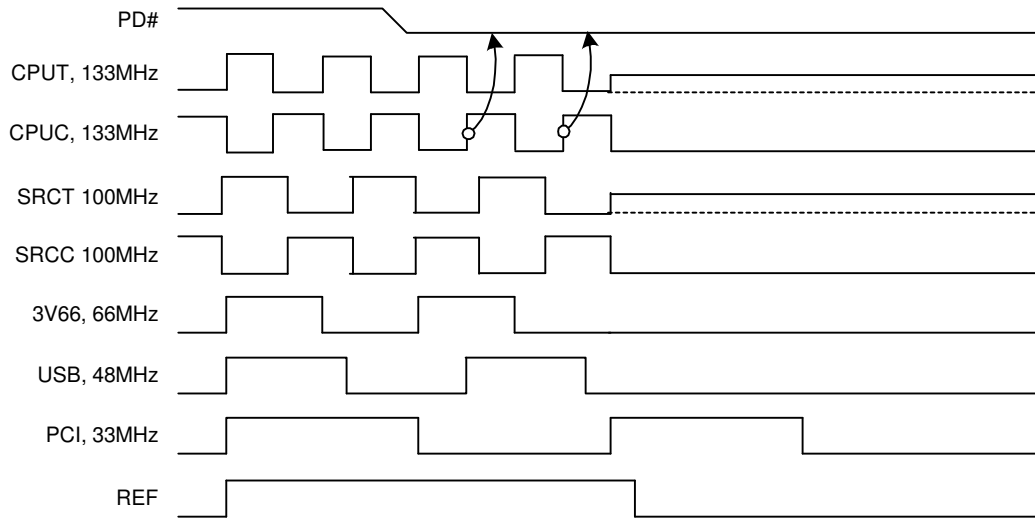

Figure 3. Power-down Assertion Timing Waveforms

PD# Deassertion

The power-up latency between PD# rising to a valid logic '1' level and the starting of all clocks is less than 1.8 ms. The CPU/C outputs must be driven to greater than 200 mV is less than 300 us.

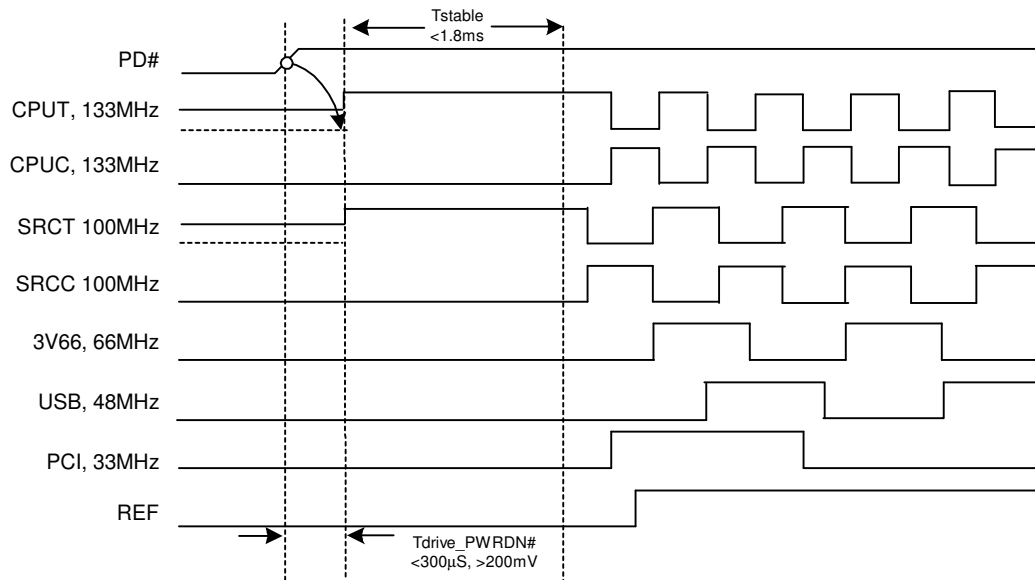
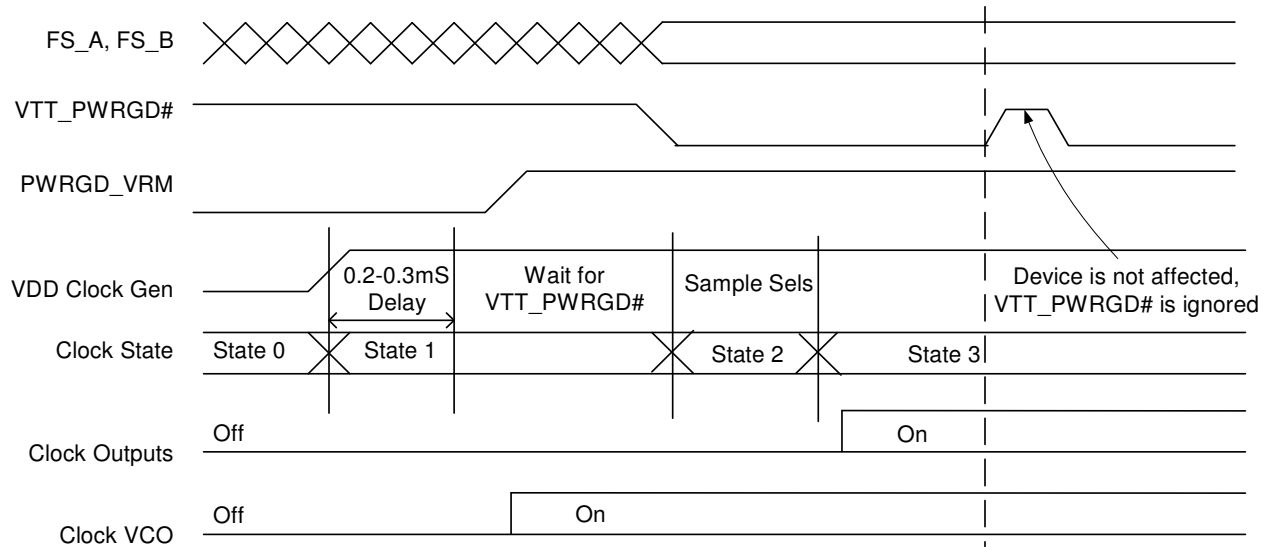
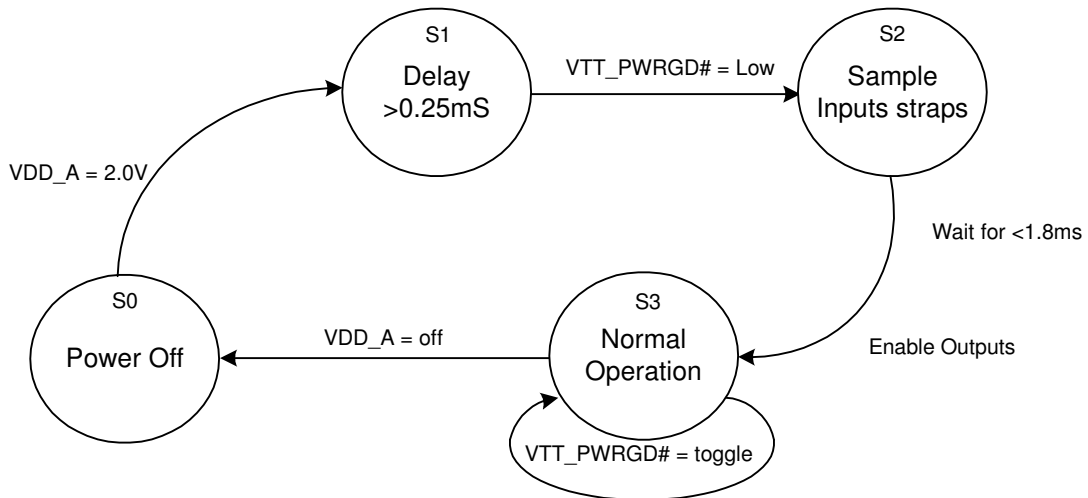

Figure 4. Power-down Deassertion Timing Waveforms

Figure 5. VTT_PWRGD Timing Diagram

Figure 6. Clock Generator Power-up/Run State Diagram

Absolute Maximum Conditions

Parameter	Description	Condition	Min.	Max.	Unit
V _{DD}	Core Supply Voltage		-0.5	4.6	V
V _{DD_A}	Analog Supply Voltage		-0.5	4.6	V
V _{IN}	Input Voltage	Relative to V _{SS}	-0.5	V _{DD} + 0.5	VDC
T _S	Temperature, Storage	Non-functional	-65	+150	°C
T _A	Temperature, Operating Ambient	Functional	0	70	°C
T _J	Temperature, Junction	Functional	-	150	°C
∅ _{JC}	Dissipation, Junction to Case	Mil-Spec 883E Method 1012.1	-	15	°C/W
∅ _{JA}	Dissipation, Junction to Ambient	JEDEC (JESD 51)	-	45	°C/W
ESD _{HBM}	ESD Protection (Human Body Model)	MIL-STD-883, Method 3015	2000	-	V
UL-94	Flammability Rating	At 1/8 in.	V-0		
MSL	Moisture Sensitivity Level		1		

Multiple Supplies: The Voltage on any input or I/O pin cannot exceed the power pin during power-up. Power supply sequencing is NOT required.

DC Electrical Specifications

Parameter	Description	Conditions	Min.	Max.	Unit
V _{DD} , V _{DD_A}	3.3 Operating Voltage	3.3V ± 5%	3.135	3.465	V
V _{IL12C}	Input Low Voltage	SDATA, SCLK	-	1.0	V
V _{IH12C}	Input High Voltage	SDATA, SCLK	2.2	-	V
V _{IL}	Input Low Voltage		V _{SS} - 0.5	0.8	V
V _{IH}	Input High Voltage		2.0	V _{DD} + 0.5	V
I _{IL}	Input Leakage Current	except Pull-ups or Pull-downs 0 < V _{IN} < V _{DD}	-5	5	μA
I _{IH12C}	Input High Voltage	SDATA, SCLK	2.2	-	V
V _{OL}	Output Low Voltage	I _{OL} = 1 mA	-	0.4	V
V _{OH}	Output High Voltage	I _{OH} = -1 mA	2.4	-	V
I _{OZ}	High-impedance Output Current		-10	10	μA
C _{IN}	Input Pin Capacitance		2	5	pF
C _{OUT}	Output Pin Capacitance		3	6	pF
L _{IN}	Pin Inductance		-	7	nH
V _{XIH}	Xin High Voltage		0.7V _{DD}	V _{DD}	V
V _{XIL}	Xin Low Voltage		0	0.3V _{DD}	V
I _{DD}	Dynamic Supply Current	At 200 MHz and all outputs loaded per Table 9 and Figure 7	-	280	mA
I _{PD}	Power-down Supply Current	PD# asserted, Outputs Three-stated	-	1	mA

AC Electrical Specifications

Parameter	Description	Conditions	Min.	Max.	Unit
Crystal					
T _{DC}	XIN Duty Cycle	The device will operate reliably with input duty cycles up to 30/70 but the REF clock duty cycle will not be within specification	47.5	52.5	%
T _{PERIOD}	XIN Period	When XIN is driven from an external clock source	69.841	71.0	ns
T _R / T _F	XIN Rise and Fall Times	Measured between 0.3V _{DD} and 0.7V _{DD}	-	10.0	ns
T _{CCJ}	XIN Cycle-to-Cycle Jitter	As an average over 1-μs duration	-	500	ps
L _{ACC}	Long-term Accuracy	Over 150 ms	-	300	ppm

AC Electrical Specifications (continued)

Parameter	Description	Conditions	Min.	Max.	Unit
CPU at 0.7V					
T _{DC}	CPUT and CPUC Duty Cycle	Measured at crossing point V _{OX}	45	55	%
T _{PERIOD}	100-MHz CPUT and CPUC Period	Measured at crossing point V _{OX}	9.9970	10.003	ns
T _{PERIOD}	133-MHz CPUT and CPUC Period	Measured at crossing point V _{OX}	7.4978	7.5023	ns
T _{PERIOD}	166-MHz CPUT and CPUC Period	Measured at crossing point V _{OX}	5.9982	6.0018	ns
T _{PERIOD}	200-MHz CPUT and CPUC Period	Measured at crossing point V _{OX}	4.9985	5.0015	ns
T _{SKEW}	Any CPU to CPU Clock Skew	Measured at crossing point V _{OX}	–	100	ps
T _{CCJ}	CPU Cycle-to-Cycle Jitter	Measured at crossing point V _{OX}	–	125	ps
T _R /T _F	CPUT/CPUC Rise and Fall Times	Measured from V _{OL} = 0.175 to V _{OH} = 0.525V	175	700	ps
T _{RFM}	Rise/Fall Matching	Determined as a fraction of 2*(T _R -T _F)/(T _R +T _F)	–	20	%
ΔT _R	Rise Time Variation		–	125	ps
ΔT _F	Fall Time Variation		–	125	ps
V _{HIGH}	Voltage High	Math average, see Figure 7	660	850	mv
V _{LOW}	Voltage Low	Math average, see Figure 7	-150	–	mv
V _{OX}	Crossing Point voltage at 0.7V Swing		250	550	mv
V _{OVS}	Maximum Overshoot Voltage		–	V _{HIGH} + 0.3	V
V _{UDS}	Minimum Undershoot Voltage		-0.3	–	V
V _{RB}	Ring Back Voltage	See Figure 7. Measure SE	–	0.2	V
SRC					
T _{DC}	SRCT and SRCC Duty Cycle	Measured at crossing point V _{OX}	45	55	%
T _{PERIOD}	100-MHz SRCT and SRCC Period	Measured at crossing point V _{OX}	9.9970	10.003	ns
T _{PERIOD}	200-MHz SRCT and SRCC Period	Measured at crossing point V _{OX}	4.9985	5.0015	ns
T _{CCJ}	SRC Cycle-to-Cycle Jitter	Measured at crossing point V _{OX}	–	125	ps
L _{ACC}	SRCT/C Long-term Accuracy	Measured at crossing point V _{OX}	–	300	ppm
T _R / T _F	SRCT/SRCTC Rise and Fall Times	Measured from V _{OL} = 0.175 to V _{OH} = 0.525V	175	700	ps
T _{RFM}	Rise/Fall Matching	Determined as a fraction of 2*(T _R -T _F)/(T _R +T _F)	–	20	%
ΔT _R	Rise Time Variation		–	125	ps
ΔT _F	Fall Time Variation		–	125	ps
V _{HIGH}	Voltage High	Math average, see Figure 7	660	850	mv
V _{LOW}	Voltage Low	Math average, see Figure 7	-150	–	mv
V _{OX}	Crossing Point Voltage at 0.7V Swing		250	550	mV
V _{OVS}	Maximum Overshoot Voltage		–	V _{HIGH} +0.3	V
V _{UDS}	Minimum Undershoot Voltage		-0.3	–	V
V _{RB}	Ring Back Voltage	See Figure 7. Measure SE	–	0.2	V
3V66					
T _{DC}	3V66 Duty Cycle	Measurement at 1.5V	45	55	%
T _{PERIOD}	Spread Disabled 3V66 Period	Measurement at 1.5V	14.9955	15.0045	ns
T _{PERIOD}	Spread Enabled 3V66 Period	Measurement at 1.5V	14.9955	15.0799	ns
T _{HIGH}	3V66 High Time	Measurement at 2.0V	4.9500	–	ns
T _{LOW}	3V66 Low Time	Measurement at 0.8V	4.5500	–	ns
T _R / T _F	3V66 Rise and Fall Times	Measured between 0.8V and 2.0V	0.5	2.0	ns
T _{SKEW}	Any 3V66 to Any 3V66 Clock Skew	Measurement at 1.5V	–	250	ps
T _{CCJ}	3V66 Cycle-to-Cycle Jitter	Measurement at 1.5V	–	250	ps

AC Electrical Specifications (continued)

Parameter	Description	Conditions	Min.	Max.	Unit
PCI / PCIF					
T _{DC}	PCIF and PCI Duty Cycle	Measurement at 1.5V	45	55	%
T _{PERIOD}	Spread Disabled PCIF/PCI Period	Measurement at 1.5V	29.9910	30.0009	ns
T _{PERIOD}	Spread Enabled PCIF/PCI Period	Measurement at 1.5V	29.9910	30.1598	ns
T _{HIGH}	PCIF and PCI High Time	Measurement at 2.0V	12.0	–	nS
T _{LOW}	PCIF and PCI Low Time	Measurement at 0.8V	12.0	–	nS
T _R / T _F	PCIF and PCI rise and fall times	Measured between 0.8V and 2.0V	0.5	2.0	nS
T _{SKEW}	Any PCI Clock to Any PCI Clock Skew	Measurement at 1.5V	–	500	pS
T _{CCJ}	PCIF and PCI Cycle-to-Cycle Jitter	Measurement at 1.5V	–	250	ps
DOT					
T _{DC}	DOT Duty Cycle	Measurement at 1.5V	45	55	%
T _{PERIOD}	DOT Period	Measurement at 1.5V	20.8257	20.8340	ns
T _{HIGH}	DOT High Time	Measurement at 2.0V	8.994	10.486	nS
T _{LOW}	DOT Low Time	Measurement at 0.8V	8.794	10.386	nS
T _R / T _F	Rise and Fall Times	Measured between 0.8V and 2.0V	0.5	1.0	ns
T _{LTJ}	Long-term Jitter	10- μ s period	–	2.0	ns
USB					
T _{DC}	USB Duty Cycle	Measurement at 1.5V	45	55	%
T _{PERIOD}	USB Period	Measurement at 1.5V	20.8257	20.8340	ns
T _{HIGH}	USB High Time	Measurement at 2.0V	8.094	10.036	nS
T _{LOW}	USB Low Time	Measurement at 0.8V	7.694	9.836	nS
T _R / T _F	Rise and Fall Times	Measured between 0.8V and 2.0V	1.0	2.0	ns
T _{LTJ}	Long-term Jitter	125- μ s period	–	6.0	ns
REF					
T _{DC}	REF Duty Cycle	Measurement at 1.5V	45	55	%
T _{PERIOD}	REF Period	Measurement at 1.5V	69.827	69.855	ns
T _R / T _F	REF Rise and Fall Times	Measured between 0.8V and 2.0V	1.0	4.0	V/ns
T _{CCJ}	REF Cycle-to-Cycle Jitter	Measurement at 1.5V	–	1000	ps
ENABLE/DISABLE and SET-UP					
T _{STABLE}	Clock Stabilization from Power-up		–	1.8	ms
T _{SS}	Stopclock Set-up Time		10.0	–	ns
T _{SH}	Stopclock Hold Time		0	–	ns

Table 7. Group Timing Relationship and Tolerances

Group	Conditions	Offset	
		Min.	Max.
3V66 to PCI	3V66 Leads PCI	1.5 ns	3.5 ns

Table 8. USB to DOT Phase Offset

Parameter	Typical	Value	Tolerance
DOT Skew	0°	0.0ns	1000 ps
USB Skew	180°	0.0ns	1000 ps
VCH SKew	0°	0.0ns	1000 ps

Table 9. Maximum Lumped Capacitive Output Loads

Clock	Max Load	Unit
PCI Clocks	30	pF
3V66 Clocks	30	pF
USB Clock	20	pF
DOT Clock	10	pF
REF Clock	30	pF

Test and Measurement Set-up

For Differential CPU and SRC Output Signals

The following diagram shows lumped test load configurations for the differential Host Clock Outputs.

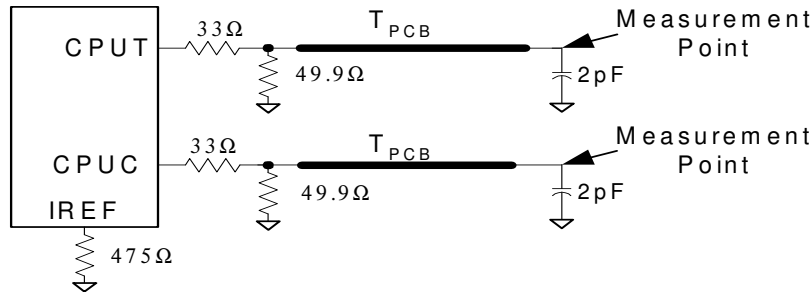

Figure 7. 0.7V Load Configuration

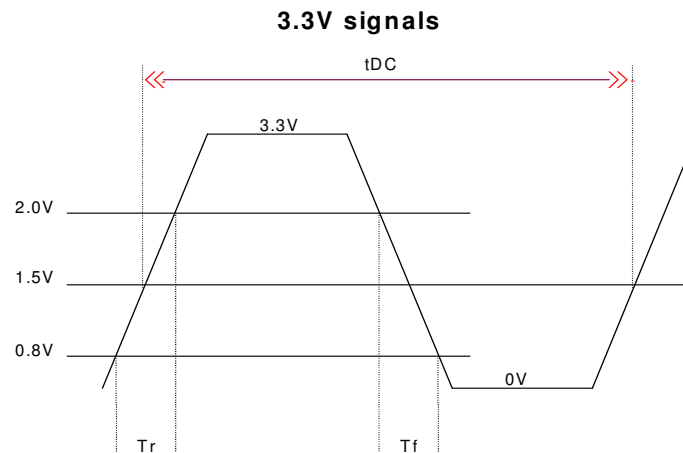

Figure 8. Lumped Load For Single-ended Output Signals (for AC Parameters Measurement)

Table 10. CPU Clock Current Select Function

Board Target Trace/Term Z	Reference R, Iref – V _{DD} (3*Rr)	Output Current	Voh @ Z
50 Ohms	R _{REF} = 475 1%, I _{REF} = 2.32 mA	Ioh = 6*Iref	0.7V @ 50

Ordering Information

Part Number	Package Type	Product Flow
CY28419OC	56-pin Shrunk Small Outline package (SSOP)	Commercial, 0° to 70°C
CY28419OCT	56-pin Shrunk Small Outline package (SSOP) – Tape and Reel	Commercial, 0° to 70°C
CY28419ZC	56-pin Thin Shrunk Small Outline package (TSSOP)	Commercial, 0° to 70°C
CY28419ZCT	56-pin Thin Shrunk Small Outline package (TSSOP) – Tape and Reel	Commercial, 0° to 70°C
Part Number	Package Type - Lead Free	Product Flow
CY28419OXC	56-pin Shrunk Small Outline package (SSOP)	Commercial, 0° to 70°C
CY28419OXCT	56-pin Shrunk Small Outline package (SSOP) – Tape and Reel	Commercial, 0° to 70°C
CY28419ZXC	56-pin Thin Shrunk Small Outline package (TSSOP)	Commercial, 0° to 70°C
CY28419Z XCT	56-pin Thin Shrunk Small Outline package (TSSOP) – Tape and Reel	Commercial, 0° to 70°C

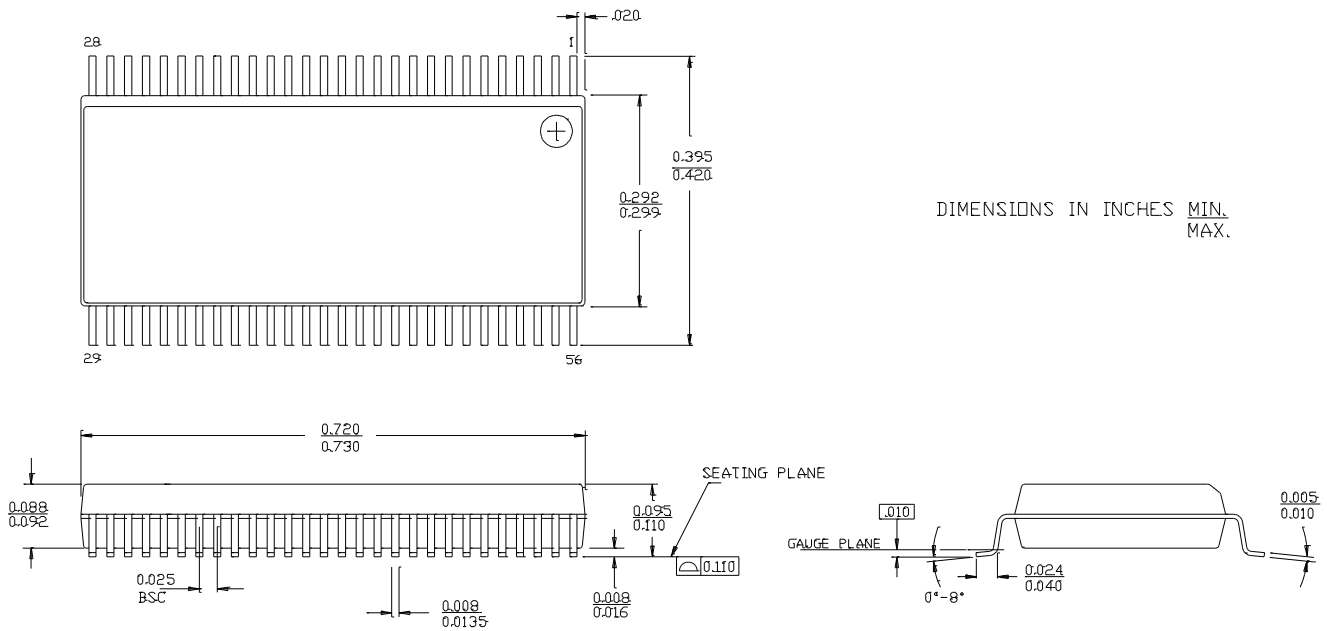
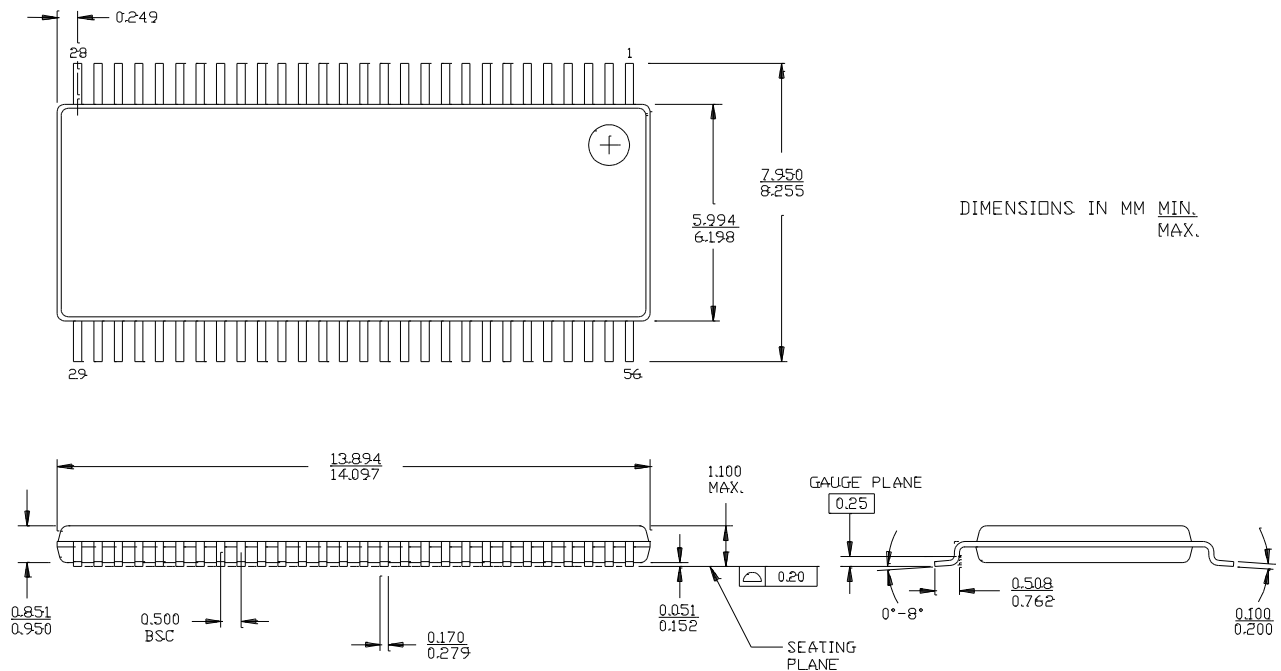
Package Drawing and Dimensions
56-Lead Shrunk Small Outline Package O56

56-Lead Thin Shrunk Small Outline Package, Type II (6 mm x 14 mm) Z56

While SLI has reviewed all information herein for accuracy and reliability, Spectra Linear Inc. assumes no responsibility for the use of any circuitry or for the infringement of any patents or other rights of third parties which would result from each use. This product is intended for use in normal commercial applications and is not warranted nor is it intended for use in life support, critical medical instruments, or any other application requiring extended temperature range, high reliability, or any other extraordinary environmental requirements unless pursuant to additional processing by Spectra Linear Inc., and expressed written agreement by Spectra Linear Inc. Spectra Linear Inc. reserves the right to change any circuitry or specification without notice.