

DESCRIPTION

Demonstration Circuit 565 is a constant-frequency synchronous boost converter using the LTC3421. Guaranteed to start-up at 1V input voltage, this converter provides up to 95% efficiency. For 1.8V minimum input voltage, this converter can provide up to 1A load current.

This converter has true output disconnect by eliminating body diode conduction of the internal PMOS rectifier. This feature reduces the inrush current during start-up and isolates the load from input source in shutdown to eliminate any leakage current. With the V_{REF} output and low-battery comparator disabled, the IC only draws less than 1 μ A in shutdown.

The output voltage is set at 3.3V. A different output voltage in the range of 2.4V to 5.25V can be obtained by changing one of the feedback resistors. The switching frequency is set at 1MHz, which is a good trade-off between efficiency and size. The frequency can be adjusted by selecting R13 at R_T pin. It can also be synchronized to an external clock for noise-sensitive applications.

Long wires from input sources (such as wall adaptors) can cause large voltage spikes during initial plug-in. C12 is installed on DC565 to damp the possible voltage spikes. C12 is not required for applications where input source is close to the regulator. Please refer to Application Note 88 for details.

For $V_{OUT} > 4.3V$ applications, D1, Q1, R18 and C10 have to be installed to limit the peak switch voltage below the absolute maximum rating. Instead of using a schottky diode connected directly from SW pin to the output, this active snubber keeps the LTC3421 true output disconnect feature. R18 can be used to limit the current going through Q1 in short-circuit conditions.

The optional circuit at ILIM pin can be added to provide current limit foldback for extended short-circuit conditions. Refer to Short Circuit section in the datasheet for details.

Design files for this circuit board are available. Call the LTC factory.

Table 1. Performance Summary ($T_A = 25^\circ C$ unless otherwise noted)

PARAMETER	CONDITION	VALUE	
Minimum Input Voltage		1V	
Output Voltage V_{OUT}	$V_{IN} = 1.8V$ to $3.2V$, $I_{OUT} = 0A$ to $1A$	$3.3V \pm 3\%$	
Maximum Output Current	$V_{IN} = 1.8V$ to $3.2V$	1A	
Typical Output Ripple V_{OUT}	$V_{IN} = 2.4V$, $I_{OUT} = 1A$ (20MHz BW)	30mV _{P-P}	
Typical Switching Frequency		1MHz	
Efficiency	$V_{IN} = 2.4V$, $I_{OUT} = 0.2A$	95% Typical	
	$V_{IN} = 2.4V$, $I_{OUT} = 1A$	88% Typical	
On/Off Control	Logic Low Voltage-Off	0.25V MAX	
	Logic High Voltage-On	$V_{OUT} = 0V$	1V MIN
		$V_{OUT} > 2.4V$	0.6V MIN

QUICK START PROCEDURE

Demonstration circuit 565 is easy to set up to evaluate the performance of the LTC3421. Refer to Figure 1 for proper measurement equipment setup and follow the procedure below:

NOTE: When measuring the input or output voltage ripple, care must be taken to avoid a long ground lead on the oscilloscope probe. Measure the input or output voltage ripple by touching the probe tip directly across the Vin or Vout and GND terminals. See Figure 2 for proper scope probe technique.

1. Place jumpers in the following positions:

JP1 ON or OFF
JP2 RUN
JP3 AUTO ON

2. With power off, connect the input power supply to Vin and GND.

3. Turn on the power at the input.

NOTE: Make sure that the input voltage does not exceed 3.3V.

4. Check for the proper output voltage. $V_{out} = 3.2V$ to $3.4V$.

NOTE: If there is no output, temporarily disconnect the load to make sure that the load is not set too high.

5. Once the proper output voltage is established, adjust the load within the operating range and observe the output voltage regulation, ripple voltage, efficiency and other parameters.

GRAPHICS

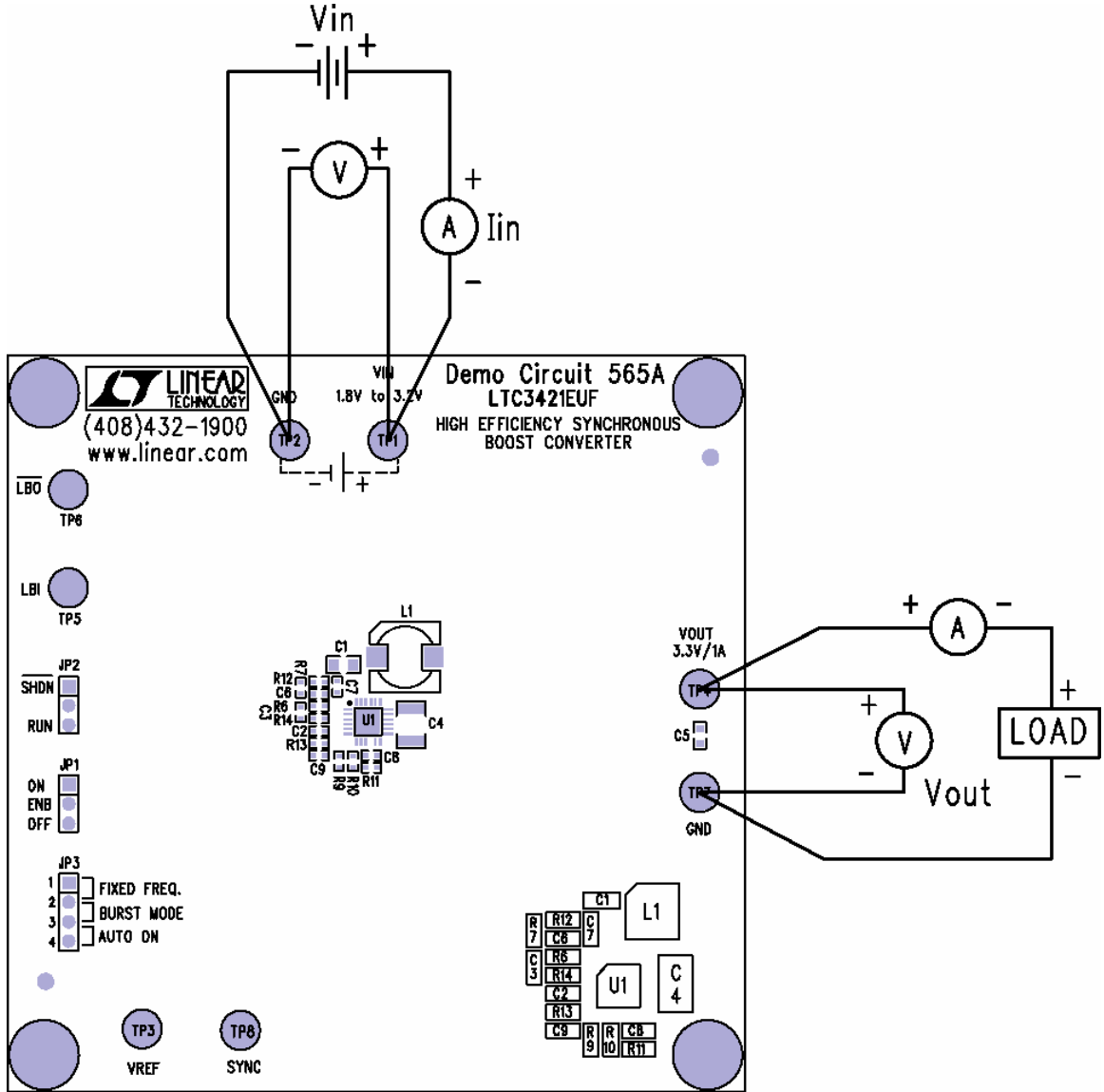

Figure 1. Proper Measurement Equipment Setup

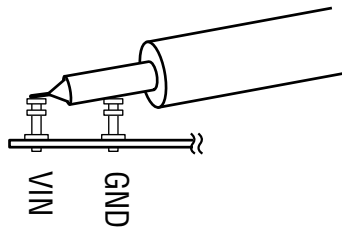

Figure 2. Measuring Input or Output Ripple

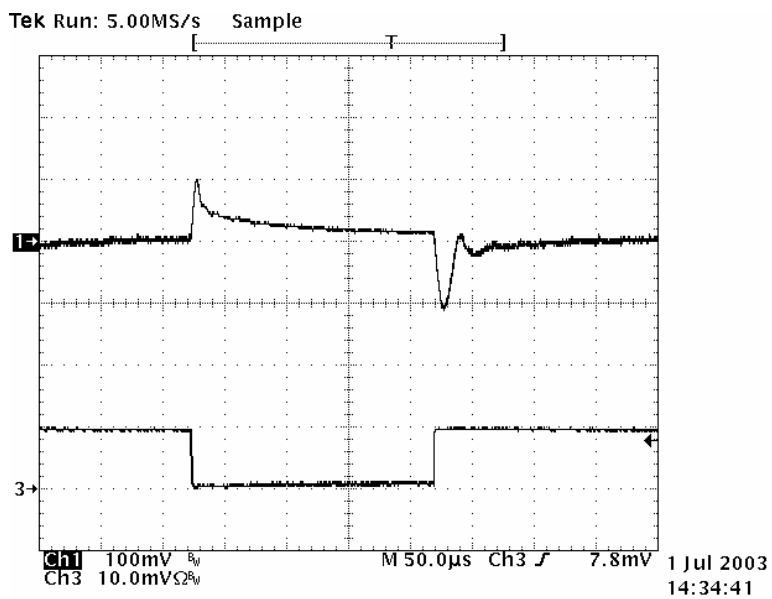
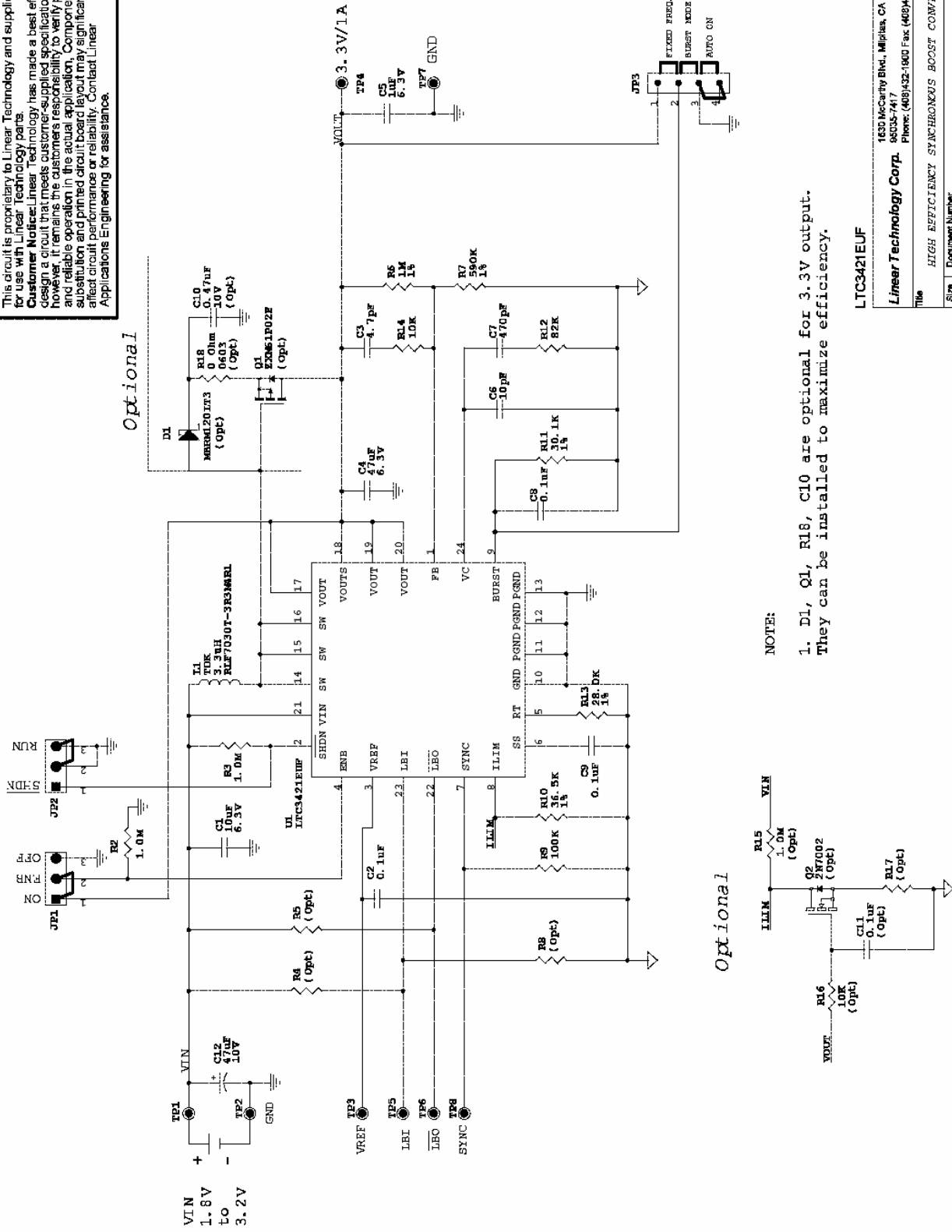

Figure 3. Load Transient Response (Vin=3V; Channel 1: Vout; Channel 2: Iout: load step from 100mA to 1A)

This circuit is proprietary to Linear Technology and supplied for use with Linear Technology parts.
Customer Notice: Linear Technology has made a best effort to design a circuit that meets customer-supplied specifications; however, it remains the customer's responsibility to verify proper and reliable operation in the actual application. Component substitution and printed circuit board layout may significantly affect circuit performance or reliability. Contact Linear Applications Engineering for assistance.



NOTE:

1. D1, Q1, R18, C10 are optional for 3.3V output. They can be installed to maximize efficiency.

LTC3421EUF

Linear Technology Corp.
 1630 McCarthy Blvd., Milpitas, CA
 95035-7417
 Phone: (408)432-1900 Fax: (408)432-0507

Title		HIGH EFFICIENCY SYNCHRONOUS BOOST CONVERTER	
Size	Document Number	Demo Circuit 565	
Date	Fr.-day	Oct-Nov	22, 2001
Sheet	1	of	1
Rev	A		