

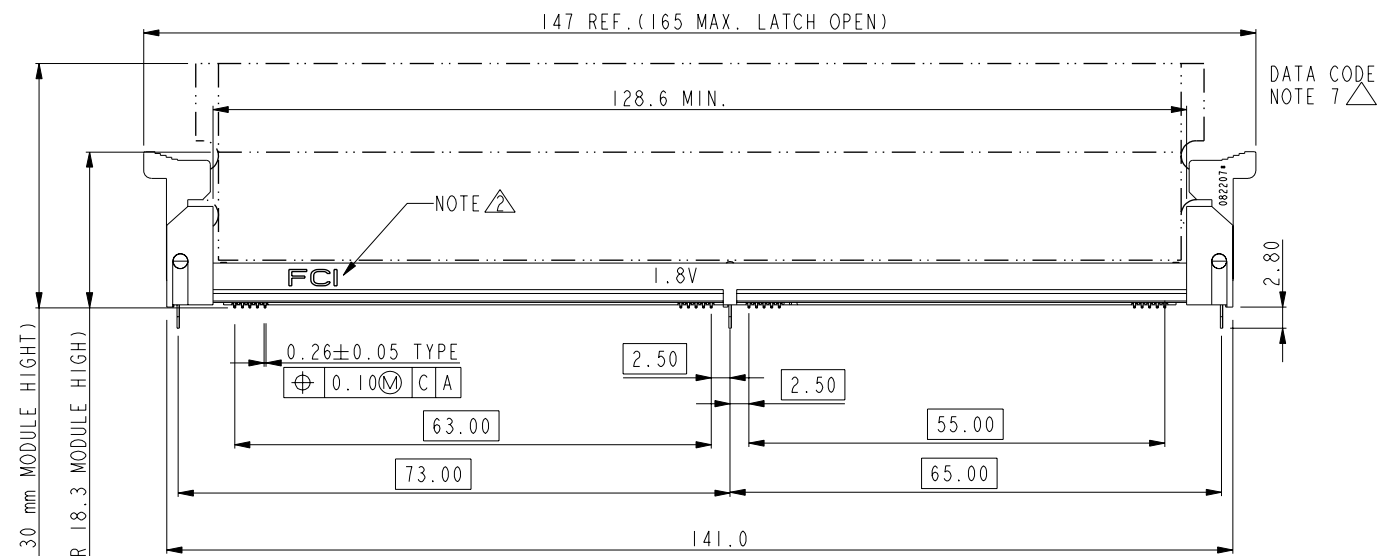

Copyright FCI.

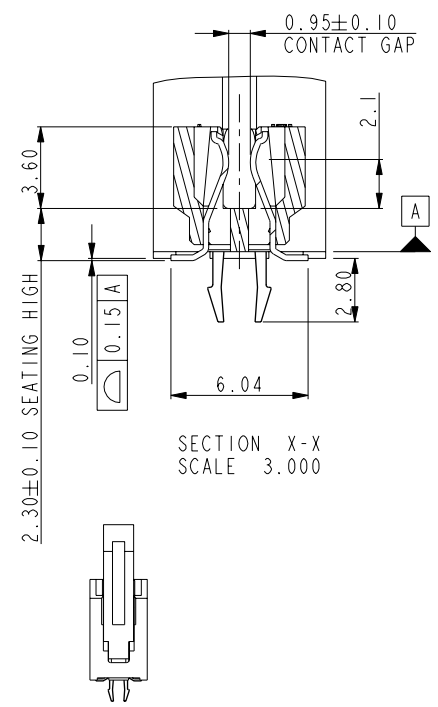
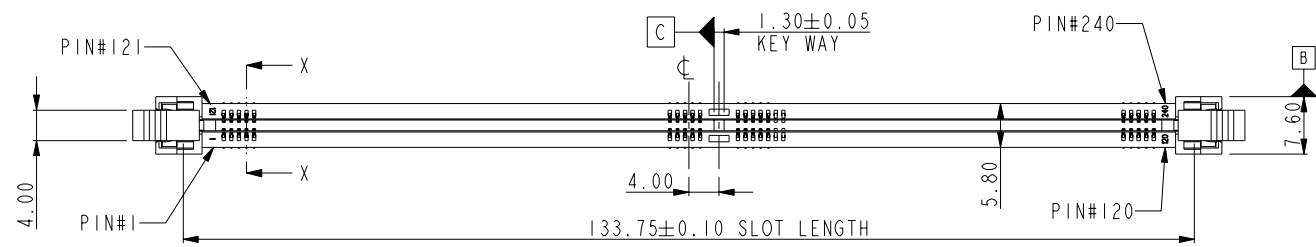

32.30 REF. (FOR 30 mm MODULE HEIGHT)
 20.6 REF. (FOR 18.3 MODULE HIGH)

SCALE 1.000

rev	ecn no	dr	date
A	DG07-0466	CS	11/22/07'
B	DG08-0248	BL	09/10/08'
C	DG09-0040	BL	02/19/09'
D	DG09-0094	BL	03/26/09'
E	N10-0076	R.B	2010-04-30

www.fciconnect.com		surface <input checked="" type="checkbox"/>	tolerance std	projection	MM
		TOLERANCES UNLESS OTHERWISE SPECIFIED			
Dr	MAGGIE WU	07/14/06	ANGULAR	size	Scale
Eng	GARY HSIEH	07/14/06	LINEAR	A4	0.707
Chr	PAUL WANG	07/14/06	0° ±°	ECN	N10-0076
Appr	JOSEPH HSIA	07/14/06	Product family	Spec ref	*
FCI		title		dwg no	Rev.
		SMT TYPE DDR II ASS'Y		10080289	E
		DDR II 240P		CUSTOMER	sheet 1 of 4
		catalog no			

REV F - 2006-04-11



Copyright FCI.

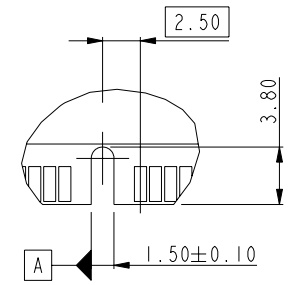
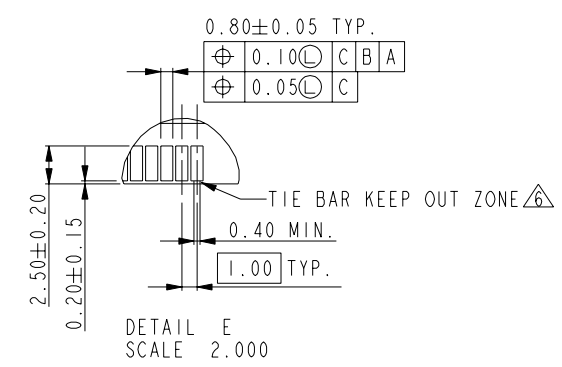
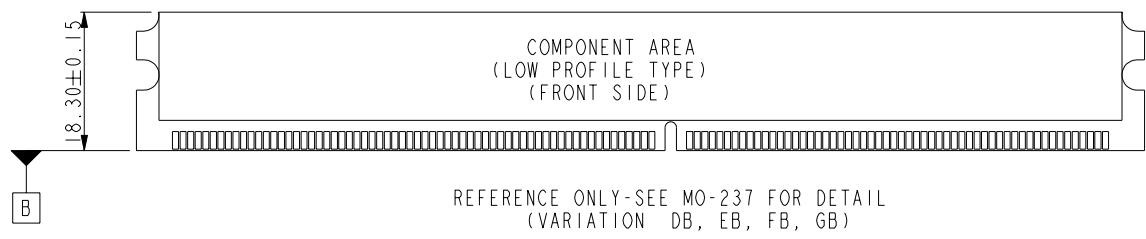
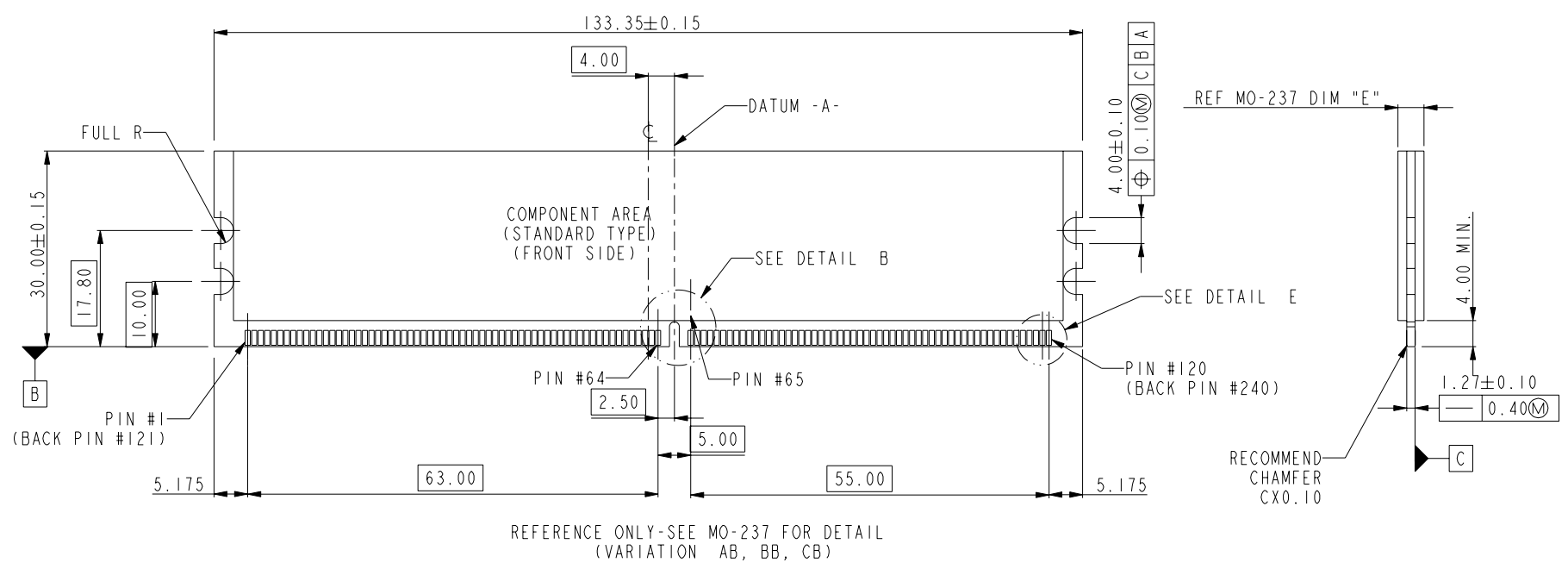

	title	SMT TYPE DDR II ASS'Y	dwg no	10080289	Rev.	E
		DDR II 240P				
	catalog no	-	CUSTOMER	sheet 2 of 4		

REV F - 2006-04-11



Copyright FCI.

A
B
C
D

A
B
C
D

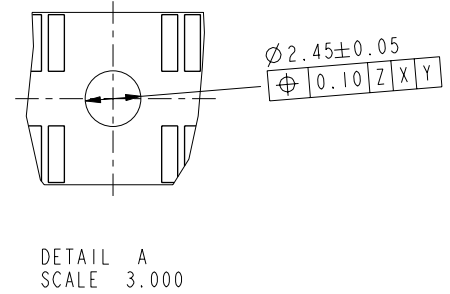
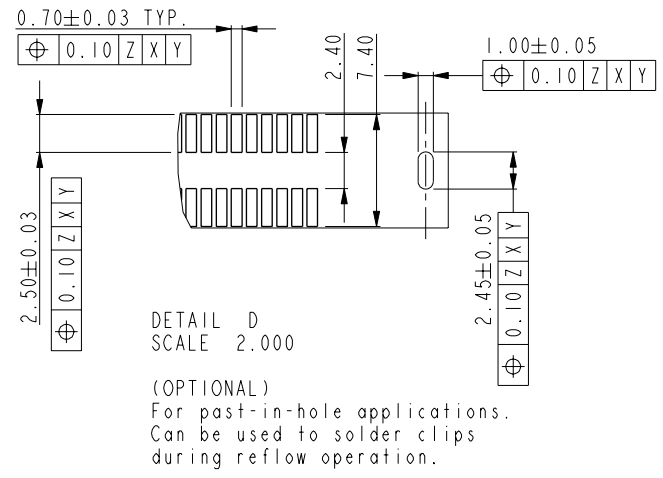
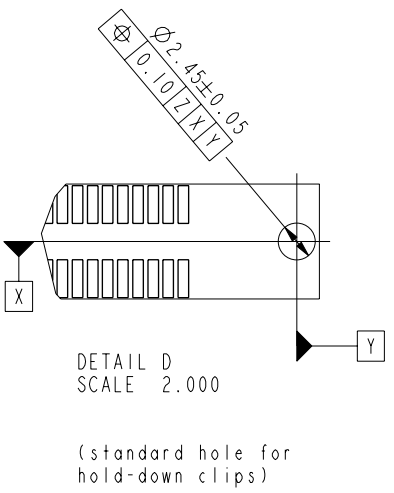
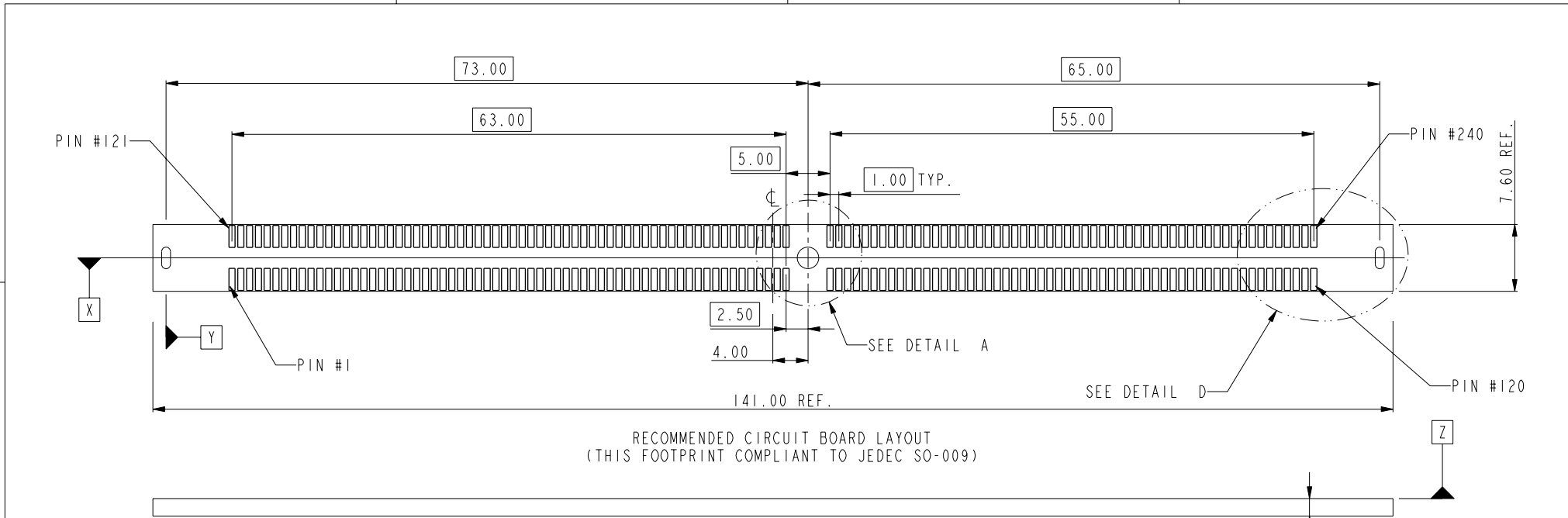

PCB THK±0.15 mm



title	SMT TYPE DDR II ASS'Y		dwg no	10080289	Rev.	E
	DDR II 240P					
catalog no	-	CUSTOMER	sheet 3 of 4			

10080289 - □ □ □ □

STYLE : MECHANICAL KEYING

1 : 1.8 VOLT. W/ CENTER KEY

HOLD DOWN TYPE

0 : THREE FORK HOLD DOWN TYPE

PLATING

CODE	CONTACT	SOLDERTAIL	UNDERPLATE
1LF	10u" (0.25um) MIN. GOLD	100u" (2.54um) MIN. 100% MATT TIN	50u" (1.27um) MIN. NICKEL OVERALL
2LF	15u" (0.38um) MIN. GOLD		
3LF	30u" (0.76um) MIN. GOLD		
4LF	GOLD FLASH		

RESERVED

0

COLOR OF HOUSING AND EJECTOR

0 : BLACK HOUSING + IVORY EJECTOR

NOTES:

- MATERIAL:
HOUSING: HIGH PERFORMANCE RESINS, GLASS FILLED UL94V-0 RATED.
EJECTOR: HIGH PERFORMANCE RESINS, GLASS FILLED UL94V-0 RATED.
TERMINAL: HIGH PERFORMANCE COPPER ALLOY
METAL CLIP: COPPER ALLOY.
- FCI LOGO TO BE APPROXIMATELY LOCATED AS SHOWN ON PRINT.
- PRODUCT SPECIFICATION: GS-12-251.
- PACKAGING SPECIFICATION: GS-14-899.
- RECOMMENDED STENCIL THICKNESS NO LESS THAN 0.15 mm.
- FOR OPTIMUM PERFORMANCE, THE TIE BAR IS TO BE ON AN INTERNAL LAYER SO THAT THE REMNANT CANNOT CAUSE CONTACT DAMAGE.
- THE DATE CODE IS SHOWN "MM-DD-YY*": "*" MEANS PRODUCTION LINE.
- THIS PRODUCT MEETS EUROPEAN UNION DIRECTIVES AND OTHER COUNTRY REGULATIONS AS DESCRIBED IN GS-22-008.
- THE HOUSING WILL WITH STAND EXPOSURE TO 260°C PEAK TEMPERATURE FOR 10 SECONDS IN AN IR REFLOW SOLDERING APPLICATION.
- PRODUCT APPLICATION SPEC GS-20-089.



Copyright FCI.



title	SMT TYPE DDR II ASS'Y	dwg no	10080289	Rev.	E
	DDR II 240P				
catalog no	-	CUSTOMER	sheet 4 of 4		