

PART NUMBER	REVISION	DESCRIPTION	FEED TYPE
2150150-1	H	FINE CRIMP HEIGHT ADJUST	MECHANICAL
2150150-2	J	FINE CRIMP HEIGHT ADJUST	PNEUMATIC
7-2150150-1	H	MECHANICAL AND CRIMP TOOLING KIT	MECHANICAL
7-2150150-2	J	PNEUMATIC AND CRIMP TOOLING KIT	PNEUMATIC
7-2150150-7	A	CRIMP TOOLING KIT	-

ATLANTIC VERSION TERMINATOR INTERFACE ADAPTER

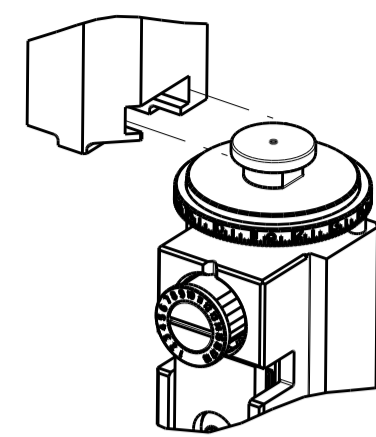

APPLICATOR DATA		
CRIMP	SIZE	TYPE
WIRE	1.57 mm [.062]	○
NOSE	1.57 mm [.062]	○

APPLICATOR INSTRUCTIONS 408-35043

TERMINAL DATA: TE TERMINAL TE CRIMP SPECIFICATION			
TERMINAL NAME: CIRCULAR WIRE PIN			
WIRE STRIP LENGTH	INSULATION DIAMETER RANGE		
7.54-8.33 mm [.297-.328 IN]	-		
TERMINAL APPLICATION SPECIFICATION	NONE	-	-
TERMINALS APPLIED			
TE TERMINAL	TE TERMINAL	TE TERMINAL	TE TERMINAL
926933-1	926933-3	926933-6	926933-8
926933-2	926933-4	926933-7	926933-9



WIRE SIZE	WIRE CRIMP HEIGHT mm [INCH]	WIRE CRIMP HEIGHT REFERENCE SETTING	NOSE CRIMP HEIGHT	NOSE CRIMP HEIGHT REFERENCE SETTING
1.00mm2	1.55+/-0.05 [.061+/-0.002]	8	1.76+/-0.05 [.069+/-0.002]	5.1
0.75mm2	1.45+/-0.05 [.057+/-0.002]	7	1.65+/-0.05 [.065+/-0.002]	6.2
0.50mm2	1.14+/-0.05 [.045+/-0.002]	12	1.55+/-0.05 [.061+/-0.002]	7.6

- 1 RECOMMENDED SPARE PARTS
- 2 REFER TO SUPPLIED INSTRUCTION SHEET FOR CLEANING, LUBRICATION AND STORAGE OF APPLICATOR.
- 3 APPLY PART NUMBER 2-23419-6 LOCTITE TO THREADS OF ITEM 242.
- 4 CRIMP HEIGHT REFERENCE SETTING WAS THE SETTING USED WHEN THE APPLICATOR WAS QUALIFIED AT THE FACTORY. ADJUSTMENT MAY BE NECESSARY WHEN RUNNING APPLICATOR IN THE FIELD.
- 5 TERMINAL LUBRICANT IS RECOMMENDED.
- 6. UNLESS SPECIFIED OTHERWISE TORQUE VALUES SHALL BE USED PER DOCUMENT, 101-35000.
- 7 CRIMP HEIGHTS FOR WIRE BARRELS ONLY. ADJUST ITEM 244 TO OBTAIN WIRE CRIMP HEIGHT.
- 8 WIRE SIZE APPLIES ONLY FOR HANDBRAKE CONTACT REFER TO BMW DRAWING 6 928 203.
- 9 ITEM 244 ADJUSTS WIRE CRIMP HEIGHT. THE WIRE CRIMP HEIGHT ADJUST DIAL ADJUSTS INSULATION (NOSE) CRIMP HEIGHT.
- 10 POSITION ITEM 27 IN FRONT OF ITEM 77.

***WARNING**
ON INSTALLATION, SET WIRE DISC TO CRIMP HEIGHT REFERENCE SETTING FOR LARGEST WIRE SIZE. CRIMP HEIGHT REFERENCE SETTINGS GREATER THAN THE VALUE SHOWN MAY CAUSE DAMAGE TO THE CRIMP TOOLING. REFER TO THE INSTRUCTION SHEET FOR PROPER SETUP AND ADJUSTMENTS.

LOC	DIST	REVISIONS			
A	66	REV	DATE	BY	APPV
		F	09OCT2018	TB	TE
		G	02MAY2019	TB	TE
		H	26FEB2020	JWC	GB
		J	12OCT2020	FJ	TE

-	1	-	1	-	2119641-1	FEED CAM, AIR FEED	248	
7	-	1	1	1	2119082-2	CAM, SNAIL, INSULATION ADJUSTMENT	244	
-	1	1	1	1	2079764-1	WASHER, WAVE SPRING, CREST-TO-CREST	243	
3	-	1	1	1	2119083-1	RETAINER, INSULATION DIAL	242	
-	-	1	-	1	2119580-1	MECHANICAL FEED ASSEMBLY	239	
-	1	-	1	-	2844940-3	AIR FEED MODULE	238	
-	1	1	1	1	1803071-1	SPACER, REAR SHEAR STRIP GUIDE	196	
-	1	1	1	1	3-459722-7	BLADE, SHEAR	195	
5	-	REF	REF	REF	994970-2	COUNTER, MAGNETIC	164	
-	1	1	1	1	2119955-2	ASSY, LUBRICATOR, END FEED	84	
-	1	1	1	1	455888-4	SPACER, CRIMPER	82	
-	1	1	1	1	1803203-2	BLOCK, FRONT DEPRESSOR	77	
-	1	1	1	1	2119791-9	DEPRESSOR, WIRE	73	
-	1	1	1	1	1803607-4	DOCUMENTATION PACKAGE	71	
-	2	2	2	2	2-18032-2	SCR, SET, FLT PNT, M3 X 10.0	70	
-	1	1	1	1	2119740-1	TAG, IDENTIFICATION	67	
-	2	2	2	2	2168078-1	SCREW, DRIVE, RH, RoHS, 2 x .188	66	
-	2	2	2	2	2168400-8	SHCS, LOW HEAD, RoHS, M4 X 16	64	
-	1	1	1	1	5-18022-5	SCR, HEX HD CAP, M4 X 6.0	59	
-	-	1	-	1	2063961-1	FEED FINGER	58	
-	3	3	3	3	2168400-4	SHCS, LOW HEAD, RoHS, M4 X 8	57	
-	2	2	2	2	5018030-1	NUT, HEX, REG, RoHS, M3	54	
-	2	2	2	2	986965-8	NUT, LOCK, HEX, TORQUE (M4)	53	
-	1	-	1	-	2063961-9	FEED FINGER	51	
-	1	2	1	2	18023-9	SCR, SKT HD CAP M4 X 6.0	49	
-	-	1	-	1	2119652-1	FEED CAM, PRE FEED	48	
-	-	1	-	1	2119653-1	FEED CAM, POST FEED	47	
-	1	1	1	1	3-2119655-1	APPLICATOR BASIC ASSEMBLY, EF	46	
-	1	1	1	1	1803517-1	RAM ASSEMBLY, EF ATLANTIC	44	
-	1	1	1	1	1803602-1	SCR, BHSC, RoHS (M8 X 25)	41	
-	7	7	7	7	1-18028-2	WASHER, FLAT, REG M4	33	
-	2	2	2	2	1-2168083-2	SCR, SKT HD CAP, RoHS, M4 X 25	31	
-	2	2	2	2	2168083-2	SCR, SKT HD CAP, RoHS, M4 X 8.0	29	
10	-	1	1	1	690455-1	STRIPPER, FRONT CASTING	27	
-	2	2	2	2	1-2168083-5	SCR, SKT HD CAP, RoHS, M4 X 30	25	
-	1	1	1	1	1752371-5	PLATE, STRIP GUIDE	24	
-	1	1	1	1	240825-1	PLATE, STRIP HOLD DOWN	23	
-	2	2	2	2	2-22281-3	SPRING, COMPRESSION	22	
-	1	1	1	1	1803292-4	DRAG	20	
-	2	2	2	2	1901259-4	GUIDE, LOWER STRIP	18	
-	4	4	4	4	1-2079383-1	SCR, BHSC, RoHS (M6 X 12)	17	
1	-	1	1	1	2-240644-5	PLATE, REAR SHEAR	11	
-	2	2	2	2	6-240645-5	SPACER, SHEAR PLATE	10	
1	1	2	2	1	1633342-5	ANVIL, WIRE	8	
-	1	1	1	1	238011-3	BLOCK, CRIMPER SPACER	4	
1	1	2	2	1	5-2119784-6	CRIMPER, INSULATION O PREMIUM	3	
1	1	2	2	1	6-459492-8	CRIMPER, WIRE O	1	
-	77	72	71	2	-1	PART NO	DESCRIPTION	ITEM NO

ATLANTIC VERSION
Shown on sheets 1 of 4 & 2 of 4
(Pacific version shown on sheets 3 of 4 & 4 of 4)

DIMENSIONS: mm		TOLERANCES UNLESS OTHERWISE SPECIFIED:		DWG: HOFFNER 12JUN2012		CHK: T. ELBIN 13JUN2012		APVD: T. ELBIN 13JUN2012		NAME: Ocean End Feed Applicator	
0 PLC ±		1 PLC ±		2 PLC ±		3 PLC ±		4 PLC ±		SIZE: A1	
ANGLES		FINISH		WEIGHT		SCALE: 1:1		SHEET: 1 of 4		REV: J	
MATERIAL		FINISH		WEIGHT		SCALE: 1:1		SHEET: 1 of 4		REV: J	

LOC	DIST	REV	DATE	BY	APPV
A	66				
REVISIONS			DESCRIPTION	DATE	BY
-			SEE SHEET 1	-	-

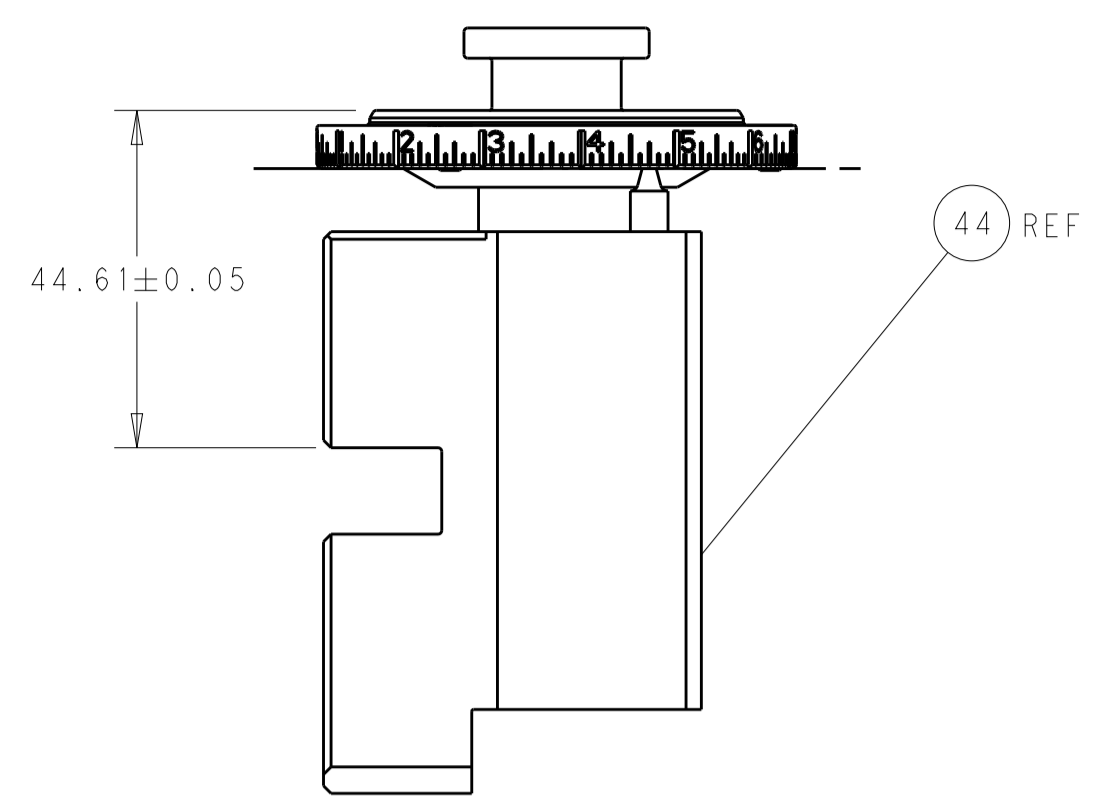

RAM SET-UP

FEED TYPE MECHANICAL

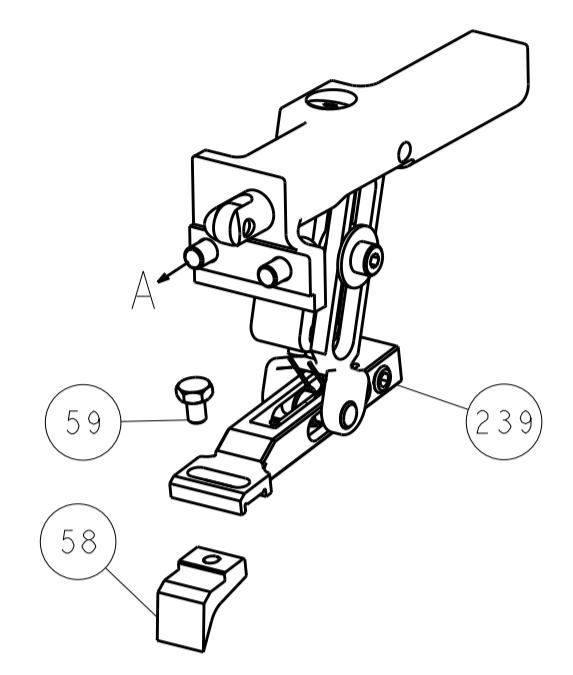

PNEUMATIC

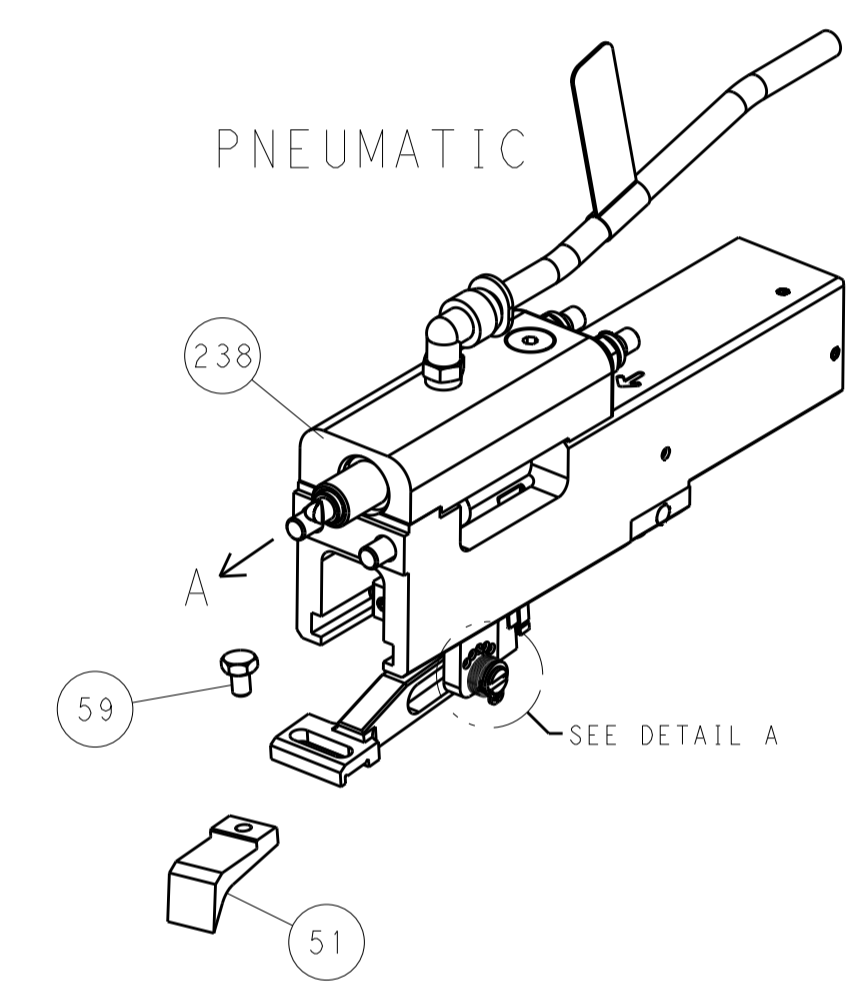

FEED SPRING SETTING POSITION

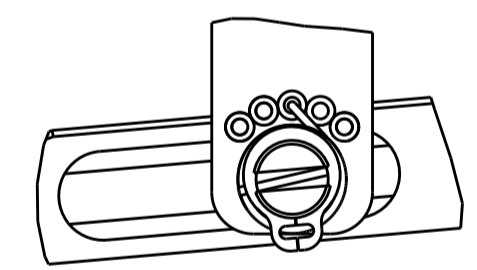

DETAIL A

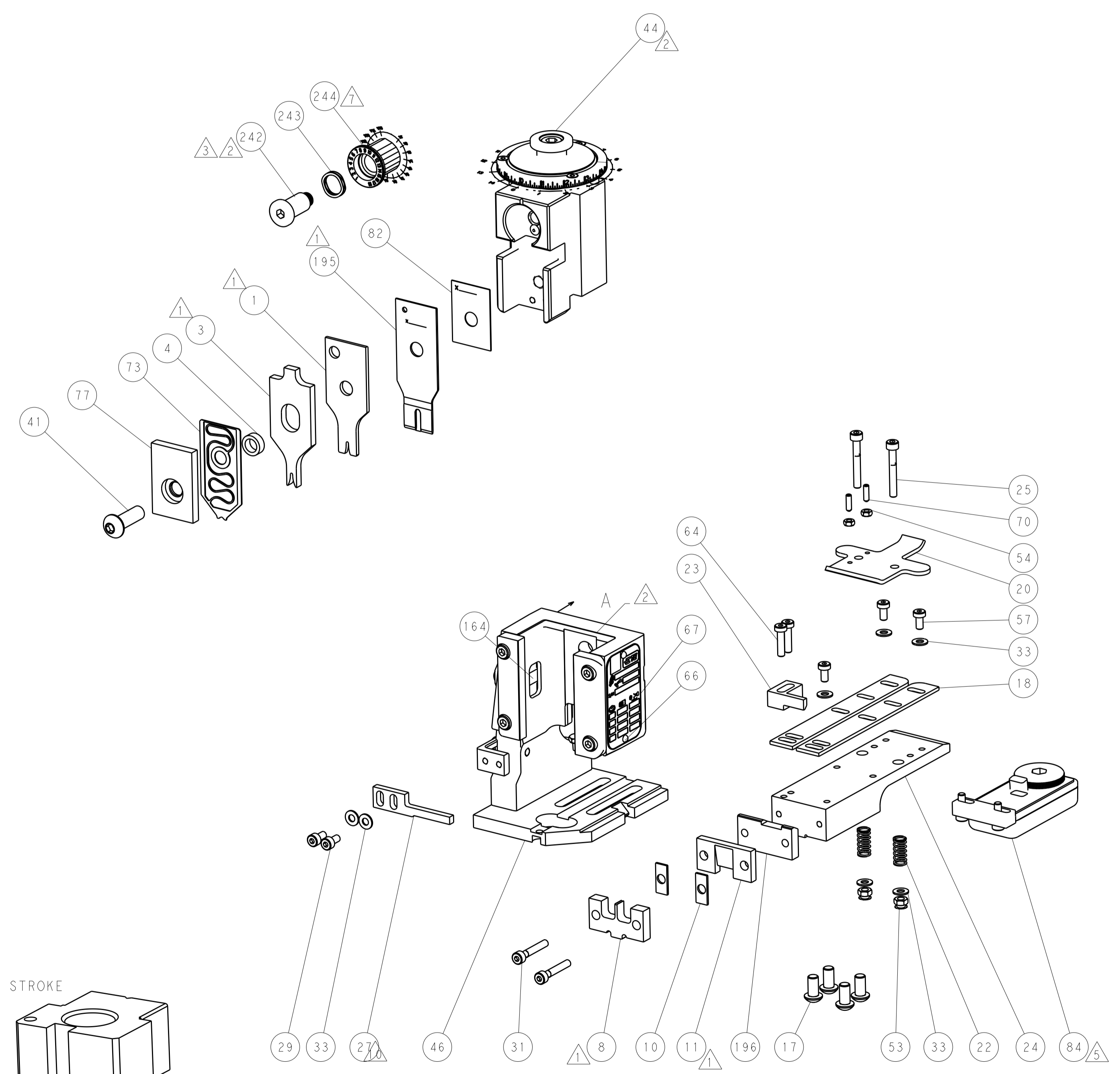

CAM POSITIONS

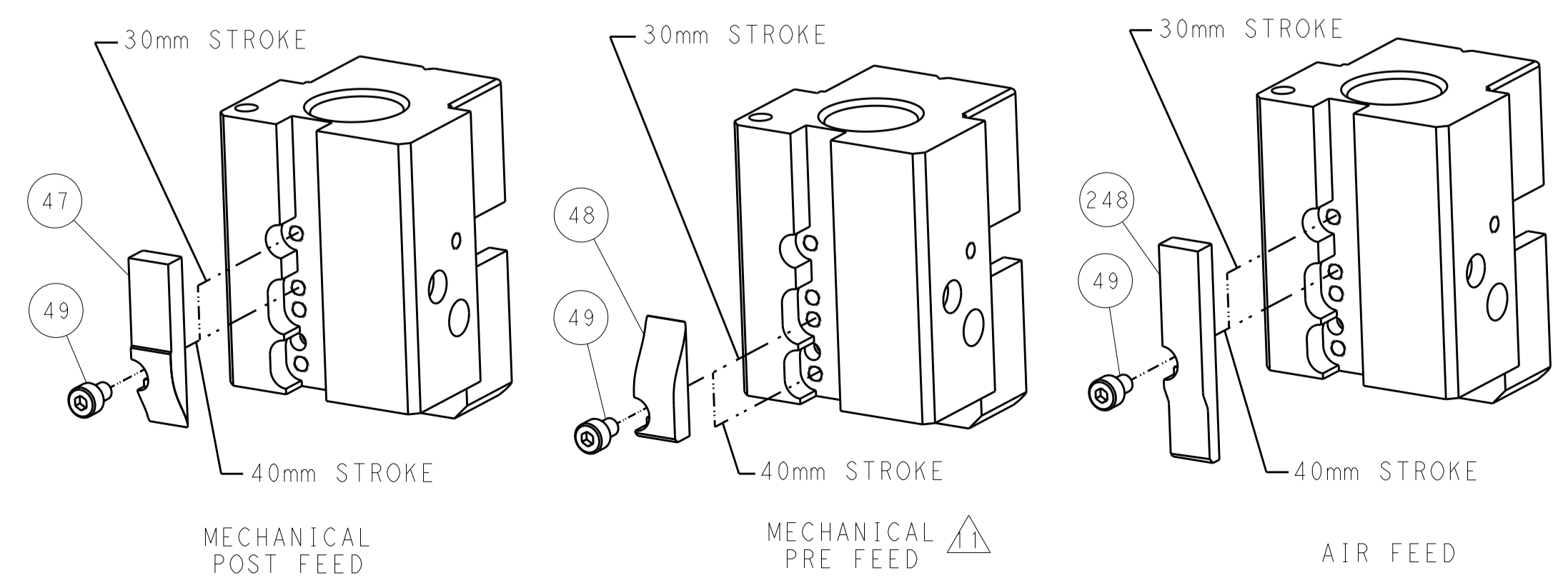

ATLANTIC VERSION
 Shown on sheets 1 of 4 & 2 of 4
 (Pacific version shown on sheets 3 of 4 & 4 of 4)

<small>THIS DRAWING IS UNPUBLISHED. RELEASED FOR PUBLICATION BY TYCO ELECTRONICS CORPORATION. ALL RIGHTS RESERVED.</small>		DWN: HOFFNER 12JUN2012 CHK: T. ELBIN 13JUN2012 APVD: T. ELBIN 13JUN2012	TE Connectivity Harrisburg, PA 17105-3608
DIMENSIONS: mm TOLERANCES UNLESS OTHERWISE SPECIFIED: 0 PLC ± 1 PLC ± 2 PLC ± 3 PLC ± 4 PLC ± ANGLES ± MATERIAL: - FINISH: -		NAME: Ocean End Feed Applicator SIZE: A1 CAGE CODE: 00779 DRAWING NO: 2150150	RESTRICTED TO: - SCALE: 1:1 SHEET: 2 of 4 REV: J
CUSTOMER ACCESSIBLE PRODUCTION DRAWING		SHEETS 3 & 4 ARE NOT REQUIRED FOR ATLANTIC VERSION	

PART NUMBER	REVISION	DESCRIPTION	FEED TYPE
2-2150150-1	H	FINE CRIMP HEIGHT ADJUST	MECHANICAL
2-2150150-2	J	FINE CRIMP HEIGHT ADJUST	PNEUMATIC
7-2150150-7	A	CRIMP TOOLING KIT	-

PACIFIC VERSION TERMINATOR
INTERFACE ADAPTER

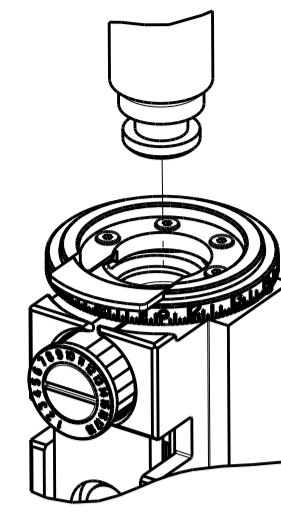

APPLICATOR DATA		
CRIMP	SIZE	TYPE
WIRE	1.57 mm [.062]	○
NOSE	1.57 mm [.062]	○
APPLICATOR INSTRUCTIONS 408-35043		

TERMINAL DATA: TE TERMINAL		TE CRIMP SPECIFICATION	
TERMINAL NAME: CIRCULAR WIRE PIN			
WIRE STRIP LENGTH 7.54-8.33 mm [.297-.328 IN]		INSULATION DIAMETER RANGE -	
TERMINAL APPLICATION SPECIFICATION	NONE	-	-
TERMINALS APPLIED			
TE TERMINAL	TE TERMINAL	TE TERMINAL	TE TERMINAL
926933-1	926933-3	926933-6	926933-8
926933-2	926933-4	926933-7	926933-9



WIRE SIZE	WIRE CRIMP HEIGHT mm [INCH]	WIRE CRIMP HEIGHT REFERENCE SETTING	NOSE CRIMP HEIGHT	NOSE CRIMP HEIGHT REFERENCE SETTING
1.00mm2	1.55+/-0.05 [.061+/-0.002]	8	1.76+/-0.05 [.069+/-0.002]	5.1
0.75mm2	1.45+/-0.05 [.057+/-0.002]	7	1.65+/-0.05 [.065+/-0.002]	6.2
0.50mm2	1.14+/-0.05 [.045+/-0.002]	12	1.55+/-0.05 [.061+/-0.002]	7.6

- 1 RECOMMENDED SPARE PARTS
- 2 REFER TO SUPPLIED INSTRUCTION SHEET FOR CLEANING, LUBRICATION AND STORAGE OF APPLICATOR.
- 3 APPLY PART NUMBER 2-23419-6 LOCTITE TO THREADS OF ITEM 242.
- 4 CRIMP HEIGHT REFERENCE SETTING WAS THE SETTING USED WHEN THE APPLICATOR WAS QUALIFIED AT THE FACTORY. ADJUSTMENT MAY BE NECESSARY WHEN RUNNING APPLICATOR IN THE FIELD.
- 5 TERMINAL LUBRICANT IS RECOMMENDED.
- 6 UNLESS SPECIFIED OTHERWISE TORQUE VALUES SHALL BE USED PER DOCUMENT, 101-35000.
- 7 CRIMP HEIGHTS FOR WIRE BARRELS ONLY. ADJUST ITEM 244 TO OBTAIN WIRE CRIMP HEIGHT.
- 8 WIRE SIZE APPLIES ONLY FOR HANDBRAKE CONTACT REFER TO BMW DRAWING 6 928 203.
- 9 ITEM 244 ADJUSTS WIRE CRIMP HEIGHT. THE WIRE CRIMP HEIGHT ADJUST DIAL ADJUSTS INSULATION (NOSE) CRIMP HEIGHT.
- 10 POSITION ITEM 27 IN FRONT OF ITEM 77.

***WARNING**
ON INSTALLATION, SET WIRE DISC TO CRIMP HEIGHT REFERENCE SETTING FOR LARGEST WIRE SIZE. CRIMP HEIGHT REFERENCE SETTINGS GREATER THAN THE VALUE SHOWN MAY CAUSE DAMAGE TO THE CRIMP TOOLING. REFER TO THE INSTRUCTION SHEET FOR PROPER SETUP AND ADJUSTMENTS.

PACIFIC VERSION
Shown on sheets 3 of 4 & 4 of 4
(Atlantic version shown on sheets 1 of 4 & 2 of 4)

LOC	DIST	REV	DATE	BY	APPD
A	66	-	-	-	-

REV	DATE	DESCRIPTION	BY	APPD	
-	1	1	2119082-2	CAM, SNAIL, INSULATION ADJUSTMENT	244
-	1	1	2079764-1	WASHER, WAVE SPRING, CREST-TO-CREST	243
-	1	1	2119083-1	RETAINER, INSULATION DIAL	242
-	-	1	2119580-1	MECHANICAL FEED ASSEMBLY	239
-	1	-	2844940-3	AIR FEED MODULE	238
-	1	1	1803071-1	SPACER, REAR SHEAR STRIP GUIDE	196
-	1	1	3-459722-7	BLADE, SHEAR	195
-	4	4	2079383-9	SCR, BHSC, RoHS (M6 X 20)	186
-	REF	REF	994970-2	COUNTER, MAGNETIC	164
-	1	-	2119641-2	FEED CAM, AIR FEED	152
-	-	1	2119653-2	FEED CAM, POST FEED	142
-	1	1	3-2119655-2	APPLICATOR BASIC ASSEMBLY, EF	141
-	1	1	1803518-1	RAM ASSEMBLY, EF PACIFIC	140
-	1	1	2119955-2	ASSY, LUBRICATOR, END FEED	84
-	1	1	455888-4	SPACER, CRIMPER	82
-	1	1	1803203-2	BLOCK, FRONT DEPRESSOR	77
-	1	1	2119791-9	DEPRESSOR, WIRE	73
-	1	1	1803607-4	DOCUMENTATION PACKAGE	71
-	2	2	2-18032-2	SCR, SET, FLT PNT, M3 X 10.0	70
-	1	1	2119740-1	TAG, IDENTIFICATION	67
-	2	2	2168078-1	SCREW, DRIVE, RH, RoHS, 2 x .188	66
-	2	2	2168400-8	SHCS, LOW HEAD, RoHS, M4 X 16	64
-	1	1	5-18022-5	SCR, HEX HD CAP, M4 X 6.0	59
-	-	1	2063961-1	FEED FINGER	58
-	3	3	2168400-4	SHCS, LOW HEAD, RoHS, M4 X 8	57
-	2	2	5018030-1	NUT, HEX, REG, RoHS, M3	54
-	2	2	986965-8	NUT, LOCK, HEX, TORQUE (M4)	53
-	1	-	2063961-9	FEED FINGER	51
-	1	2	18023-9	SCR, SKT HD CAP M4 X 6.0	49
-	-	1	2119652-1	FEED CAM, PRE FEED	48
-	1	1	1803602-1	SCR, BHSC, RoHS (M8 X 25)	41
-	7	7	1-18028-2	WASHER, FLAT, REG M4	33
-	2	2	1-2168083-2	SCR, SKT HD CAP, RoHS, M4 X 25	31
-	2	2	2168083-2	SCR, SKT HD CAP, RoHS, M4 X 8.0	29
-	1	1	690455-1	STRIPPER, FRONT CASTING	27
-	2	2	1-2168083-5	SCR, SKT HD CAP, RoHS, M4 X 30	25
-	1	1	1752371-5	PLATE, STRIP GUIDE	24
-	1	1	240825-1	PLATE, STRIP HOLD DOWN	23
-	2	2	2-22281-3	SPRING, COMPRESSION	22
-	1	1	1803292-4	DRAG	20
-	2	2	1901259-4	GUIDE, LOWER STRIP	18
-	1	1	2-240644-5	PLATE, REAR SHEAR	11
-	2	2	6-240645-5	SPACER, SHEAR PLATE	10
-	1	1	1633342-5	ANVIL, WIRE	8
-	1	1	238011-3	BLOCK, CRIMPER SPACER	4
-	1	1	5-2119784-6	CRIMPER, INSULATION O PREMIUM	3
-	1	1	6-459492-8	CRIMPER, WIRE O	1
-	77-22-21		PART NO	DESCRIPTION	ITEM NO

DIMENSIONS: mm		TOLERANCES UNLESS OTHERWISE SPECIFIED:		DWG: HOFFNER 12JUN2012		CHK: T. ELBIN 13JUN2012		APPD: T. ELBIN 13JUN2012		NAME: TE Connectivity Harrisburg, PA 17105-3608	
0 PLC	±	1 PLC	±	2 PLC	±	3 PLC	±	4 PLC	±	5 PLC	±
MATERIAL: -		FINISH: -		WEIGHT: -		SCALE: 1:1		SHEET: 3 OF 4		REV: J	

LOC		DIST		REVISIONS			
A	66	P	LTM	DESCRIPTION	DATE	OWN	APVD
		-	-	SEE SHEET 1	-	-	-

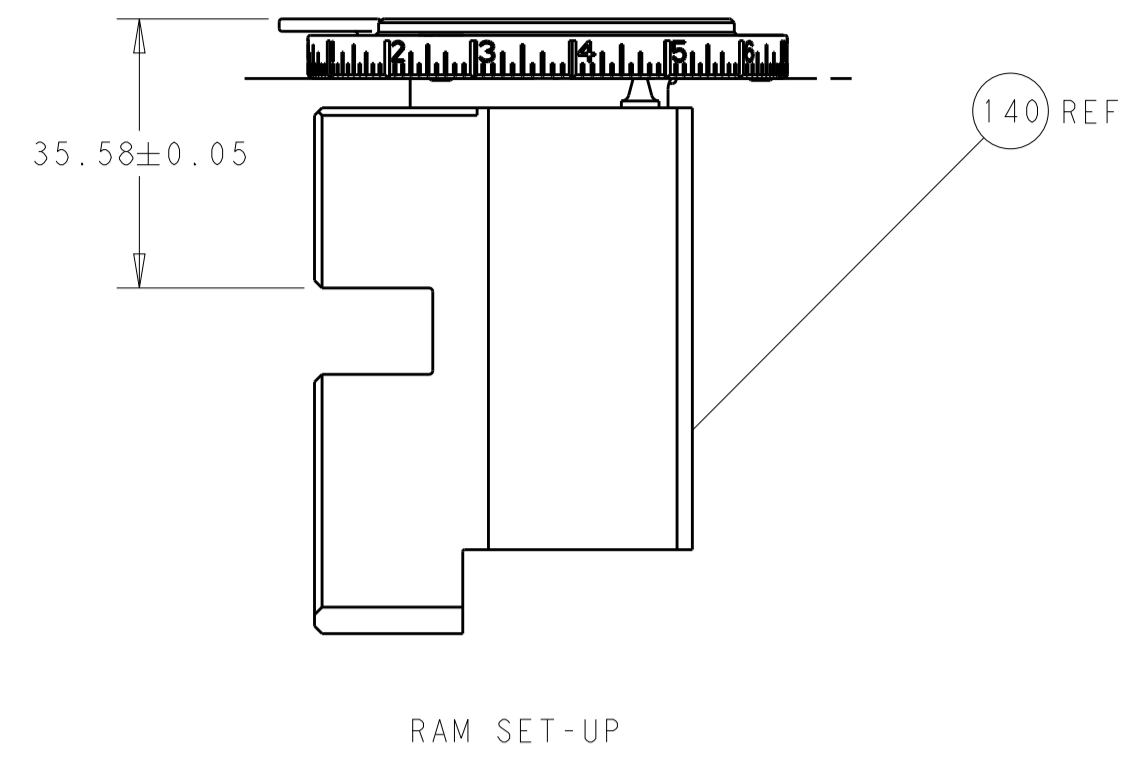

FEED TYPE
 MECHANICAL

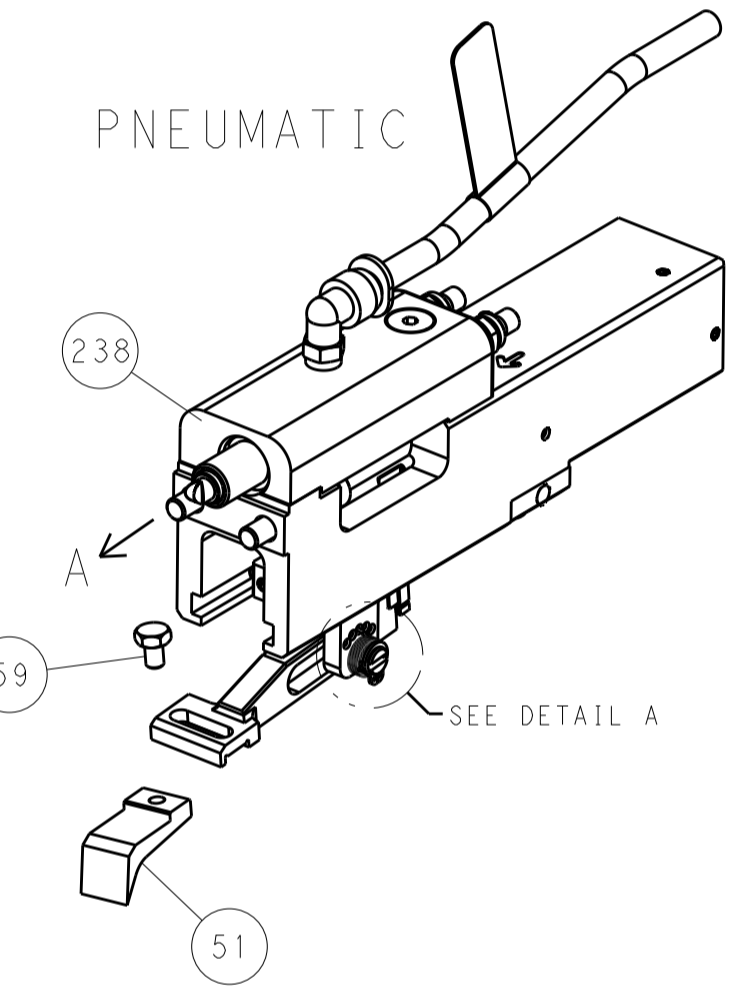
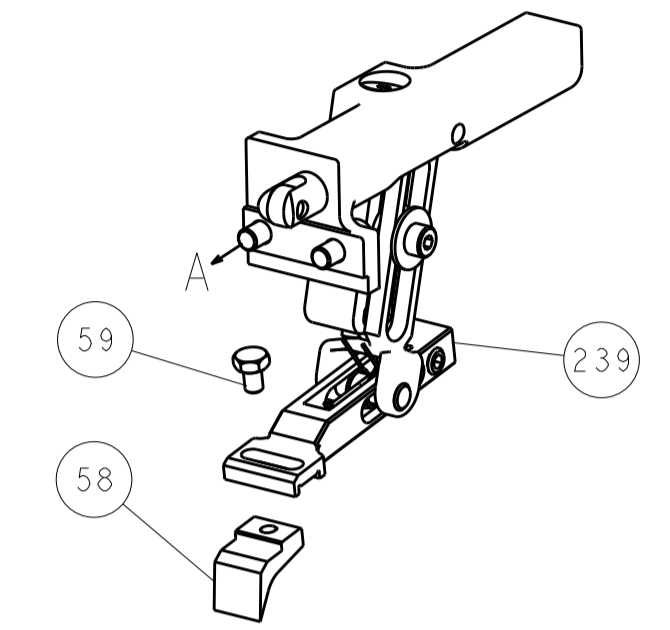

FEED SPRING
 SETTING POSITION

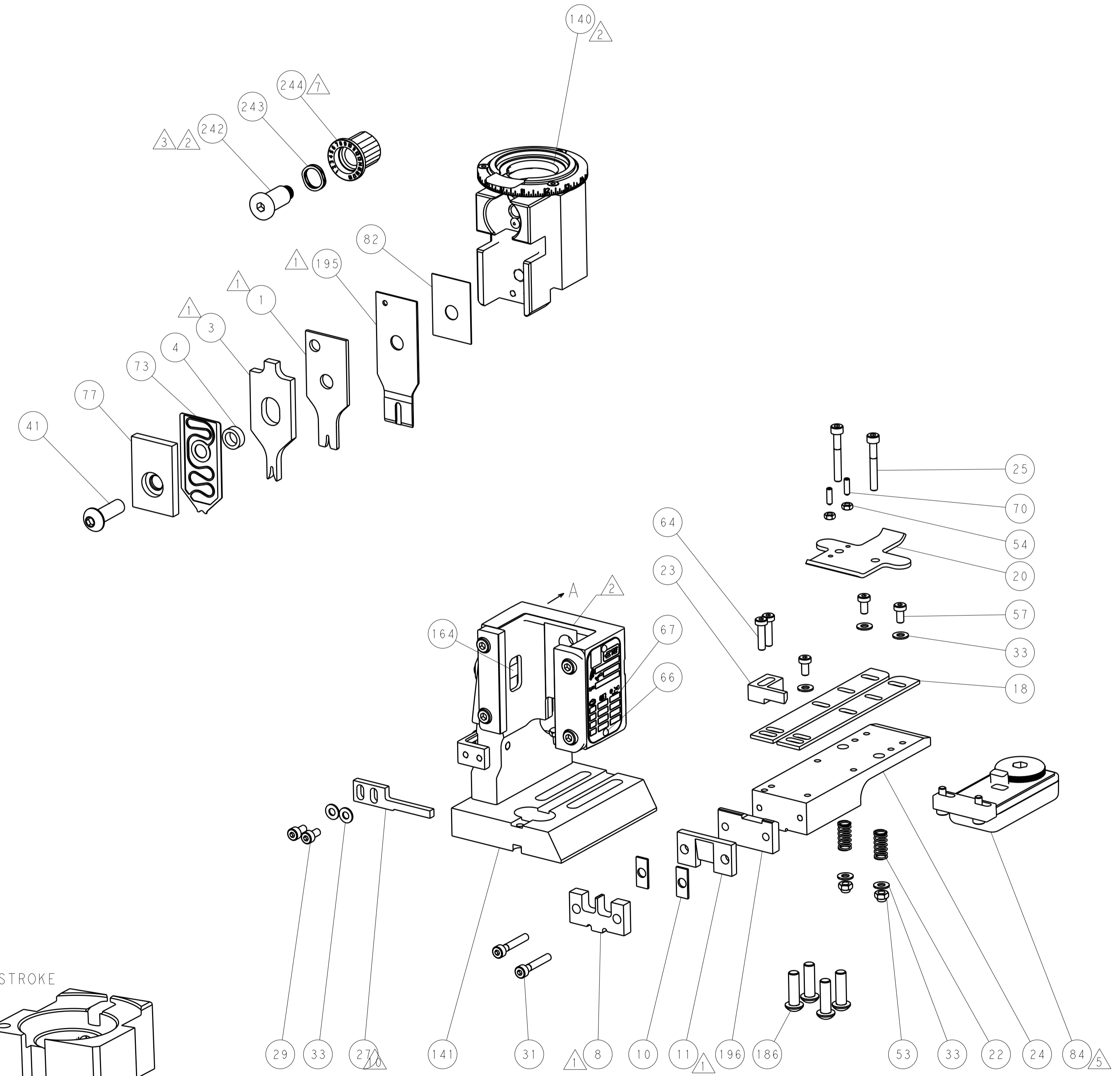
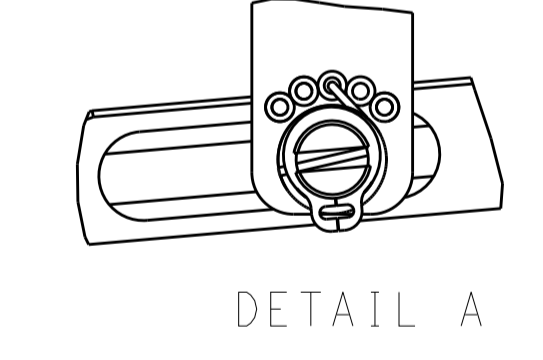

CAM POSITIONS

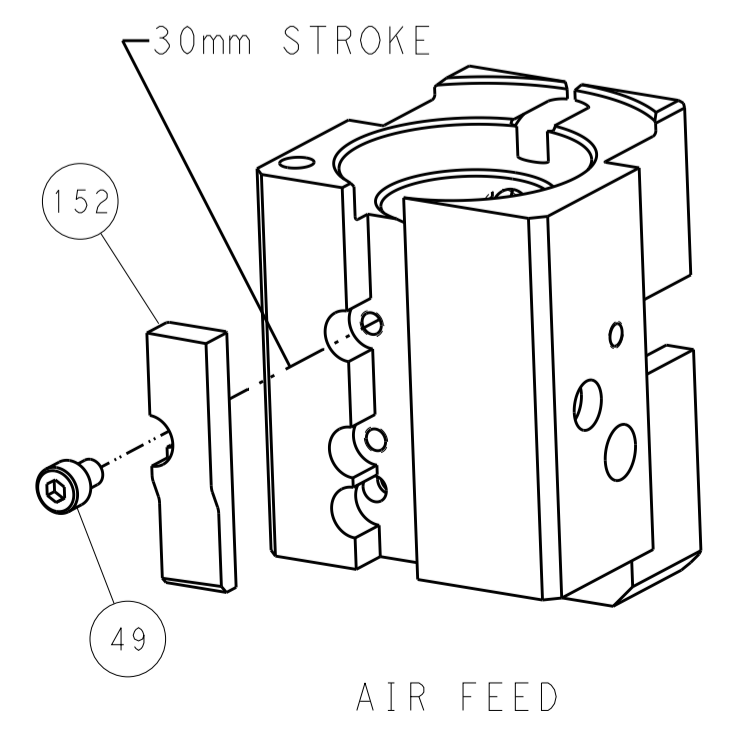
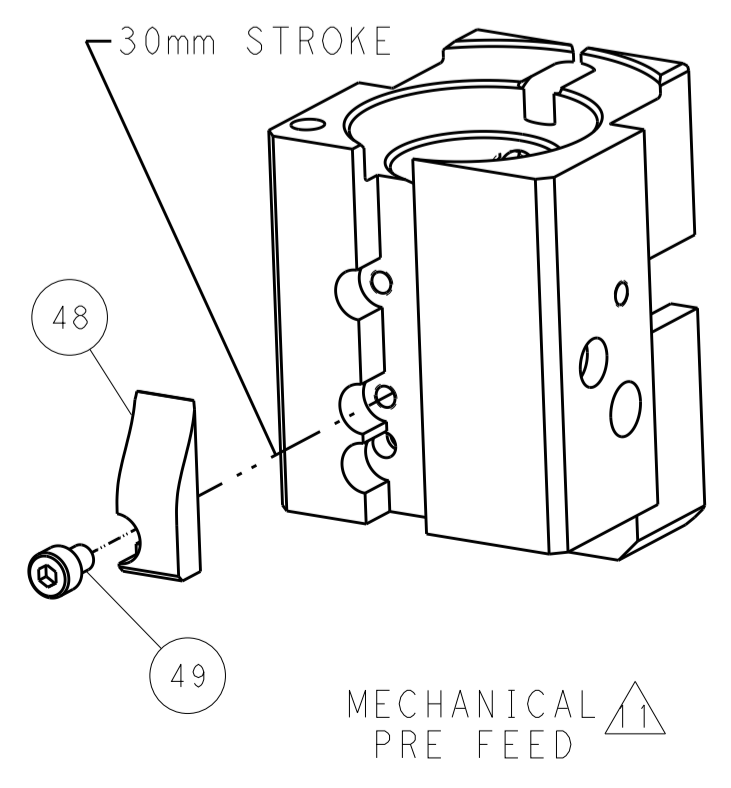
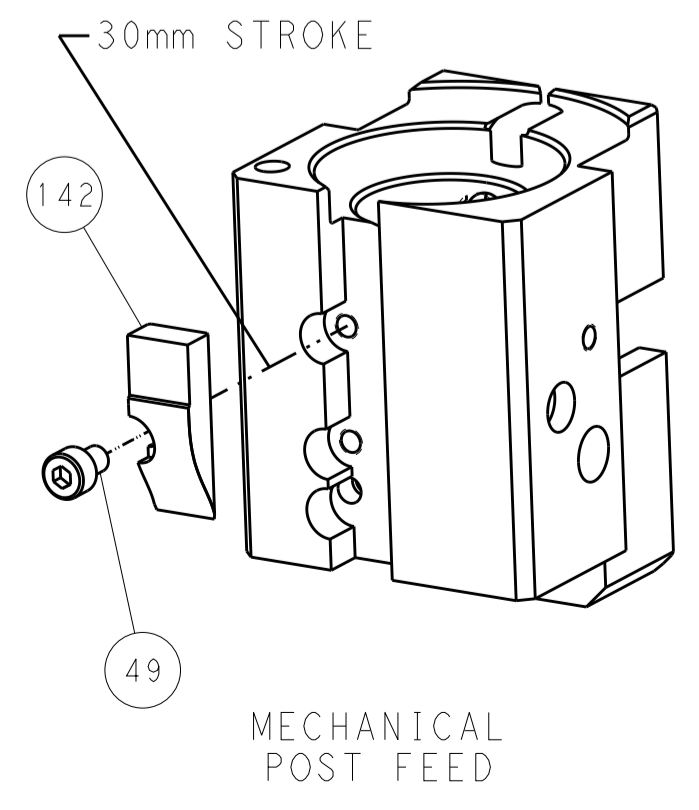

PACIFIC VERSION
 Shown on sheets 3 of 4 & 4 of 4
 (Atlantic version shown on sheets 1 of 4 & 2 of 4)

DIMENSIONS:		TOLERANCES UNLESS OTHERWISE SPECIFIED:		DWN: HOFFNER 12JUN2012		STE TE Connectivity	
mm	0 PLC ±	1 PLC ±	2 PLC ±	3 PLC ±	4 PLC ±	5 PLC ±	Harrisburg, PA 17105-3608
MATERIAL:	FINISH:	WEIGHT:	SCALE:	SIZE:	CAGE CODE:	DRAWING NO:	RESTRICTED TO:
			1:1	A11	00779	2150150	
Customer Accessible Production Drawing				SHEET 4 OF 4 REV J			