

# Reflective Object Sensors

## Types OPB703W, OPB704W, OPB705W

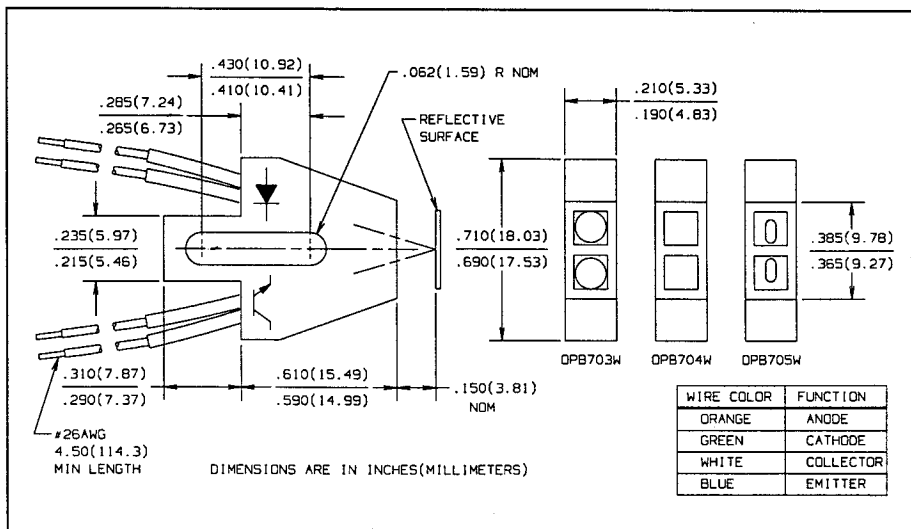
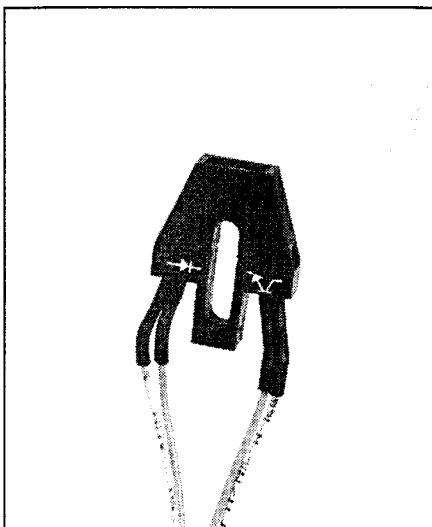

### Features

- Phototransistor output
- High sensitivity
- Low cost plastic housing
- Available with lenses for dust protection and ambient light filtration

### Description

The OPB703W, OPB704W and OPB705W each consist of an infrared emitting diode and an NPN silicon phototransistor mounted side-by-side on converging optical axes in a black plastic housing. The phototransistor responds to radiation from the emitter only when a reflective object passes within its field of view. Various options allow no lens, blue polysulfone lens for dust protection or offset lens for improved resolution.

Leads are 26 AWG, PVC insulation, 4.5" (114.3mm) minimum length, stripped & tinned.

### Absolute Maximum Ratings (T<sub>A</sub> = 25° C unless otherwise noted)

Storage and Operating Temperature . . . . . -40° C to +80° C  
 Lead Soldering Temperature [1/16 inch (1.6 mm) from case for 5 sec. with soldering iron]. . . . . 240° C<sup>(1)</sup>

### Input Diode

Forward DC Current . . . . . 40 mA  
 Reverse DC Voltage . . . . . 2.0 V  
 Power Dissipation . . . . . 100 mW<sup>(2)</sup>

### Output Phototransistor

Collector-Emitter Voltage . . . . . 30 V  
 Emitter-Collector Voltage . . . . . 5.0 V  
 Collector DC Current . . . . . 25 mA  
 Power Dissipation . . . . . 100 mW<sup>(2)</sup>

### Notes:

- (1) RMA flux is recommended. Duration can be extended to 10 sec. max when flow soldering.
- (2) Derate linearly 1.82 mW/° C above 25° C.
- (3) d is the distance from the assembly face to the reflective surface.
- (4) Lower curve is based on a calculated worst case condition rather than the conventional -2σ limit.
- (5) All parameters tested using pulse technique.
- (6) Crosstalk is the photocurrent measured with current to the input diode and no reflecting surface.
- (7) Measured using Eastman Kodak neutral white test card with 90% diffuse reflectance as a reflecting surface. Reference: Eastman Kodak, Catalog #1257795.

### DESCRIPTION

OPB703W	No Lens
OPB704W	Blue Polysulfone Lens
OPB705W	Offset Lens



For RoHS compliant devices add "Z" to the end of the part number: OPB703WZ

# Types OPB703W, OPB704W, OPB705W

Electrical Characteristics ( $T_A = 25^\circ\text{C}$  unless otherwise noted)

REFLECTIVE OBJECT SENSORS

SYMBOL	PARAMETER	MIN	MAX	UNITS	TEST CONDITIONS
<b>Input Diode</b>					
$V_F$	Forward Voltage		1.70	V	$I_F = 40\text{ mA}$
$I_R$	Reverse Current		100	$\mu\text{A}$	$V_R = 2.0\text{ V}$
<b>Output Phototransistor</b>					
$V_{(BR)CEO}$	Collector-Emitter Breakdown Voltage	30		V	$I_{CE} = 100\ \mu\text{A}$
$V_{(BR)ECO}$	Emitter-Collector Breakdown Voltage	5.0		V	$I_{EC} = 100\ \mu\text{A}$
$I_{CEO}$	Collector Dark Current		100	nA	$V_{CE} = 10\text{ V}, I_F = 0, E_e = 0$
<b>Combined</b>					
$I_{C(ON)}$	On-State Collector Current	OPB703W OPB704W OPB705W	200 200 100	$\mu\text{A}$ $\mu\text{A}$ $\mu\text{A}$	$V_{CE} = 5\text{ V}, I_F = 40\text{ mA}, d = 0.15\text{ in. (3.81 mm)}^{(3)(7)}$
$I_{CX}$	Crosstalk	OPB703W OPB704W OPB705W	20 20 10	$\mu\text{A}$ $\mu\text{A}$ $\mu\text{A}$	$V_{CE} = 5\text{ V}, I_F = 40\text{ mA}^{(6)}$

## Typical Performance Curves

Reflective Surface Collector Current vs. Diode Forward Current

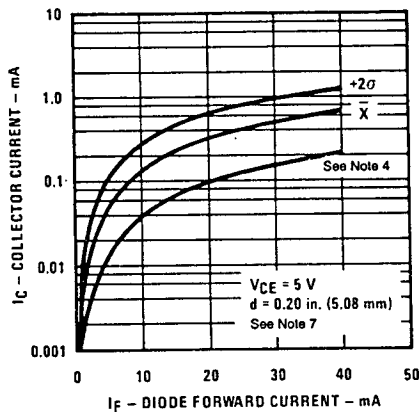

Diffused Surface Collector Current vs. Diode Forward Current

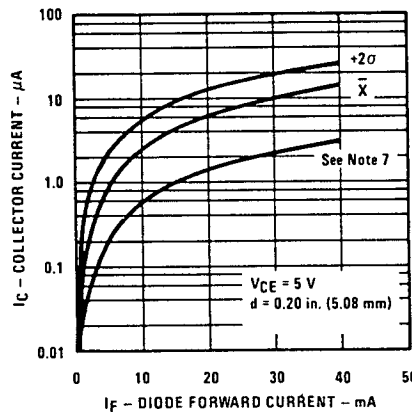

Normalized Collector Current vs. Ambient Temperature

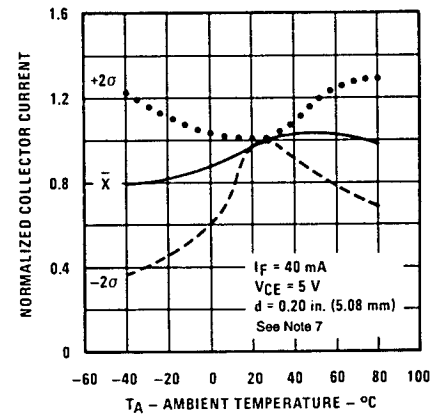

Normalized Collector Current vs. Object Distance

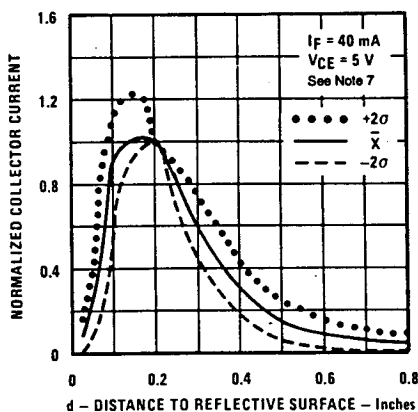

Rise and Fall Time vs. Load Resistance

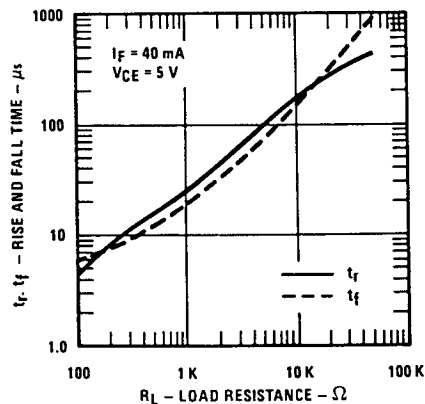

Test Condition

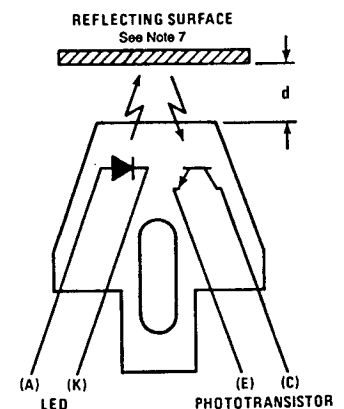

Optek reserves the right to make changes at any time in order to improve design and to supply the best product possible.

Optek Technology, Inc. 1215 W. Crosby Road Carrollton, Texas 75006 (972)323-2200 Fax (972)323-2396