

Double Pole, Electrically Held, 5 Amps and Less (Continued)

FW, FW5A, SF, SF5A
Two Pole Full Size
Crystal-Can Relay
FW Qualified to
MIL-R-5757/10

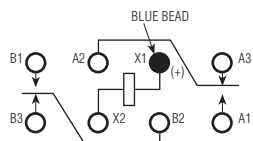

Terminal View

Product Facts

- Hermetically sealed
- Up to 5 amps switching
- High shock & vibration ratings
- Optional terminals & mounting options
- Excellent RF switching

Electrical Characteristics

Contact Arrangement — 2 Form C
Contact Material — Stationary — Bifurcated hardened silver alloy
 Moveable — Gold plated hardened alloy
Contact Resistance — Before Life — 50 milliohms max. (measured at 10 mA @ 6 Vdc)
 After Life — 100 milliohms max. (measured @ 2 mA @ 28 Vdc)
Mechanical Life Expectancy — 50 million operations
Coil Voltage — 6.3 to 110 Vdc (FW, FW5A)
 1.8 to 40 Vdc (SF)
 2.8 to 40 Vdc (SF5A)
Coil Power — 1.5 watts max. @ 25°C
Duty Cycle — Continuous
Pick-up Voltage — Approximately 50% of nominal coil voltage
Pick-up Sensitivity — 250 mW (FW, FW5A)
 40 mW (SF)
 80 mW (SF5A)

Operating Characteristics

Operate Time — 15 ms max. (SF)
 5 ms (FW, FW5A)
 6 ms max. (MIL-R-5757/10)
Release Time — 10 ms max. (SF)
 5 ms max. (FW, FW5A)
 6 ms max. (MIL-R-5757/10)
Contact Bounce — 2 ms max.
Dielectric Withstanding Voltage — Between Open Contacts — 500 Vrms 60 Hz
 Between Adjacent Contacts — 1,000 Vrms 60 Hz
 Between Contacts and Coil — 1,000 Vrms 60 Hz
Insulation Resistance — 10,000 megohms min @ 500 Vdc

Environmental Characteristics

Temperature Range — -65°C to +125°C
Weight — 0.6 oz. max. (FW, FW5A)
 0.7 oz. max. (SF 6)
 1.1 oz. max. (SF/SF 5A)
Vibration Resistance — Standard — 20 G's, 10 to 2000 Hz (FW, FW5A)
 15 G's, 10 to 2000 Hz (SF)
 QPL — 20 G's, 10 to 2000 Hz
Shock Resistance — 100 G's, 6 ±1 ms
QPL Approval — MIL-R-5757/10 (FW only)
QPL Equivalent — MIL-R-5757/13 (SF only)

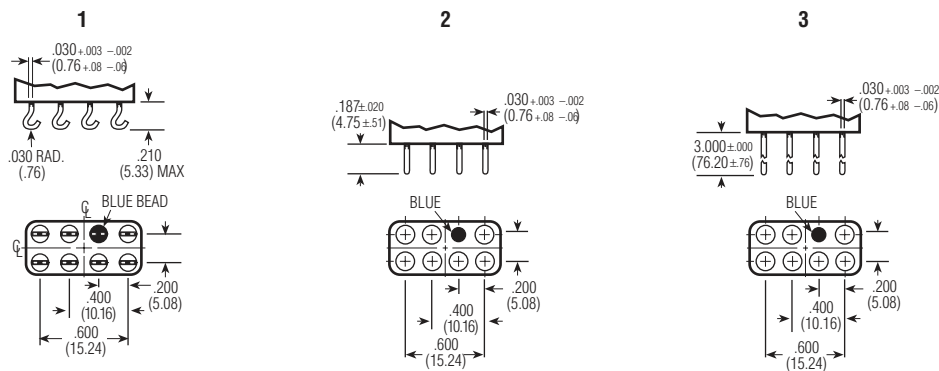

Terminals

RF Performance

Frequency (MHz)	RF Losses (dB)	VSWR	Isolation (dB)
100	0.1	1.17:1	40
250	0.2	1.18:1	33
500	0.3	1.19:1	28
750	0.4	1.19:1	25
1,000	0.4	1.19:1	23

Contact Ratings

Contact Load	Type	Operations Min.
5 A @ 28 Vdc (FW5A/SF5A)	Resistive	100,000
3 A @ 28 Vdc (FW)	Resistive	100,000
2 A @ 28 Vdc (SF)	Resistive	100,000
1 A @ 115 Vac, 60 Hz & 400 Hz (FW)	Resistive	100,000
0.3 A @ 115 Vac, 60 Hz & 400 Hz (SF)	Resistive	100,000
1 A @ 28 Vdc	Inductive (200 mH)	100,000
0.1 A @ 28 Vdc	Lamp	100,000
10 µA @ 50 mVdc	Low Level	1,000,000
75 WATTS @ 50 MHz (FW)	RF	10,000,000

Double Pole, Electrically Held, 5 Amps and Less (Continued)

FW, FWSA Coil Data

Nom. Coil Voltage (Vdc)	Coil Resistance in Ohms ±10% @ 25°C	Pickup Voltage Vdc (Max.) @ 25°C	Pickup Voltage Vdc (Max.) @ 125°C	Drop-out Voltage Vdc (Min.) @ 25°C	Drop-out Voltage Vdc (Min.) @ -65°C	Nom. Coil Power (W) @ 25°C	Max. Coil Voltage	Coil Desig.
6.3	35	3.2	4.4	0.35	0.23	1.13	7.9	A
12.6	200	6.8	9.4	0.74	0.49	.79	15.8	D
17.6	340	8.9	12.3	0.97	0.64	.91	22.0	E
26.5	675	13.5	18.7	1.47	0.96	1.04	33.1	G
32.0	975	15.5	21.5	1.69	1.1	1.05	40.0	H
48.0	2,450	25.0	34.7	2.73	1.8	.94	60.0	L
56.0	3,150	30.0	41.6	3.27	2.1	1.90	70.0	M
75.0	5,000	38.0	52.7	4.14	2.7	1.13	93.8	N
110.0	9,100	51.0	70.7	5.56	3.6	1.33	137.5	R

SF5/SF6 Coil Data

Nom. Coil Voltage (Vdc)	Nom. Current (mA)	Coil Resistance in Ohms ± 10% @ 25°C	Pickup Current (mA) @ 25°C	Nom. Coil Power (mW) @ 25°C	Coil Desig.
1.8	90.0	20	45.0	162	A
9.0	18.0	500	9.0	162	E
12.6	12.6	1,000	6.5	159	F
16.5	11.0	1,500	5.2	182	G
18.0	9.0	2,000	4.5	162	H
20.0	8.0	2,500	4.0	160	J
26.5	5.3	5,000	2.8	140	W
36.0	4.5	8,000	2.3	162	L
40.0	4.0	10,000	2.0	160	Y

SF5A Coil Data

Nom. Coil Voltage (Vdc)	Nom. Current (mA)	Coil Resistance in Ohms ± 10% @ 25°C	Pickup Current (mA) @ 25°C	Nom. Coil Power (mW) @ 25°C	Coil Desig.
2.8	140.0	20	65.0	392	A
4.0	80.0	50	41.6	320	B
12.0	24.0	500	12.5	288	E
18.0	18.0	1,000	9.3	324	F
26.5	10.6	2,500	5.6	281	J
40.0	8.0	5,000	4.0	320	W

NOTE:
FW/FW5A = .875 (22.23) Max.
SF6 = .900 (22.86) Max.
SF5/SF5A5 = 1.281 (32.54) Max.

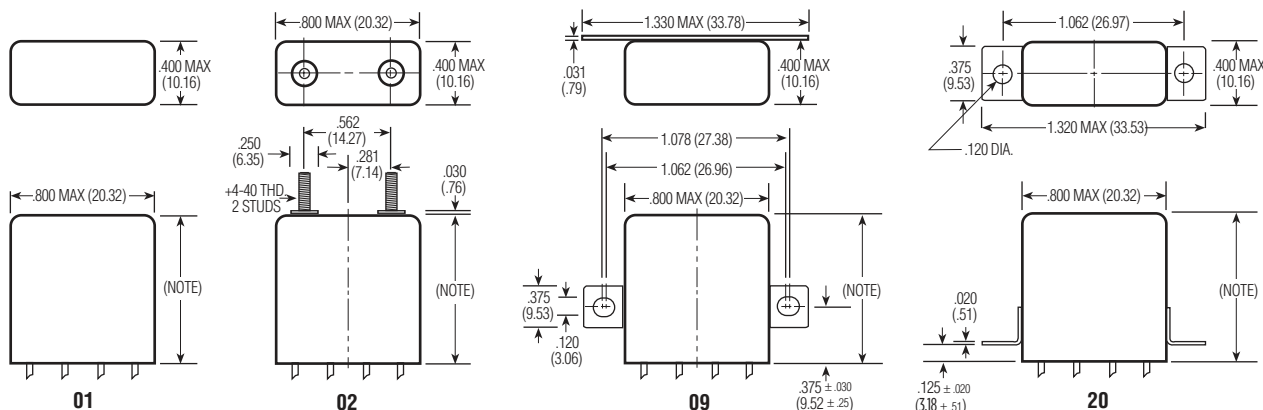

Mounting Styles

Specifying a Part Number Example:

Type	Series	Terminals	Mountings	Coils	Features
FW	1	1	20	G	00
SF	5	1	20	W	00
SF5A	5	1	20	W	00
SF	6	1	20	W	00