

XC74WL240ASR



CMOS Logic

- ◆ CMOS Logic Dual Bus Buffer
(Inverted 3-state outputs)
- ◆ Operating Voltage Range : 2V ~ 5.5V
- ◆ High Speed Operations : $t_{pd} = 3.8\text{ns}$ (TYP.)
- ◆ Low Power Consumption : $2\mu\text{A}$ (MAX.)
- ◆ MSOP-8B Package

■ GENERAL DESCRIPTION

XC74WL240ASR is dual bus buffer manufactured using silicon gate CMOS processes. The small supply current, which is one of the features of the CMOS logic, gives way to high speed operations which enables LS-TTL.

With wave forming buffers connected internally, stabilized output can be achieved as the series offers high noise immunity.

As the series is integrated into a mini molded, MSOP-8B package, high density mounting is possible.

■ APPLICATIONS

- Palmtops
- Digital equipment

■ FEATURES

High Speed Operations : $t_{pd} = 3.8\text{ns}$ (TYP.) ($V_{CC}=5\text{V}$)

Operating Voltage Range : 2V ~ 5.5V

Low Power Consumption: $2\mu\text{A}$ (MAX.)

Small Package : MSOP-8B

■ PIN CONFIGURATION

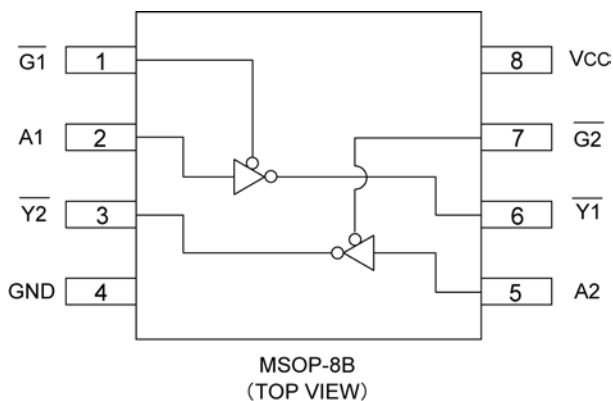

■ FUNCTIONS

INPUT		OUTPUT
\overline{G}	A	\overline{Y}
H	X	Z
L	H	L
L	L	H

H=High level

L=Low level

X=Don't care

Z=High impedance

■ ABSOLUTE MAXIMUM RATINGS

$T_a = -40^\circ\text{C} \sim 85^\circ\text{C}$

PARAMETER	SYMBOL	RATINGS	UNITS
Supply Voltage	V_{CC}	-0.5~+6.0	V
Input Voltage	V_{IN}	-0.5~+6.0	V
Output Voltage	V_{OUT}	-0.5~ $V_{CC}+0.5$	V
Input Diode Current	I_{IK}	-20	mA
Output Diode Current	I_{OK}	± 20	mA
Switch Output Current	I_{OUT}	± 25	mA
V_{CC}, GND Current	I_{CC}, I_{GND}	± 50	mA
Power Dissipation ($T_a = 25^\circ\text{C}$)	P_d	300	mW
Storage Temperature Range	T_{stg}	-65~+150	$^\circ\text{C}$

Note : Voltage is all ground standardized.

XC74WL240ASR

RECOMMENDED OPERATING CONDITIONS

PARAMETER	SYMBOL	CONDITIONS	UNITS
Supply Voltage	V _{CC}	2~5.5	V
Input Voltage	V _{IN}	0~5.5	V
Output Voltage	V _{OUT}	0~V _{CC}	V
Operating Temperature Range	T _{opr}	-40~+85	°C
Input Rise and Fall Time	t _{r,tf}	0~200 (V _{CC} =3.3V)	ns
		0~100 (V _{CC} =5V)	

DC ELECTRICAL CHARACTERISTICS

PARAMETER	SYMBOL	V _{CC} (V)	CONDITIONS	T _a =25°C			T _a =-40°C~85°C		UNITS	
				MIN.	TYP.	MAX.	MIN.	MAX.		
Input Voltage	V _{IH}	2.0		1.50	-	-	1.50	-	V	
		3.0		2.10	-	-	2.10	-		
		5.5		3.85	-	-	3.85	-		
	V _{IL}	2.0		-	-	0.50	-	0.50	V	
		3.0		-	-	0.90	-	0.90		
		5.5		-	-	1.65	-	1.65		
Output Voltage	V _{OH}	2.0	V _{IN} =V _{IL}	I _{OH} =-50μ A	1.90	2.00	-	1.90	-	V
		3.0			2.90	3.00	-	2.90	-	
		4.5			4.40	4.50	-	4.40	-	
		3.0		I _{OH} =-4mA	2.58	-	-	2.48	-	
		4.5			I _{OH} =-8mA	3.94	-	-	3.80	
	V _{OL}	2.0	V _{IN} =V _{IH}	I _{OL} =50μ A	-	-	0.10	-	0.10	V
		3.0			-	-	0.10	-	0.10	
		4.5			-	-	0.10	-	0.10	
		3.0		I _{OL} =4mA	-	-	0.36	-	0.44	
		4.5			I _{OL} =8mA	-	-	0.36	-	
3 State Off-Leak Current	I _{oz}	5.0	V _{IN} =V _{IL} or V _{IH} , V _{OUT} =V _{CC} or GND	-0.25	-	0.25	-2.50	2.50	μ A	
Input Current	I _{IN}	0~5.5	V _{IN} =V _{CC} or GND	-0.10	-	0.1	-1.00	1.00	μ A	
Static Supply Current	I _{CC}	5.5	V _{IN} =V _{CC} or GND	-	-	2.0	-	20.0	μ A	

■ SWITCHING ELECTRICAL CHARACTERISTICS

(tr=tf=3ns)

PARAMETER	SYMBOL	CONDITIONS		Ta=25°C			Ta=-40°C~85°C		UNITS		
		CL	Vcc(V)	MIN.	TYP.	MAX.	MIN.	MAX.			
Delay Time	tPLH	15pF	3.3		-	5.6	8.0	1.0	9.5	ns	
			5.0		-	3.8	5.5	1.0	6.5		
		50pF	3.3		-	8.1	11.5	1.0	13.0	ns	
			5.0		-	5.3	7.5	1.0	8.5		
	tPHL	15pF	3.3		-	5.6	8.0	1.0	9.5	ns	
			5.0		-	3.8	5.5	1.0	6.5		
		50pF	3.3		-	8.1	11.5	1.0	13.0	ns	
			5.0		-	5.3	7.5	1.0	8.5		
Output Enable Time	tZL	15pF	3.3	RL=1kΩ	-	5.4	8.0	1.0	9.5	ns	
			5.0		-	3.6	5.1	1.0	6.0		
		50pF	3.3			-	7.9	11.5	1.0	13.0	ns
			5.0			-	5.1	7.1	1.0	8.0	
	tZH	15pF	3.3	RL=1kΩ	-	5.4	8.0	1.0	9.5	ns	
			5.0		-	3.6	5.1	1.0	6.0		
		50pF	3.3			-	7.9	11.5	1.0	13.0	ns
			5.0			-	5.1	7.1	1.0	8.0	
Output Disable Time	tLZ	50pF	3.3	RL=1kΩ	-	9.5	13.2	1.0	15.0	ns	
			5.0		-	6.1	8.8	1.0	10.0		
	tHZ	50pF	3.3	RL=1kΩ	-	9.5	13.2	1.0	15.0	ns	
			5.0		-	6.1	8.8	1.0	10.0		
Output Pin Skew (Note)	tosLH	50pF	3.3		-	-	1.5	-	1.5	ns	
			5.0		-	-	1.0	-	1.0		
	tosHL	50pF	3.3		-	-	1.5	-	1.5	ns	
			5.0		-	-	1.0	-	1.0		
Input Capacitance	CIN	-	-		-	4	10	-	10	pF	
Output Capacitance	COUT	-	-		-	6	-	-	-	pF	
Power Dissipation Capacitance	Cpd	-	-		-	17	-	-	-	pF	

Note: tosLH and tosHL are the guaranteed parameters.

$$\text{tosLH} = |t_{\text{PLHm}} - t_{\text{PHLn}}|, \text{tosHL} = |t_{\text{PHLm}} - t_{\text{PLLn}}|$$

■ NOISE CHARACTERISTICS

(tr=tf=3ns)

PARAMETER	SYMBOL	CONDITIONS		Ta=25°C			UNITS	
		CL	Vcc(V)	MIN.	TYP.	MAX.		
Non Functional Output Maximum Dynamic VOL	VOLP	50pF	5.0		-	0.3	0.8	V
Non Functional Output Minimum Dynamic VOL	VOLV	50pF	5.0		-0.8	-0.3	-	V
Minimum Dnamic VIH	VIHD	50pF	5.0		-	-	3.5	V
Maximum Dnamic VIL	VILD	50pF	5.0		-	-	1.5	V

XC74WL240ASR

■ DELAY TIME

- Test Circuit

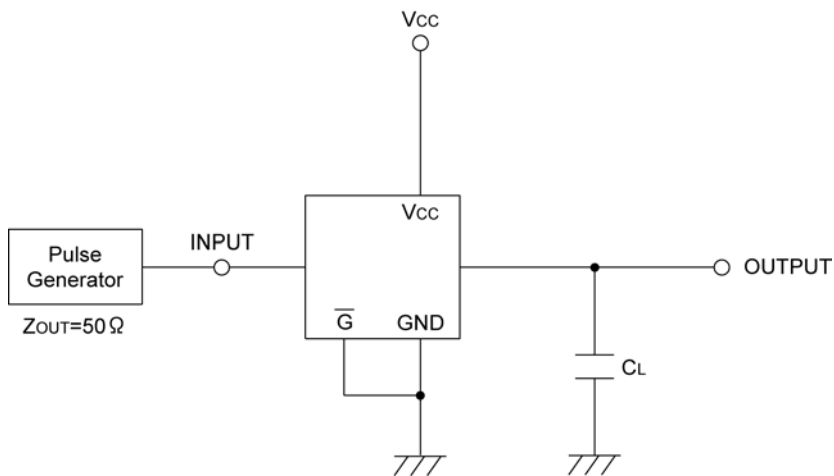

- Waveform

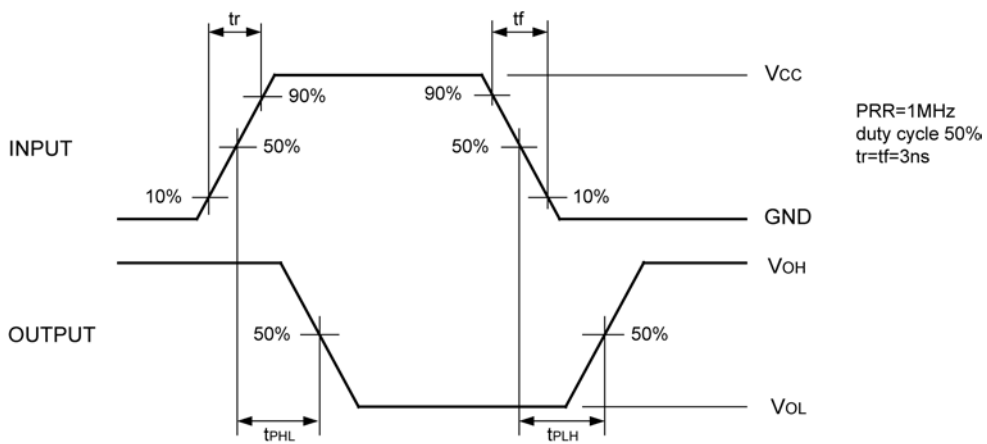

■ OUTPUT ENABLE TIME, OUTPUT DISABLE TIME

• Test Circuit

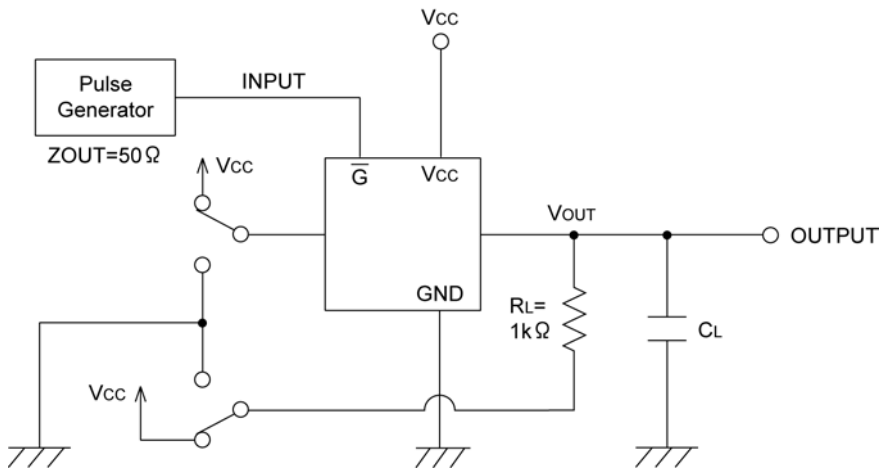

• Waveform

