

THIS DRAWING IS UNPUBLISHED. RELEASED FOR PUBLICATION 2004
 © COPYRIGHT 2004 BY TYCO ELECTRONICS CORPORATION. ALL RIGHTS RESERVED.

LOC	DIST	REVISIONS					
AP	-	P	LTR	DESCRIPTION	DATE	DWN	APVD
		B2		REVISED BY ECO-07-026675	22NOV2007	NCL	MR
		B3		REVISED BY ECO 07-028165	03DEC2007	EGS	PLF
		C		REVISED BY ECO 09-015721	22OCT2009	ABA	MR

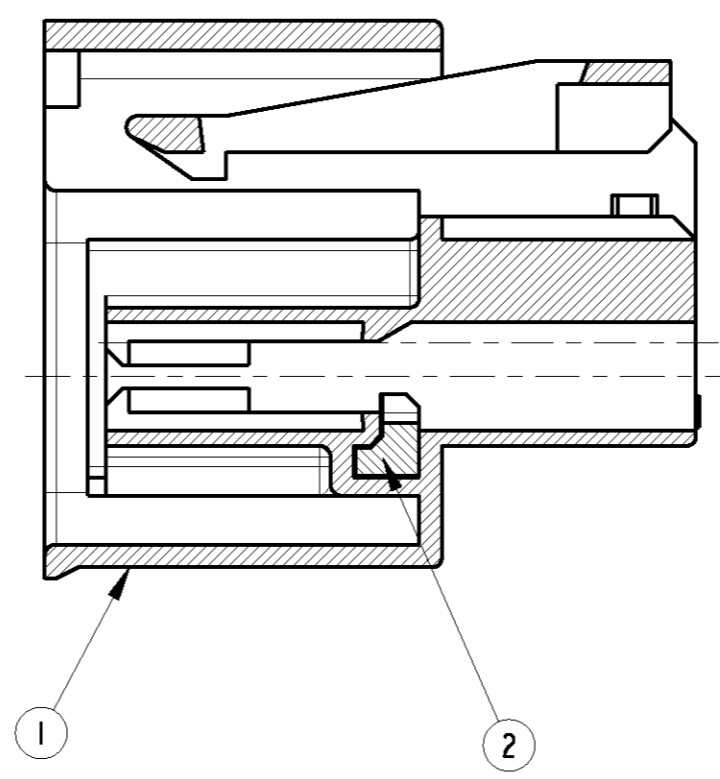

SECTION A-A

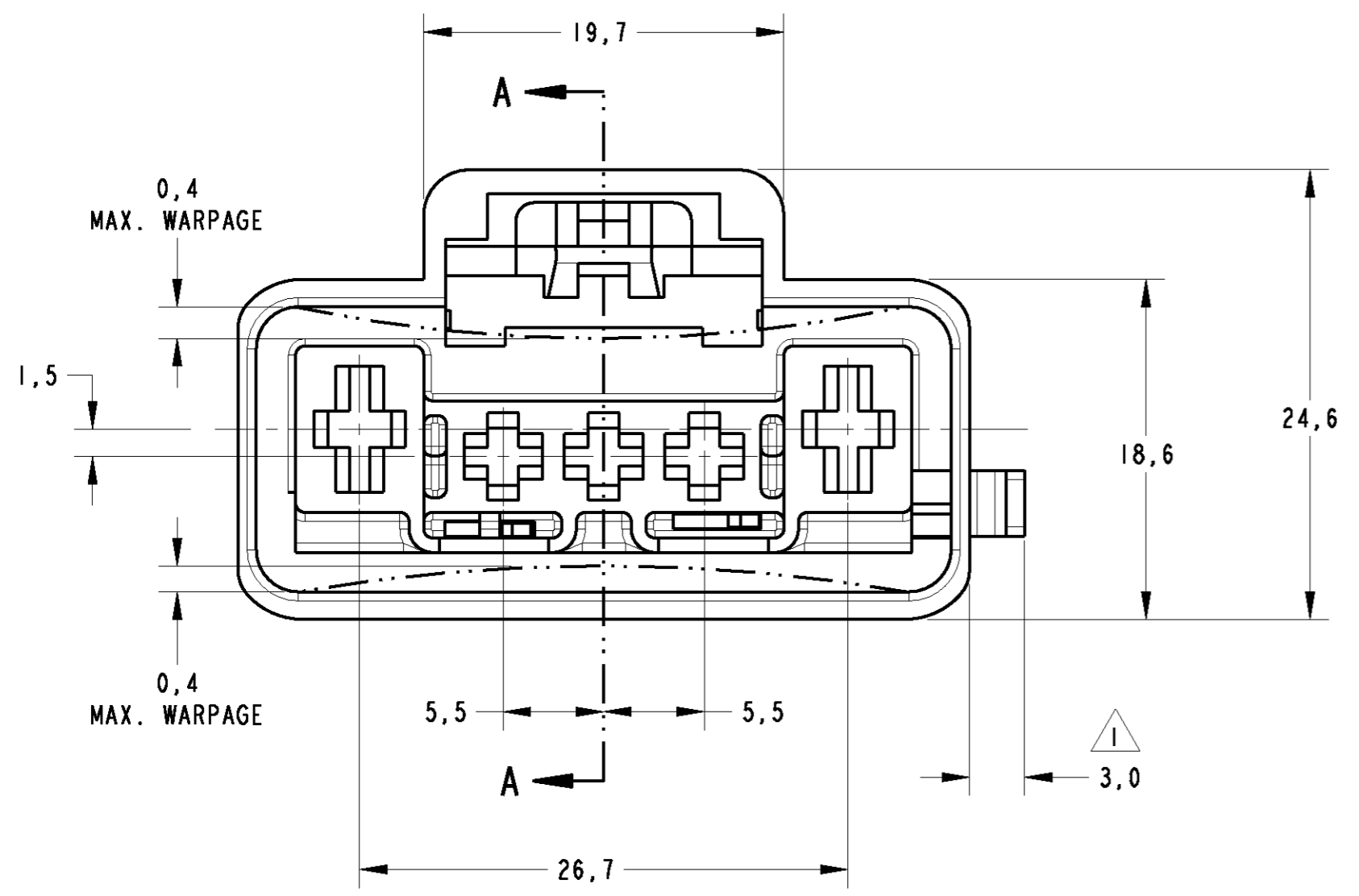
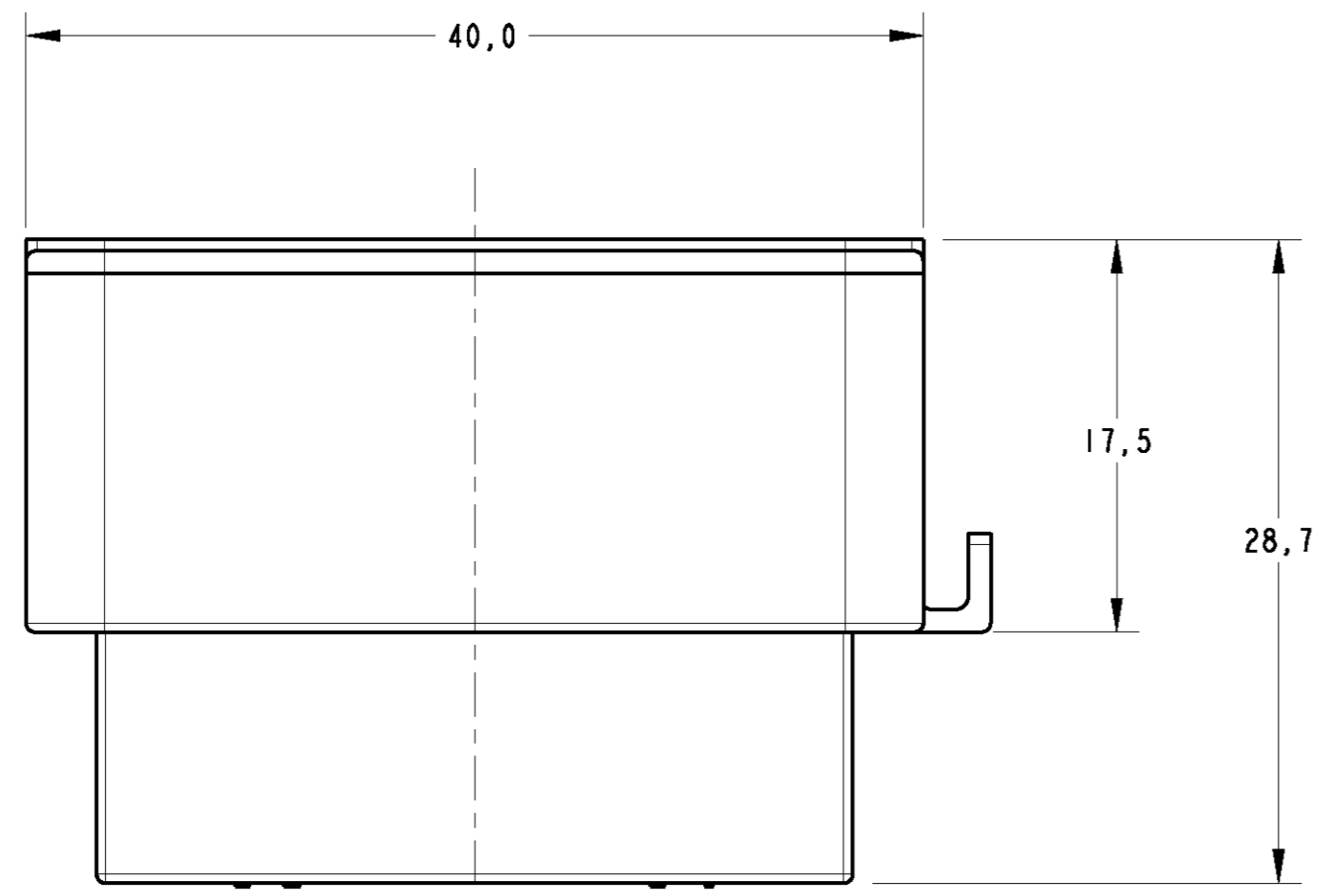
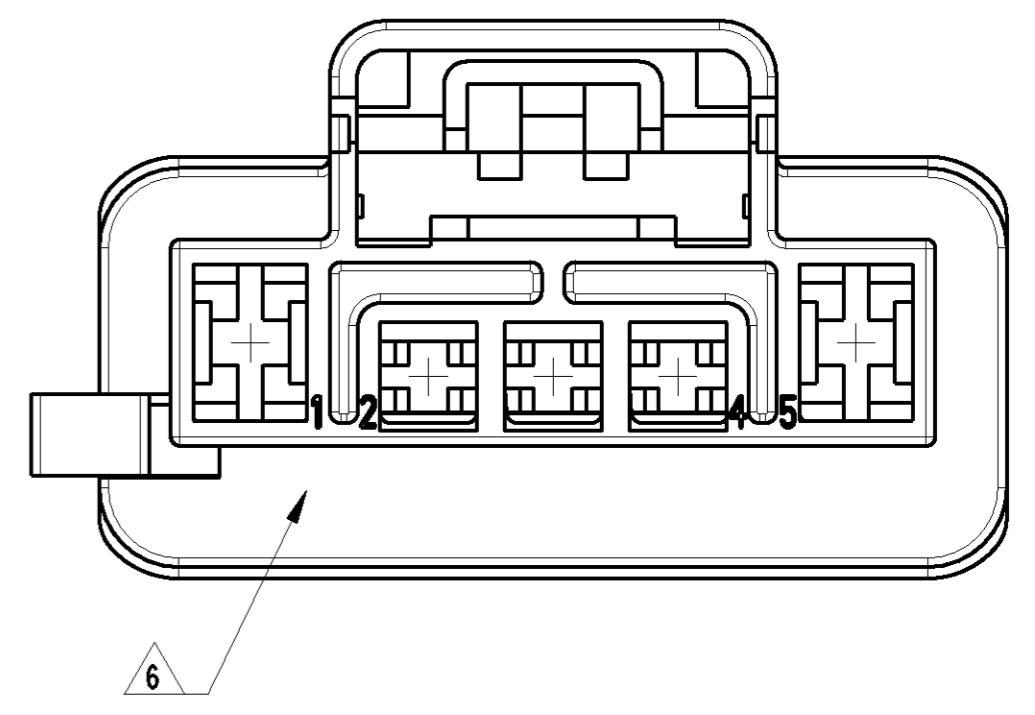

GRAVAÇÃO MARKING	
LOGOTIPO	TE LOGO
CÓDIGO PAÍS PRODUTOR	MANUFACTURER COUNTRY CODE
NOMENCLATURA MATERIAL	MATERIAL NOMENCLATURE
NÚMERO COMPONENTE TE	TE COMPONENT NUMBER
NÚMERO CAVIDADE	CAVITY NUMBER
PAÍS PRODUTOR	MANUFACTURER COUNTRY
REV+ LETRA REV. DA PEÇA	REV. + PART REV. LETTER
IDENTIFICAÇÃO DO CIRCUITO	CIRCUIT IDENTIFICATION

- 1 - POSIÇÃO DE PRÉ TRAVAMENTO DA TRAVA SECUNDÁRIA, FORNECIDO CONFORME MOSTRADO. / - PRE LOCK POSITION OF SECONDARY LOCK, SUPPLIED AS SHOWN.
- 2 - TERMINAIS: JPT - VIDE DESENHO GRUPO DE PRODUTO - C 1355047 / SPT - VIDE DESENHO GRUPO DE PRODUTO - C 1355048 / 2 - TERMINALS: JPT - SEE PRODUCT GROUP DRAWING - C 1355047 / SPT - SEE PRODUCT GROUP DRAWING - C 1355048
- 3 - PARA DETALHE DA CONTRA PEÇA VIDE FOLHA 2 DE 2 / 3 - FOR COUNTER PART DETAIL SHEET 2 OF 2.
- 4 - MATERIAL CONECTOR - PA 6.6 +15%GF / 4 - CONNECTOR MATERIAL - PA 6.6 +15GF
- 5 - MATERIAL / ACABAMENTO DOS TABS: BRONZE FOSFOROSO / ESTANHADO / 5 - TABS MATERIAL / FINISH: PHOSP. BRONZE / TIN PLATED

REQ. PER ASSY	ITEM	DESCRIPTION	MATERIAL	FINISH
2	2	SECONDARY LOCK, 5 POS HYBRID SPT/JPT, REC	>PA6.6+15%GF<	AZUL / BLUE
1	1	HOUSING, 5 POS HYBRID SPT/JPT, REC	>PA6.6+15%GF<	PRETO / BLACK

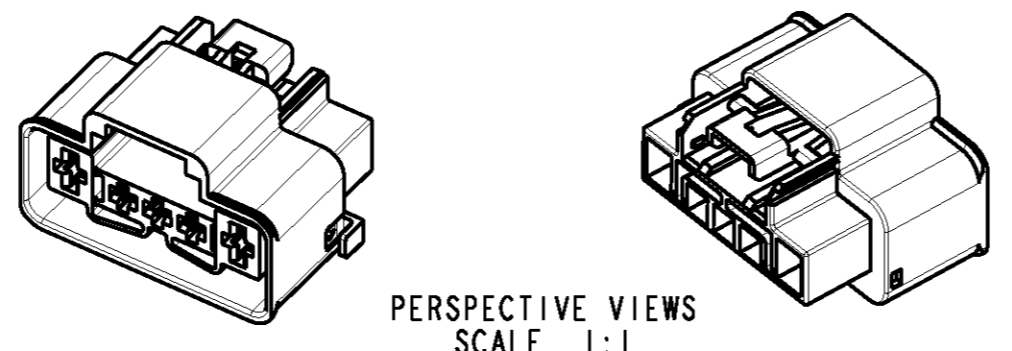

PERSPECTIVE VIEWS SCALE 1:1

DIMENSIONS: mm 		TOLERANCES UNLESS OTHERWISE SPECIFIED: 0 PLC ± 1 PLC ±0.3 2 PLC ± 3 PLC ± 4 PLC ± ANGLES ±° FINISH SEE TABLE		DWN E.J.G.SILVA 31OCT2007 CHK P.L.FARIA 31OCT2007 APVD I.W.PRADO 31OCT2007	Tyco Electronics TYCO ELECTRONICS do Brasil LTDA. São Paulo, Brasil
MATERIAL SEE TABLE		PRODUCT SPEC 108-37065 APPLICATION SPEC 411-37040 WEIGHT -/-		NAME HOUSING ASSEMBLY, 5 POS HYBRID SPT/JPT, REC SIZE A2 CAGE CODE 00779 DRAWING NO. C-1599317 RESTRICTED TO -/-	
CUSTOMER DRAWING				SCALE 3:1	SHEET 1 OF 2 REV C

1599317

THIS DRAWING IS UNPUBLISHED. RELEASED FOR PUBLICATION 2004
 © COPYRIGHT 2004 BY TYCO ELECTRONICS CORPORATION. ALL RIGHTS RESERVED.

LOC		DIST		REVISIONS				
AP	-	P	LTR	DESCRIPTION	DATE	DWN	APVD	
		-		SEE SHEET 1	-	-	-	

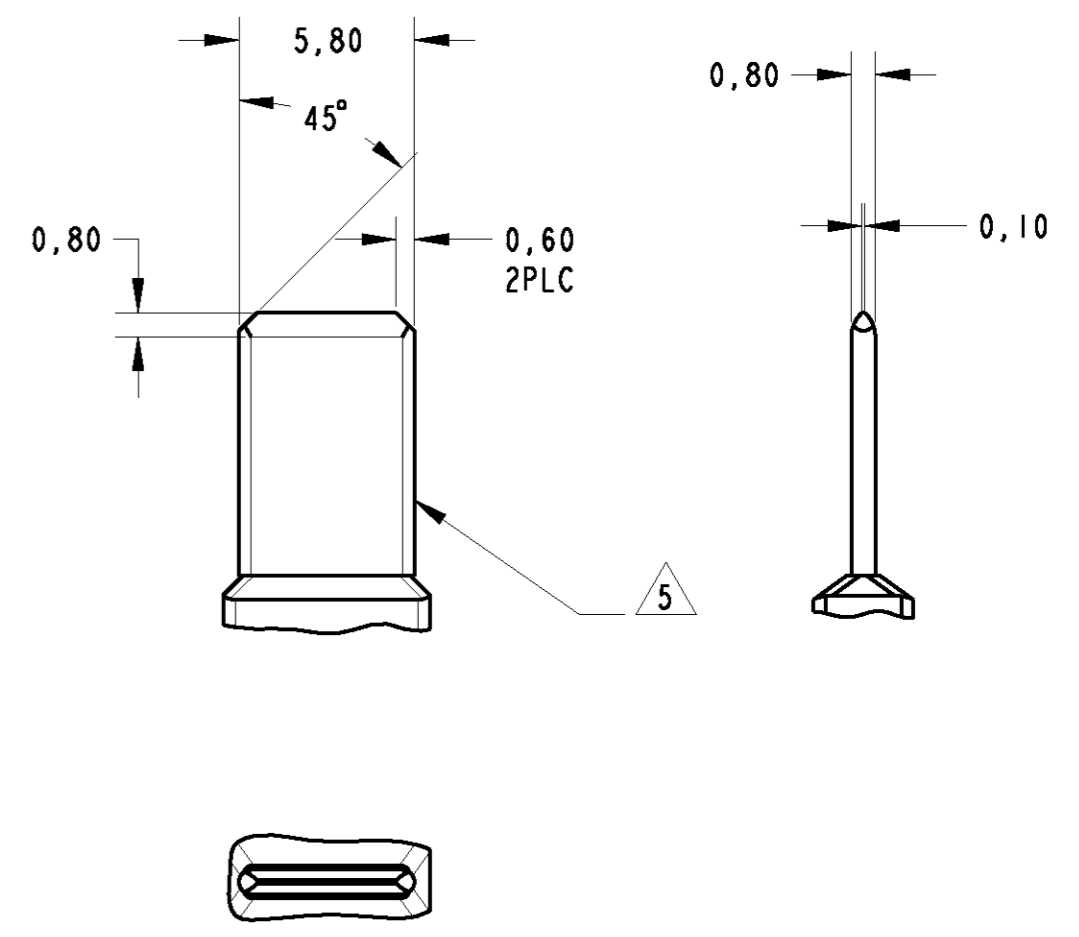
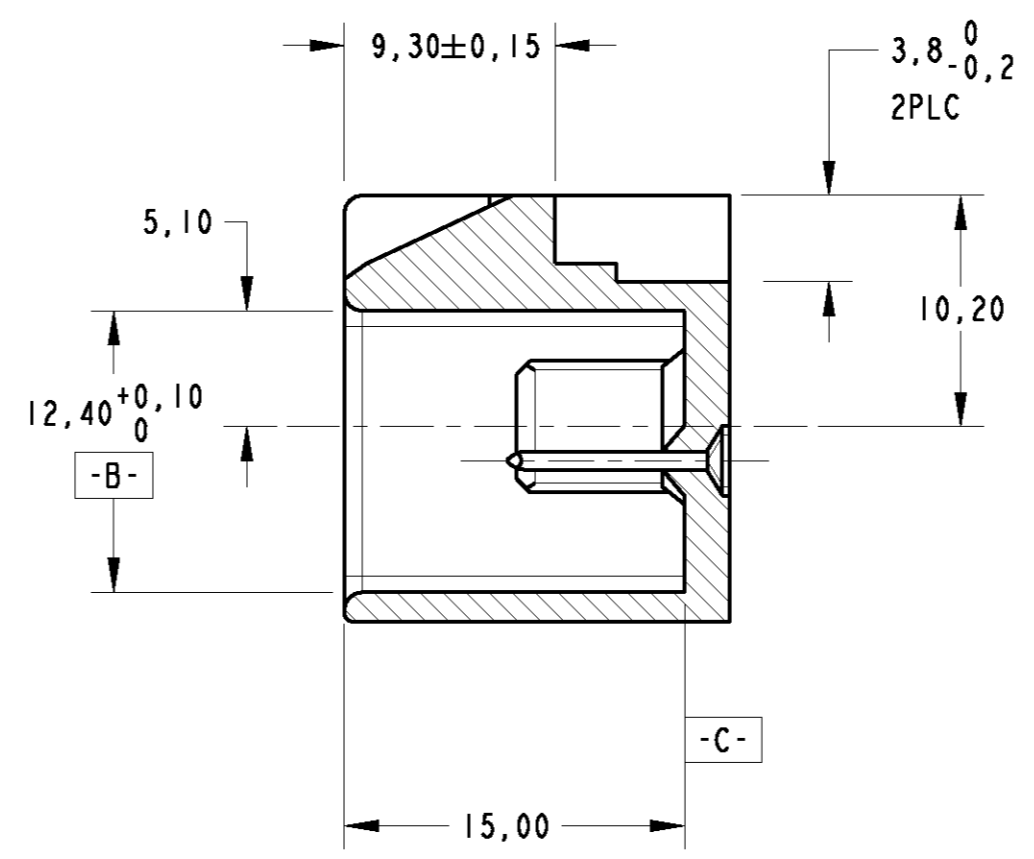
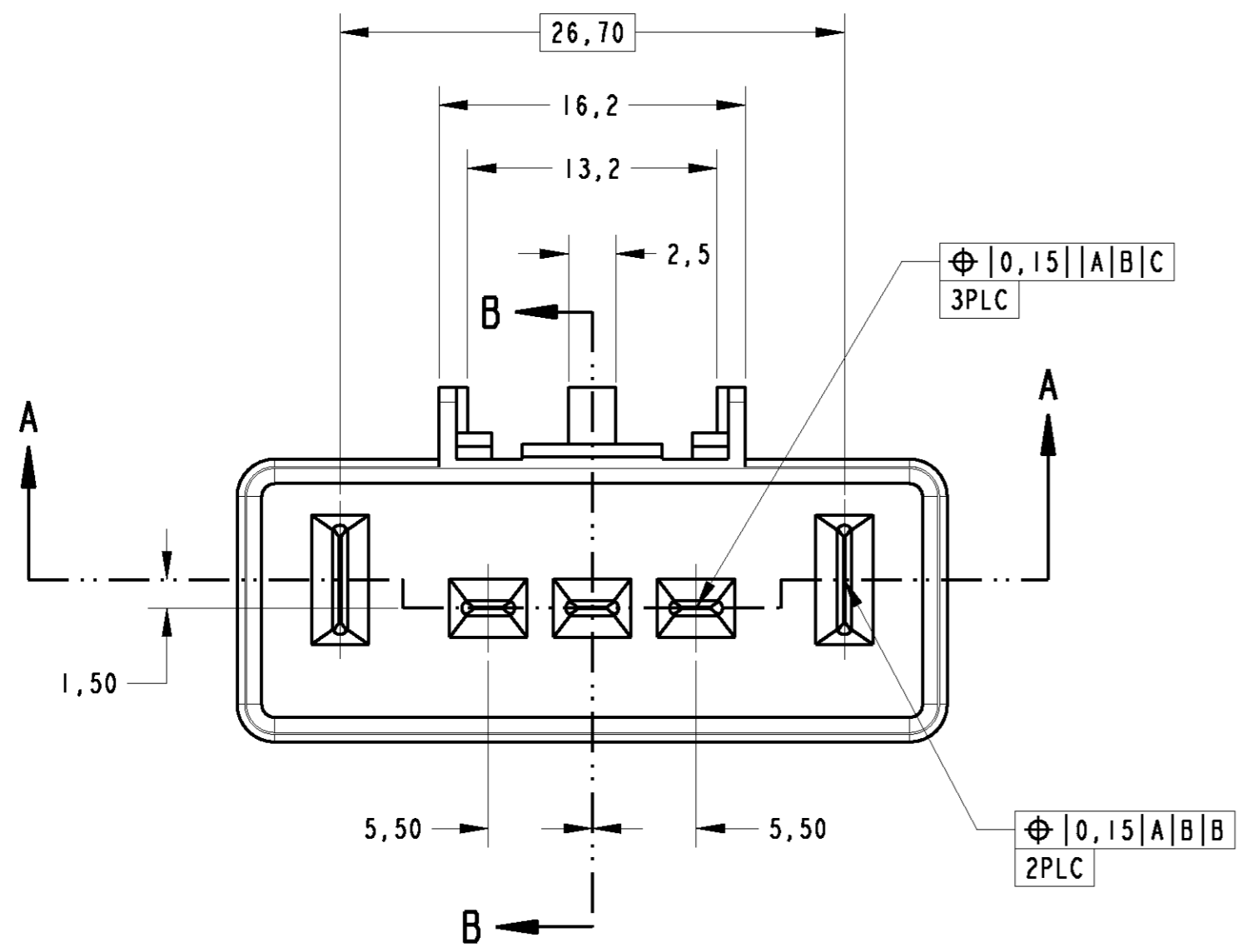

DIMENSION TAB SPT
SCALE 4:1

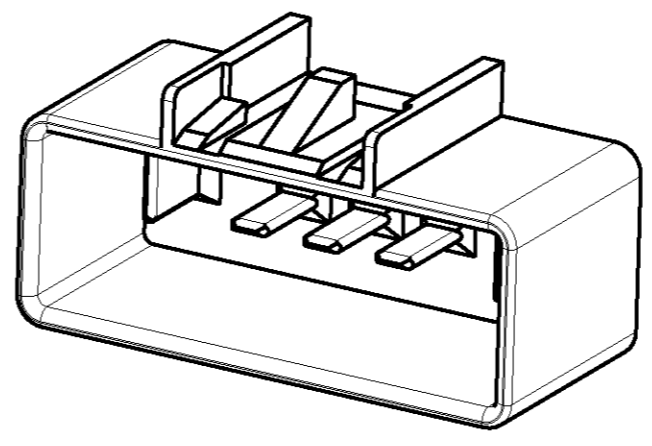
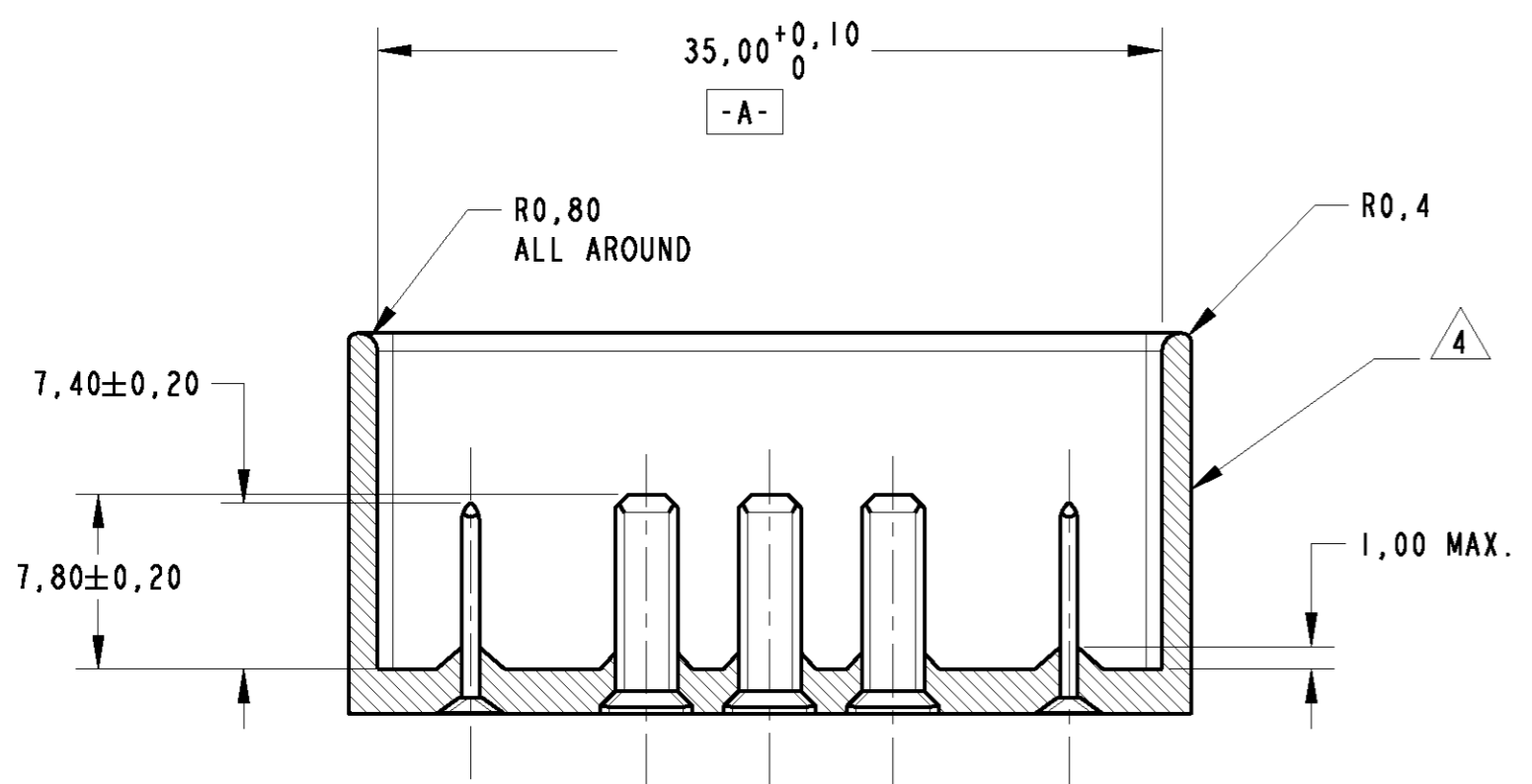

PERSPECTIVE VIEW

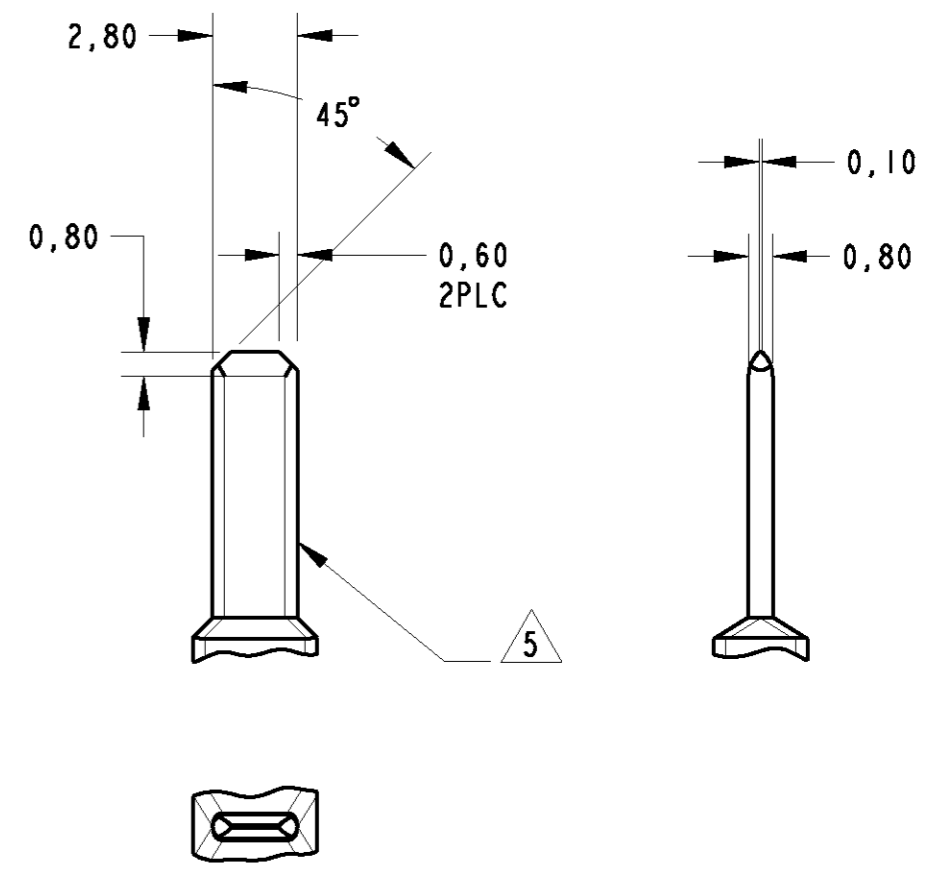

DIMENSION TAB JPT
SCALE 4:1

SECTION A-A

THIS DRAWING IS A CONTROLLED DOCUMENT FOR TYCO ELECTRONICS CORPORATION IT IS SUBJECT TO CHANGE AND THE CONTROLLING ENGINEERING ORGANIZATION SHOULD BE CONTACTED FOR THE LATEST REVISION.		DWN 31OCT2007 E. J. G. SILVA CHK 31OCT2007 P. L. FARIA APVD 31OCT2007 I. W. PRADO	Tyco Electronics TYCO ELECTRONICS do Brasil LTDA. São Paulo, Brasil
DIMENSIONS: mm 		TOLERANCES UNLESS OTHERWISE SPECIFIED: 0 PLC ± 1 PLC ±0,3 2 PLC ± 3 PLC ± 4 PLC ± ANGLES ±° FINISH SEE TABLE	NAME HOUSING ASSEMBLY, 5 POS HYBRID SPT/JPT, REC
MATERIAL SEE TABLE		PRODUCT SPEC 108-37065 APPLICATION SPEC 411-37040 WEIGHT -/-	SIZE A2 CAGE CODE 00779 DRAWING NO. C-1599317 RESTRICTED TO -/-
CUSTOMER DRAWING		SCALE 3:1	SHEET 2 OF 2 REV C