

SPECIFICATIONS



Model Number: MDD48B1-E3
Part Number: 17001212A

Version: 01
Jun 13, 2018

Mechanical Drawing:

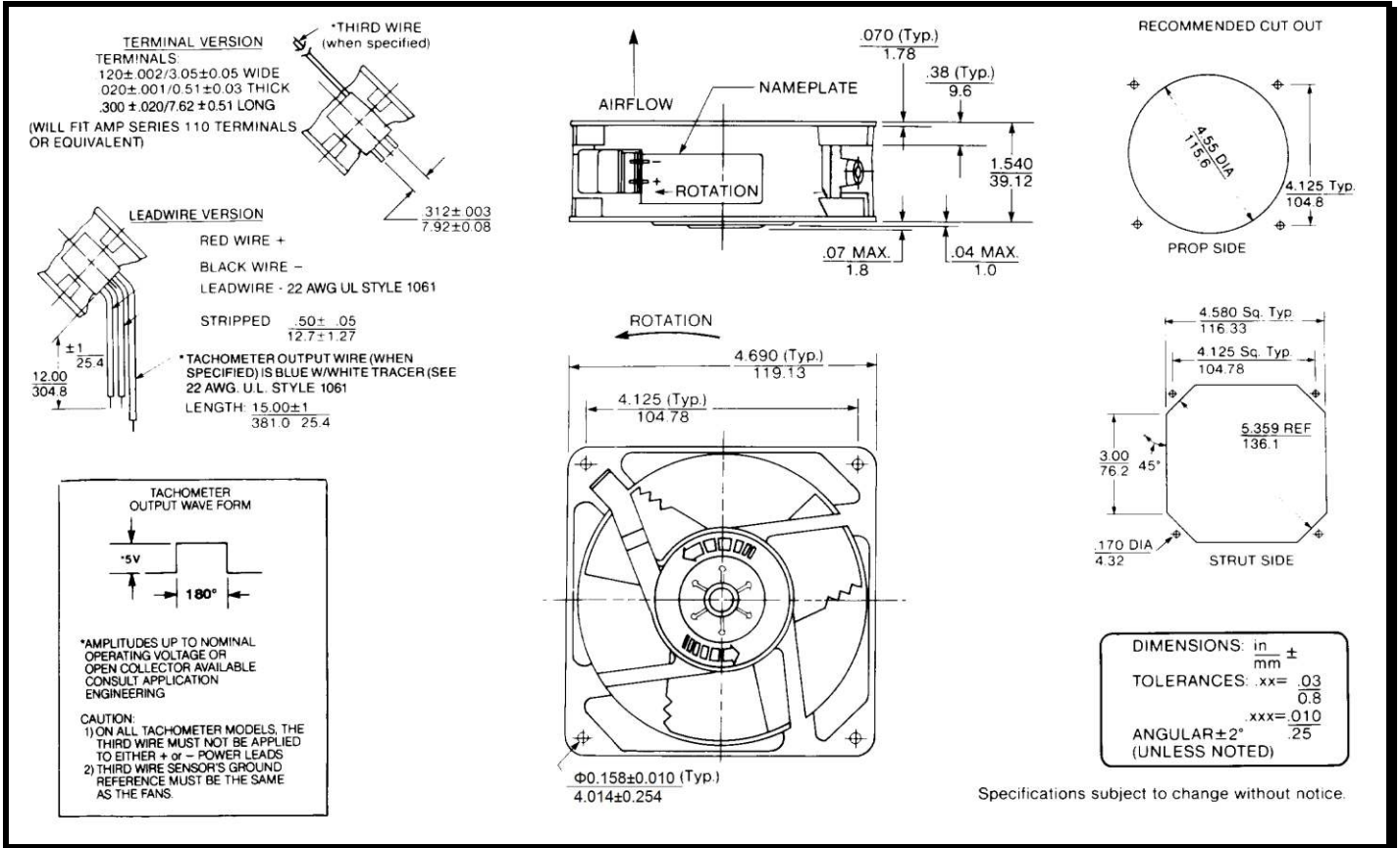

Motor:

Nominal Voltage = 48 vdc
 Operating Voltage Range = 36 - 60vdc
 Nominal Running Current = 0.12 amps
 Locked Rotor Current = 0.50 amps
 Running Power = 5.8 watts
 Average Speed = 3100 rpm
 Bearings = Ball
 Air Flow = 106 CFM
 Acoustic = 50 dBA

Construction:

Venturi: Die-Cast Aluminum, Black
 Propeller: Plastic, Black, UL 94V-0

Life Expectancy:

This fan is designed for continuous duty life of 55,000 hours at 70°C.

Additional Features:

Brushless DC Motor
 Electronic Locked Rotor Protection
 Automatic Restart Capability
 Polarity Protected
 Operating Temperature -10°C to 70°C
 Storage Temperature -40°C to 85°C
 Environmental Protection: Type 3(IP68)

Termination:

12" Lead wires, AWG 22, UL 1061
 Red - Fan Power (+)
 Black - Fan Ground (-)

Agency Approvals:

UL, CUL, CE

PQ Curve:

