

# TPS61094 60-nA Quiescent Current Boost Converter with Supercap Management

## 1 Features

- Wide voltage range and current range
  - 0.7-V to 5.5-V input voltage range
  - 1.8-V minimum input voltage for start-up
  - Programmable boost output voltages, 2.7-V to 5.4-V setting range
  - Programmable buck charging termination voltages, 1.7-V to 5.4-V setting range
  - Programmable buck charging output currents, 2.5-mA to 600-mA setting range
- Ultra-low quiescent current
  - 60 nA in boost mode or buck charging mode
  - 4 nA in forced bypass mode
- High efficiency and power capability
  - Typical 2.0-A inductor valley current limit
  - Two 60-mΩ (LS) / 140-mΩ (HS) MOSFETs
  - 100-mΩ bypass switch resistance
  - 1-MHz switching frequency
  - Auto snooze mode operation at light load
  - Up to 92.3% efficiency at  $V_{IN} = 3\text{ V}$ ,  $V_{OUT} = 3.6\text{ V}$ , and  $I_{OUT} = 10\text{ }\mu\text{A}$
  - Up to 96.3% efficiency at  $V_{IN} = 3\text{ V}$ ,  $V_{OUT} = 3.6\text{ V}$ , and  $I_{OUT} = 100\text{ mA}$
- Four operation modes controlled by the MODE and EN pins
- Rich protection
  - Output short-circuit protection
  - Thermal shutdown protection
- 2-mm × 3-mm 12-pin WSON package

## 2 Applications

- [Gas meter, water meter](#)
- [Portable medical equipment](#)
- [Energy harvest](#)

## 3 Description

The TPS61094 is a 60-nA  $I_Q$  boost converter with supercap management. The device provides a power supply solution for smart meter and super capacitor backup power applications.

The TPS61094 has a wide input voltage range and output voltage up to 5.5 V. When the TPS61094 works in buck mode and charges the supercap, the charging current and the termination voltage are programmable with two external resistors. When the TPS61094 works in boost mode, the output voltage is programmable with an external resistor.

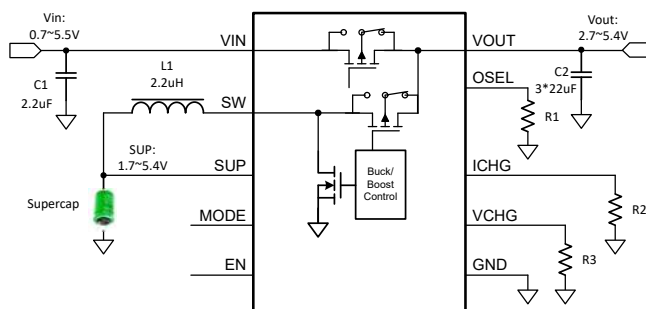
During automatic buck or boost mode (EN = 1, MODE = 1), when the input power supply is applied, the device bypasses the input voltage to the output while it is capable of charging a backup supercap. When the input power supply is disconnected or lower than the output target voltage, the TPS61094 enters boost mode and regulates output voltage from a backup supercap. The TPS61094 consumes 60-nA quiescent current in this mode.

The TPS61094 supports true shutdown mode (EN = 0, MODE = 1) and the forced bypass mode (EN = 0, MODE = 0). In true shutdown mode, the TPS61094 completely disconnects the load from the input supply. When supporting forced bypass mode, the TPS61094 connects the load to the input voltage directly through a bypass switch and only consumes 4-nA current to achieve long battery life.

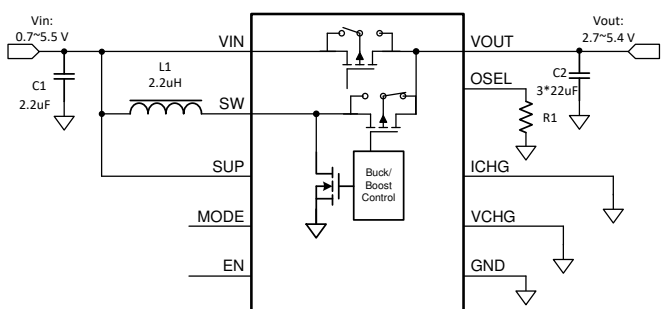
### Device Information

PART NUMBER	PACKAGE <sup>(1)</sup>	BODY SIZE (NOM)
TPS61094	WSON (12)	2.0 mm × 3.0 mm

(1) For all available packages, see the orderable addendum at the end of the data sheet.



Typical Application Circuit 1



Typical Application Circuit 2



## Table of Contents

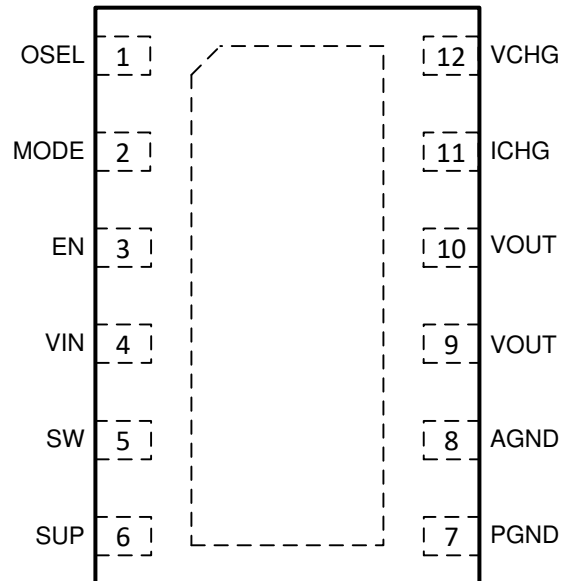
<b>1 Features</b> .....	1	8.1 Application Information.....	21
<b>2 Applications</b> .....	1	8.2 Typical Application – 3.6-V Output Boost Converter with Bypass.....	21
<b>3 Description</b> .....	1	<b>9 Power Supply Recommendations</b> .....	29
<b>4 Revision History</b> .....	2	<b>10 Layout</b> .....	30
<b>5 Pin Configuration and Functions</b> .....	3	10.1 Layout Guidelines.....	30
<b>6 Specifications</b> .....	4	10.2 Layout Example.....	30
6.1 Absolute Maximum Ratings .....	4	<b>11 Device and Documentation Support</b> .....	32
6.2 ESD Ratings .....	4	11.1 Device Support.....	32
6.3 Recommended Operating Conditions .....	4	11.2 Documentation Support.....	32
6.4 Thermal Information .....	4	11.3 Receiving Notification of Documentation Updates..	32
6.5 Electrical Characteristics .....	5	11.4 Support Resources.....	32
6.6 Typical Characteristics.....	8	11.5 Trademarks.....	32
<b>7 Detailed Description</b> .....	10	11.6 Electrostatic Discharge Caution.....	32
7.1 Overview.....	10	11.7 Glossary.....	32
7.2 Functional Block Diagram.....	12	<b>12 Mechanical, Packaging, and Orderable Information</b> .....	33
7.3 Feature Description.....	12		
7.4 Device Functional Modes.....	15		
<b>8 Application and Implementation</b> .....	21		

## 4 Revision History

Changes from Revision B (September 2021) to Revision C (December 2021)	Page
• Changed the title .....	1
• Updated the typical application.....	1
• Changed "Minimum 1.4-A inductor valley current limit" to "Typical 2.0-A inductor valley current".....	1
• Updated <a href="#">Section 3</a> .....	1
• Add the description about the quiescent current at pass through mode.....	18

Changes from Revision A (February 2021) to Revision B (September 2021)	Page
• Changed document status from Advance Information to Production Data.....	1

## 5 Pin Configuration and Functions



**Figure 5-1. 12-Pin WSON DSS Package (Top View)**

**Table 5-1. Pin Functions**

PIN		I/O <sup>(1)</sup>	DESCRIPTION
NO.	NAME		
1	OSEL	I	Boost output voltage selection pin. Connect a resistor between this pin and ground to select one of sixteen output voltages of Boost mode.
2	MODE	I	Operation mode selection pin. The MODE pin and EN pin work together to set device operation mode. See <a href="#">Table 7-4</a> .
3	EN	I	Operation mode selection pin. The MODE pin and EN pin work together to set device operation mode. See <a href="#">Table 7-4</a> .
4	VIN	PWR	IC power supply input
5	SW	PWR	The switching node pin of the converter. It is connected to the drain of the internal low-side power MOSFET and the source of the internal high-side power MOSFET.
6	SUP	I	Output of buck converter to sense the voltage of the supercap
7	PGND	PWR	Power ground
8	AGND	PWR	Signal ground
9, 10	VOUT	PWR	Output of the device
11	ICHG	I	Charging current selection pin. Connect a resistor between this pin and ground to select one of sixteen output currents of Buck mode.
12	VCHG	I	Charging voltage selection pin. Connect a resistor between this pin and ground to select one of sixteen regulation voltages of Buck mode.

(1) I = Input, PWR = Power

## 6 Specifications

### 6.1 Absolute Maximum Ratings

over operating free-air temperature range (unless otherwise noted)<sup>(1)</sup>

		MIN	MAX	UNIT
Voltage	VIN, VOUT, SW, SUP, MODE, EN, OSEL, VCHG, ICHG	-0.3	6.5	V
	SW spike at 10 ns	-0.7	8	
	SW spike at 1 ns	-0.7	9	
T <sub>J</sub>	Operating junction temperature	-40	125	°C
T <sub>stg</sub>	Storage temperature	-65	150	°C

- (1) Operation outside the *Absolute Maximum Ratings* may cause permanent device damage. *Absolute Maximum Ratings* do not imply functional operation of the device at these or any other conditions beyond those listed under *Recommended Operating Conditions*. If used outside the *Recommended Operating Conditions* but within the *Absolute Maximum Ratings*, the device may not be fully functional, and this may affect device reliability, functionality, performance, and shorten the device lifetime.

### 6.2 ESD Ratings

			VALUE	UNIT
V <sub>(ESD)</sub>	Electrostatic discharge	Human body model (HBM), per ANSI/ESDA/ JEDEC JS-001, all pins <sup>(1)</sup>	±2000	V
		Charged device model (CDM), per ANSI/ESDA/ JEDEC JS-002, all pins <sup>(2)</sup>	±500	

- (1) JEDEC document JEP155 states that 500-V HBM allows safe manufacturing with a standard ESD control process.  
 (2) JEDEC document JEP157 states that 250-V CDM allows safe manufacturing with a standard ESD control process.

### 6.3 Recommended Operating Conditions

over operating free-air temperature range (unless otherwise noted)

		MIN	NOM	MAX	UNIT
V <sub>IN</sub>	Input voltage	0.7		5.5	V
V <sub>OUT</sub>	Boost output voltage	1.8		5.4	V
V <sub>SUP</sub>	Buck output voltage	2.0		5.4	V
T <sub>J</sub>	Junction temperature	-40		125	°C
L	Effective inductance	0.7	2.2	2.86	μH
C <sub>IN</sub>	Effective input capacitance at the VIN pin	2.2			μF
C <sub>OUT</sub>	Effective output capacitance at the OUT pin	20	30		μF
C <sub>SUP</sub>	Effective output capacitance at the SUP pin	2.2			μF

### 6.4 Thermal Information

THERMAL METRIC <sup>(1)</sup>		TPS61094	TPS61094	UNIT
		DSS 12-PINS	DSS 12-PINS	
		Standard	EVM	
R <sub>θJA</sub>	Junction-to-ambient thermal resistance	58.4	55.3	°C/W
R <sub>θJC(top)</sub>	Junction-to-case (top) thermal resistance	23.0	N/A	°C/W
R <sub>θJB</sub>	Junction-to-board thermal resistance	55.6	N/A	°C/W
Ψ <sub>JT</sub>	Junction-to-top characterization parameter	1.6	1.5	°C/W
Y <sub>JB</sub>	Junction-to-board characterization parameter	22.9	22.3	°C/W
R <sub>θJC(bot)</sub>	Junction-to-case (bottom) thermal resistance	10.0	N/A	°C/W

- (1) For more information about traditional and new thermal metrics, see the [Semiconductor and IC Package Thermal Metrics](#) application report.

## 6.5 Electrical Characteristics

$T_J = -40^{\circ}\text{C}$  to  $125^{\circ}\text{C}$ ,  $V_{IN} = 2.0\text{ V}$ ,  $V_{OUT} = 3.6\text{ V}$ , and  $V_{SUP} = 2.0\text{ V}$ , with an  $2.2\text{-}\mu\text{H}$  inductor. Typical values are at  $T_J = 25^{\circ}\text{C}$  (unless otherwise noted)

PARAMETER		TEST CONDITIONS	MIN	TYP	MAX	UNIT
<b>POWER SUPPLY</b>						
$V_{IN}$	Input voltage range		0.7		5.5	V
$V_{IN\_UVLO}$	Undervoltage lockout (UVLO) threshold at the VIN pin	$V_{IN}$ rising, $T_J$ up to $85^{\circ}\text{C}$		1.7	1.8	V
$V_{SUP\_UVLO}$	Undervoltage lockout (UVLO) threshold at the SUP pin	$V_{SUP}$ rising		0.85		V
		$V_{SUP}$ falling		0.6	0.7	V
$I_{Q\_BOOST}$	Quiescent current into the VIN pin at Boost mode	IC enabled, no load, no switching, $V_{IN} = 0.7\text{ V}$ to $5.5\text{ V}$ , $V_{SUP} = V_{IN}$ , $V_{OUT} = V_{OUT\_REG} + 0.1\text{ V}$ , $T_J$ up to $85^{\circ}\text{C}$		1		nA
	Quiescent current into the VOUT pin at Boost mode	IC enabled, no load, no switching, $V_{OUT} = 1.8\text{ V}$ to $5.4\text{ V}$ , $T_J$ up to $85^{\circ}\text{C}$		60	300	nA
$I_{Q\_BUCK}$	Quiescent current into the VIN pin at Buck mode	IC enabled, no load, no switching, $V_{IN} = 1.8\text{ V}$ to $5.5\text{ V}$ , $V_{SUP} = V_{CHG\_REG} + 0.1\text{ V}$ , $T_J$ up to $85^{\circ}\text{C}$		60	300	nA
	Quiescent current into the SUP pin at Buck mode	IC enabled, no load, no switching, $V_{SUP} = 1.7\text{ V}$ to $5.4\text{ V}$ , $T_J$ up to $85^{\circ}\text{C}$		1		nA
$I_{Q\_BYPASS}$	Quiescent current into the VIN pin at Forced bypass mode	$V_{EN} = 0\text{ V}$ , $V_{MODE} = 0\text{ V}$ , no load, $V_{IN} = V_{SUP} = 1.8\text{ V}$ to $5.5\text{ V}$ , $T_J$ up to $85^{\circ}\text{C}$		2	50	nA
	Quiescent current into the SUP pin at Forced bypass mode	$V_{EN} = 0\text{ V}$ , $V_{MODE} = 0\text{ V}$ , no load, $V_{IN} = V_{SUP} = 1.8\text{ V}$ to $5.5\text{ V}$ , $T_J$ up to $85^{\circ}\text{C}$		2	50	nA
$I_{SD}$	Shutdown current into the VIN pin	IC disabled, $V_{IN} = 1.8\text{ V}$ to $5.5\text{ V}$ , $V_{OUT} = 0\text{ V}$ , $T_J$ up to $85^{\circ}\text{C}$		100	550	nA
	Shutdown current into the SUP pin	IC disabled, $V_{SUP} = 0.7\text{ V}$ to $5.5\text{ V}$ , $V_{OUT} = 0\text{ V}$ , $T_J$ up to $85^{\circ}\text{C}$		100	250	nA
$I_{LKG\_SW\_VOUT}$	Leakage current into the SW pin (from SW pin to VOUT)	$V_{IN} = 1.8\text{ V}$ , $V_{SW} = V_{SUP} = 1.8\text{ V}$ to $5.5\text{ V}$ , $V_{OUT} = 0\text{ V}$ , no switching, $T_J = 25^{\circ}\text{C}$		1	40	nA
		$V_{IN} = 1.8\text{ V}$ , $V_{SW} = V_{SUP} = 1.8\text{ V}$ to $5.5\text{ V}$ , $V_{OUT} = 0\text{ V}$ , no switching, $T_J$ up to $85^{\circ}\text{C}$		1	250	nA
$I_{LKG\_SW\_GND}$	Leakage current into the SW pin (from SW pin to GND)	$V_{IN} = 1.8\text{ V}$ , $V_{SW} = V_{SUP} = 1.8\text{ V}$ to $5.5\text{ V}$ , $V_{OUT} = V_{SW}$ , no switching, $T_J = 25^{\circ}\text{C}$		1	20	nA
		$V_{IN} = 1.8\text{ V}$ , $V_{SW} = V_{SUP} = 1.8\text{ V}$ to $5.5\text{ V}$ , $V_{OUT} = V_{SW}$ , no switching, $T_J$ up to $85^{\circ}\text{C}$		1	220	nA
<b>BOOST OUTPUT</b>						
$V_{OUT}$	Output voltage setting range	16 options	2.7		5.4	V
$V_{OUT\_UVLO}$	Undervoltage lockout (UVLO) threshold at the VOUT pin	$V_{OUT}$ rising	1.6	1.7	1.8	V
		$V_{OUT}$ falling	1.5	1.6	1.7	V
$V_{OUT\_PWM\_ACY}$	Output voltage accuracy in Boost mode	$V_{IN} = 1.8\text{ V}$ , PWM mode	-2%	0%	2%	
$V_{OUT\_PFM\_ACY}$		$V_{IN} = 1.8\text{ V}$ , PFM mode		$V_{OUT\_PW}$ $M\_ACY + 1\%$		
$V_{OUT\_SNOOZE\_ACY}$		$V_{IN} = 1.8\text{ V}$ , Snooze mode		$V_{OUT\_PW}$ $M\_ACY + 1.5\%$		
$I_{SHORT}$	Output short circuit current		190	300	500	mA
<b>BUCK OUTPUT</b>						
$V_{SUP}$	Charge voltage range	16 options	1.7		5.4	V

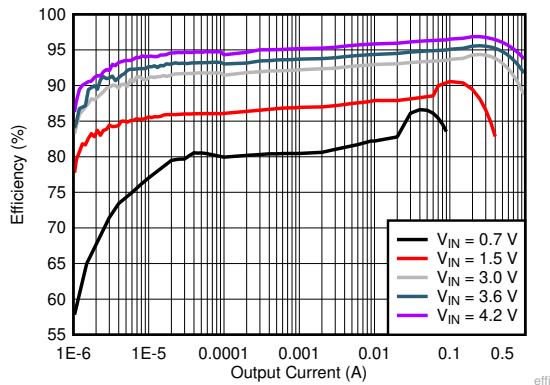
$T_J = -40^{\circ}\text{C}$  to  $125^{\circ}\text{C}$ ,  $V_{IN} = 2.0\text{ V}$ ,  $V_{OUT} = 3.6\text{ V}$ , and  $V_{SUP} = 2.0\text{ V}$ , with an  $2.2\text{-}\mu\text{H}$  inductor. Typical values are at  $T_J = 25^{\circ}\text{C}$  (unless otherwise noted)

PARAMETER		TEST CONDITIONS	MIN	TYP	MAX	UNIT
$V_{SUP\_ACY}$	Charge termination voltage accuracy in Buck mode		-2%	0%	2%	
$V_{SUP\_HYS}$	Charge termination voltage hysteresis in Buck mode		50	75	100	mV
$I_{CHG\_SET}$	Programmable charging current options	15 options; IC enabled, no load, $V_{IN} = 5\text{ V}$ , $V_{SUP} = 0.8\text{ V}$ to $4\text{ V}$ , $T_J$ up to $85^{\circ}\text{C}$	2.5		600	mA
$I_{CHG\_ACY}$	ICHG setting charging current accuracy	$ICHG = 2.5\text{ mA}$ or $5\text{ mA}$ ; $V_{IN} = 5\text{ V}$ , $V_{SUP} = 0.8\text{ V}$ to $4\text{ V}$	-2	0	2	mA
		$ICHG \geq 10\text{ mA}$ ; $V_{IN} = 5\text{ V}$ , $V_{SUP} = 0.8\text{ V}$ to $4\text{ V}$	-20%	0%	20%	
$I_{CHG\_TERM}$	Terminate charging current at $ICHG \geq 10\text{ mA}$	IC enabled, no load, $V_{IN} = 1.8\text{ V}$ to $5.5\text{ V}$ , $ICHG \geq 10\text{ mA}$ , $V_{SUP} > V_{CHG} - 50\text{ mV}$ , $T_J$ up to $85^{\circ}\text{C}$		10		mA
	Terminate charging current at $ICHG < 10\text{ mA}$	IC enabled, no load, $V_{IN} = 1.8\text{ V}$ to $5.5\text{ V}$ , $ICHG = 2.5\text{ mA}$ or $5\text{ mA}$ , $V_{SUP} > V_{CHG} - 50\text{ mV}$ , $T_J$ up to $85^{\circ}\text{C}$		2.5		mA
<b>POWER SWITCH</b>						
$R_{DS(on)\_HS}$	High-side FET on resistance	$V_{OUT} = 5.0\text{ V}$		150		m $\Omega$
		$V_{OUT} = 3.6\text{ V}$		180		m $\Omega$
$R_{DS(on)\_LS}$	Low-side FET on resistance	$V_{OUT} = 5.0\text{ V}$		60		m $\Omega$
		$V_{OUT} = 3.6\text{ V}$		70		m $\Omega$
$R_{DS(on)\_BYP}$	Bypass FET on resistance	$V_{OUT} = 5.0\text{ V}$		120		m $\Omega$
		$V_{OUT} = 3.6\text{ V}$		150		m $\Omega$
<b>CURRENT LIMIT</b>						
$I_{SW\_LIM}$	High side switch valley current limit in Boost mode		1.7	2	2.6	A
	High side switch peak current limit in Buck mode			2.5		A
$I_{PEAK}$	Inductor peak current at PFM	$ICHG = 2.5\text{ mA}$ or $5\text{ mA}$ , $V_{SUP} > 0.8\text{ V}$		250		mA
		$10\text{ mA} \leq ICHG \leq 250\text{ mA}$ , $V_{SUP} > 0.8\text{ V}$		500		mA
$I_{SS}$	Pre-charge current at soft start	$V_{IN} = 1.8\text{ V}$ to $5.5\text{ V}$ , $V_{OUT} < 0.4\text{ V}$		300		mA
		$V_{IN} = 3.6\text{ V}$ , $V_{OUT} = 1.8\text{ V}$	500			mA
<b>SWITCHING FREQUENCY</b>						
$f_{SW\_BOOST}$	Switching frequency at Boost mode	$V_{IN} = V_{SUP} = 3.6\text{ V}$ , $V_{OUT} = 5.0\text{ V}$ , PWM mode		1		MHz
		$V_{IN} = V_{SUP} = 1\text{ V}$ , $V_{OUT} = 5.0\text{ V}$ , PWM mode		0.5		MHz
$t_{OFF\_MIN\_BOOST}$	Minimum off time at Boost mode	$V_{OUT} = 5.0\text{ V}$		80	140	ns
$f_{SW\_BUCK}$	Switching frequency at Buck mode	$V_{SUP} = 3.6\text{ V}$ , $V_{IN} = V_{OUT} = 5.0\text{ V}$ , PWM mode		1		MHz
<b>VOLTAGE MONITORING</b>						
$V_{BYPASS}$	Enter Bypass mode when $V_{IN} \geq V_{OUT\_TARGET} + V_{BY\_PASS}$		50	100	150	mV
$V_{BYPASS\_HYS}$	Hysteresis of $V_{BYPASS}$			50		mV
$V_{PASS\_THROUGH}$	Enter Pass-through mode when $V_{SUP} \geq V_{OUT} + V_{PASS\_THROUGH}$			-30		mV
	Exit Pass-through mode when $V_{SUP} < V_{OUT\_TARGET} + V_{PASS\_THROUGH}$			-100		mV
<b>LOGIC INTERFACE</b>						

$T_J = -40^{\circ}\text{C}$  to  $125^{\circ}\text{C}$ ,  $V_{IN} = 2.0\text{ V}$ ,  $V_{OUT} = 3.6\text{ V}$ , and  $V_{SUP} = 2.0\text{ V}$ , with an  $2.2\text{-}\mu\text{H}$  inductor. Typical values are at  $T_J = 25^{\circ}\text{C}$  (unless otherwise noted)

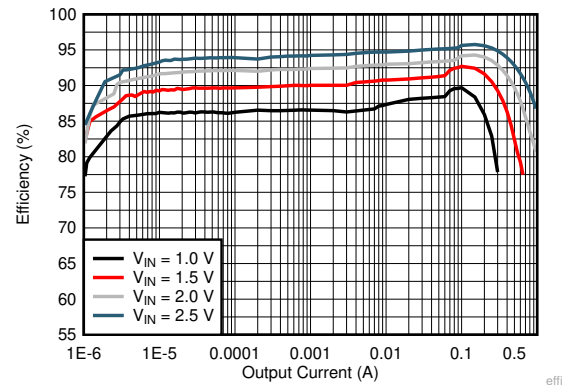
PARAMETER		TEST CONDITIONS	MIN	TYP	MAX	UNIT
$V_{EN\_H}$	EN logic high threshold	$V_{OUT} > 1.8\text{ V}$			0.58	V
		$V_{OUT} < 1.8\text{ V}$			1.0	V
$V_{EN\_L}$	EN logic low threshold	$V_{OUT} > 1.8\text{ V}$	0.2			V
		$V_{OUT} < 1.8\text{ V}$	0.45			V
$I_{EN\_LKG}$	Leakage current into the EN pin	$V_{EN} = 1.2\text{ V}$ , $T_J$ up to $85^{\circ}\text{C}$		1		nA
$R_{EN}$	EN pin pulldown resistor	$V_{EN} = 0\text{ V}$ , $T_J$ up to $85^{\circ}\text{C}$		800		k $\Omega$
$V_{MODE\_H}$	MODE logic high threshold	$V_{OUT} > 1.8\text{ V}$			0.58	V
		$V_{OUT} < 1.8\text{ V}$			1.0	V
$V_{MODE\_L}$	MODE logic low threshold	$V_{OUT} > 1.8\text{ V}$	0.2			V
		$V_{OUT} < 1.8\text{ V}$	0.45			V
$I_{MODE\_LKG}$	Leakage current into MODE pin	$V_{MODE} = 1.2\text{ V}$ , $T_J$ up to $85^{\circ}\text{C}$		1		nA
$R_{MODE}$	MODE pin pulldown resistor	$V_{MODE} = 0\text{ V}$ , $T_J$ up to $85^{\circ}\text{C}$		800		k $\Omega$
<b>PROTECTION</b>						
$T_{SD}$	Thermal shutdown	Junction temperature rising		150		$^{\circ}\text{C}$
$T_{SD\_HYS}$	Thermal shutdown hysteresis	Junction temperature falling below $T_{SD}$		20		$^{\circ}\text{C}$

## 6.6 Typical Characteristics



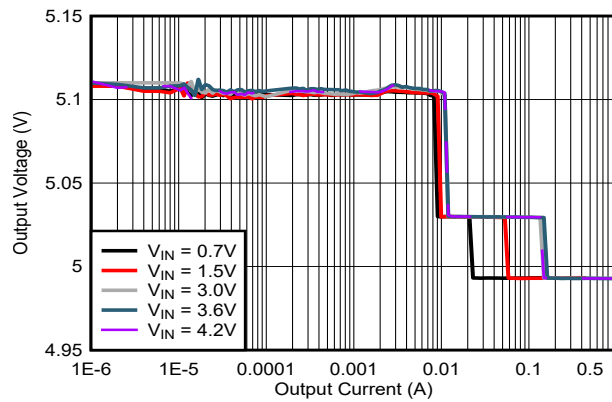
$V_{IN} = 0.7\text{ V}, 1.5\text{ V}, 3.0\text{ V}, 3.6\text{ V}, 4.2\text{ V}$        $V_{OUT} = 5.0\text{ V}$

**Figure 6-1. 5.0-V  $V_{OUT}$  Efficiency with Different Inputs in Boost Operation**



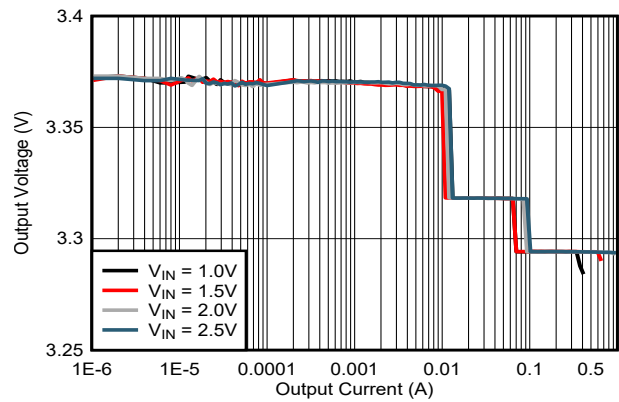
$V_{IN} = 1.0\text{ V}, 1.5\text{ V}, 2.0\text{ V}, 2.5\text{ V}$        $V_{OUT} = 3.3\text{ V}$

**Figure 6-2. 3.3-V  $V_{OUT}$  Efficiency with Different Inputs in Boost Operation**



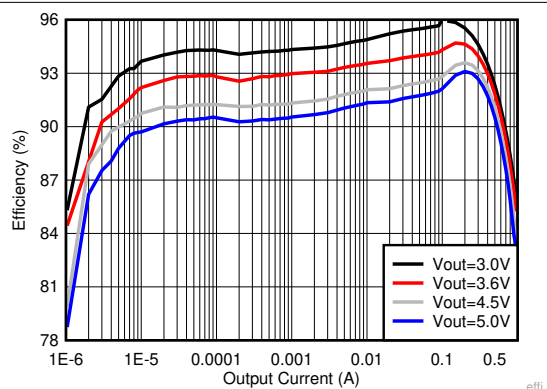
$V_{IN} = 0.7\text{ V}, 1.5\text{ V}, 3.0\text{ V}, 3.6\text{ V}, 4.2$        $V_{OUT} = 5.0\text{ V}$

**Figure 6-3. 5.0-V Load Regulation in Boost Operation**



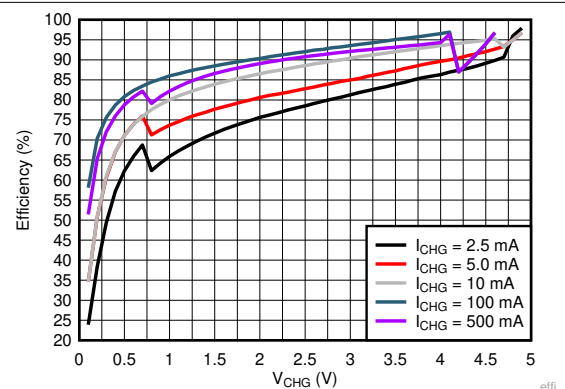
$V_{IN} = 1.0\text{ V}, 1.5\text{ V}, 2.0\text{ V}, 2.5\text{ V}$        $V_{OUT} = 3.3\text{ V}$

**Figure 6-4. 3.3-V Load Regulation in Boost Operation**



$V_{OUT} = 3.0\text{ V}, 3.6\text{ V}, 4.5\text{ V}, 5.0\text{ V}$        $V_{IN} = 2.7\text{ V}$

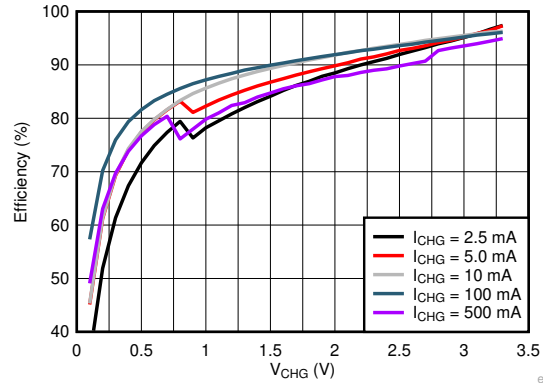
**Figure 6-5. Efficiency with Different Outputs in Boost Operation**



$I_{CHG} = 2.5\text{ mA}, 5.0\text{ mA}, 10\text{ mA}, 100\text{ mA}, 500\text{ mA}$        $V_{IN} = 5\text{ V}$

**Figure 6-6. 5-V Input Efficiency with Different Charging current in Buck Operation**





$I_{CHG} = 2.5 \text{ mA}, 5.0 \text{ mA}, 10 \text{ mA}, 100 \text{ mA}, 500 \text{ mA}$   $V_{IN} = 3.6 \text{ V}$

**Figure 6-7. 3.6V Input Efficiency with Different Charging current in Buck Operation**

## 7 Detailed Description

### 7.1 Overview

The TPS61094 is a 60-nA quiescent current synchronous bi-directional buck/boost converter with a bypass switch between the input and output. The TPS61094 can operate with a wide input voltage from 0.7 V to 5.5 V and output voltage from 2.7 V to 5.4 V. The device provides a ultra-low power solution optimized for applications that require ultra-low quiescent current, use a supercap or battery as a backup power supply, or both.

The TPS61094 has four operation modes by the EN pin and MODE pin selection:

- Auto buck or boost mode (EN = 1; MODE = 1)
- Forced buck mode (EN = 1; MODE = 0)
- Forced bypass mode (EN = 0; MODE = 0)
- True shutdown mode (EN = 0; MODE = 1)

In Auto buck or Boost mode, the TPS61094 can automatically transform between Buck charging mode and Boost mode based on the input voltage. When the input voltage is lower than the setting boost regulation voltage, the TPS61094 generates a regulation voltage from the low input voltage of a supercap or a battery. When the input voltage is 0.1 V higher than the setting boost regulation voltage, the output voltage of the TPS61094 equals the input voltage. Meanwhile, the TPS61094 charges the backup supercap by Buck mode.

When the TPS61094 works in Forced buck mode, the TPS61094 connects the output of the device directly to the input while the buck converter outputs a setting constant current charging a backup supercap. When the supercap is charged to a pre-set termination voltage, the buck converter stops charging. When the supercap voltage drops 75 mV below the setting voltage, the buck converter starts charging the supercap again.

In Forced bypass mode, the TPS61094 turns on the bypass MOSFET, thus the output voltage equals to input voltage. The TPS61094 has approximately 4-nA  $I_Q$  in this mode.

In True shutdown mode, the TPS61094 can disconnect the load from the input and SUP pin.

#### 7.1.1 The Configuration of VCHG Pin, ICHG Pin, and OSEL Pin

The TPS61094 supports sixteen internal setting options for charging termination voltage (VCHG), charging current (ICHG), and output voltage (OSEL) by connecting a resistor between the VCHG, ICHG, or OSEL pin and ground.

During start-up, when output voltage reaches close to input voltage, the device starts to detect the configuration conditions of the VCHG, ICHG, and OSEL pins (in that order). The TPS61094 checks the VCHG, ICHG, and OSEL pins by lowering setting options to higher setting options until the user finds the setting configuration by a 10- $\mu$ s clock. After detecting the configuration, the TPS61094 latches the charging current in Buck mode, the charging termination voltage in Buck mode, and the setting output regulation voltage in Boost mode. To save detection time, TI suggests shorting the VCHG and ICHG pins to ground when Buck mode is not used.

The TPS61094 does not detect the VCHG, ICHG, and OSEL pins during operation, so changing the resistor during operation does not change the VCHG, ICHG, and OSEL settings. Toggling the EN pin during operation is one way to refresh the VCHG, ICHG, and OSEL settings.

For proper operation, TI suggests that the setting resistance accuracy must be 1% and the parasitic capacity of the VCHG, ICHG, and OSEL pins should be less than 10 pF.

### 7.1.1.1 OSEL: Output Voltage Selection

In Boost mode operation, the device supports sixteen internally set output voltages by connecting a resistor between the OSEL pin and ground. [Table 7-1](#) lists the output voltage options with respect to resistance.

**Table 7-1. Output Voltage Options**

RESISTANCE (KΩ)	V <sub>OUT_REG</sub> (V)	RESISTANCE (KΩ)	V <sub>OUT_REG</sub> (V)	RESISTANCE (KΩ)	V <sub>OUT_REG</sub> (V)	RESISTANCE (KΩ)	V <sub>OUT_REG</sub> (V)
0	2.7	9.53	3.45	28.7	3.8	150	4.8
3.09	3.0	13.0	3.5	49.9	4.0	205	5.0
4.75	3.3	17.4	3.6	75.0	4.2	274	5.2
6.65	3.4	22.1	3.7	107	4.5	open	5.4

### 7.1.1.2 VCHG: Charging Termination Voltage Selection

In Buck mode operation, the device supports sixteen internally set charging termination voltages by connecting a resistor between the VCHG pin and ground. [Table 7-2](#) lists the termination voltage options with respect to resistance.

**Table 7-2. Charging Termination Voltage Options**

RESISTANCE (KΩ)	V <sub>CHG_REG</sub> (V)	RESISTANCE (KΩ)	V <sub>CHG_REG</sub> (V)	RESISTANCE (KΩ)	V <sub>CHG_REG</sub> (V)	RESISTANCE (KΩ)	V <sub>CHG_REG</sub> (V)
0	1.7	9.53	2.6	28.7	3.7	150	4.9
3.09	2.0	13.0	2.7	49.9	4.1	205	5.0
4.75	2.2	17.4	3.6	75.0	4.15	274	5.1
6.65	2.5	22.1	3.65	107	4.2	open	5.4

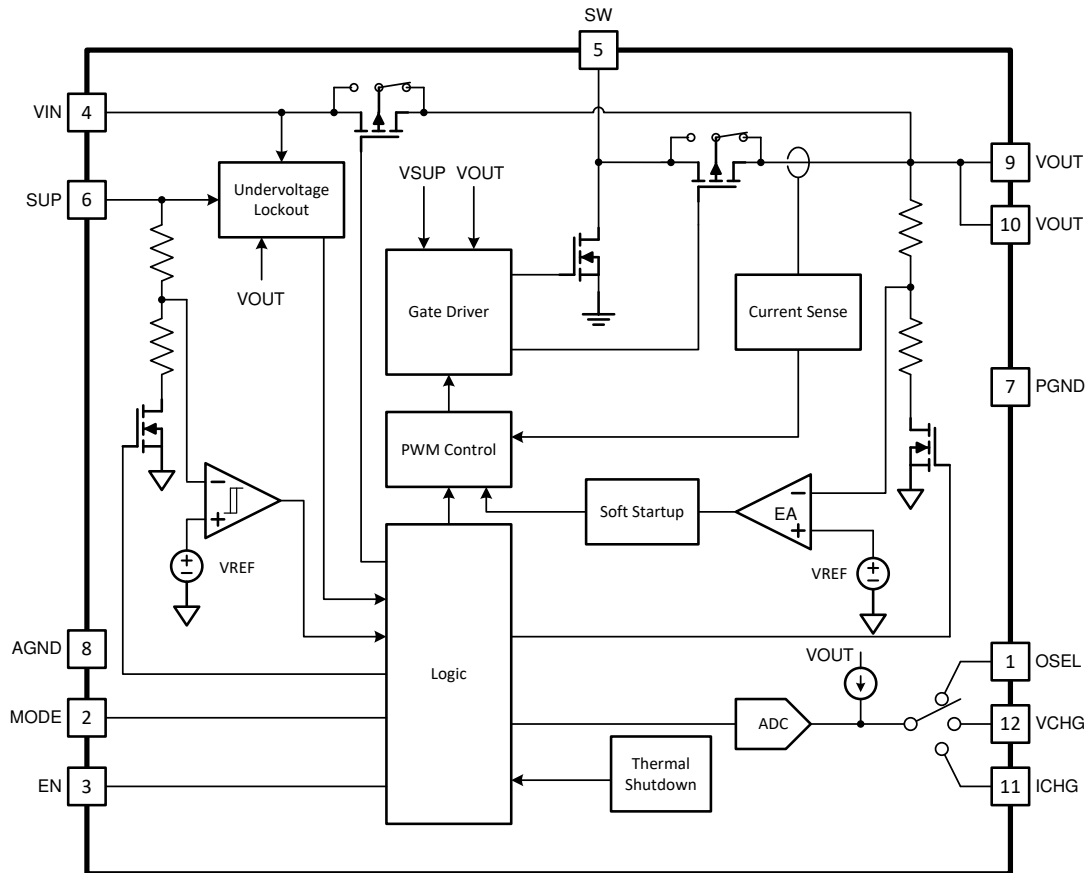
### 7.1.1.3 ICHG: Charging Output Current Selection

In Buck mode operation, the device supports sixteen internally-set charging currents by connecting a resistor between the ICHG pin and ground. [Table 7-3](#) lists the charging current options with respect to resistance.

**Table 7-3. Charging Current Options**

RESISTANCE (KΩ)	I <sub>CHG</sub> (MA)	RESISTANCE (KΩ)	I <sub>CHG</sub> (MA)	RESISTANCE (KΩ)	I <sub>CHG</sub> (MA)	RESISTANCE (KΩ)	I <sub>CHG</sub> (MA)
0	0 (disabled)	9.53	25	28.7	150	150	350
3.09	2.5	13.0	50	49.9	200	205	400
4.75	5	17.4	75	75.0	250	274	500
6.65	10	22.1	100	107	300	open	600

## 7.2 Functional Block Diagram



## 7.3 Feature Description

### 7.3.1 Undervoltage Lockout

The TPS61094 has a built-in undervoltage lockout (UVLO) circuit to make sure the device works properly. When the voltage at the VIN pin is above the undervoltage lockout (UVLO) rising threshold (typically 1.7 V), the TPS61094 can be enabled. After the TPS61094 starts up and the output voltage is above 1.7 V typically, the TPS61094 can work with SUP pin voltage as low as 0.6 V and input voltage down to 0 V. When the voltage at the VIN pin is down to 0 V and the voltage at the SUP pin are below the undervoltage lockout falling threshold (typically 0.6 V), the TPS61094 goes into Shutdown mode to avoid malfunction. In this condition and in Auto boost mode, the TPS61094 disconnects the bypass switch and high-side switch to prevent the reverse current from the VOUT pin to the VIN pin and SW pin when the V<sub>OUT</sub> voltage is above 1.6 V.

When the voltages at the VIN pin and SUP pin are below 1.7 V (typical) and the voltage at V<sub>OUT</sub> is below 1.6 V (typical), the TPS61094 goes into Shutdown mode.

### 7.3.2 Enable and Soft Start

When the voltage at the VIN pin is above the undervoltage lockout (UVLO) rising threshold (typically 1.7 V) and the EN pin is pulled to logic high voltage, the TPS61094 is enabled and starts ramping up the output voltage.

At Auto boost mode, the TPS61094 starts charging the output capacitor with a 300-mA constant current through the bypass switch when the output voltage is below 0.5 V. When the output voltages is charged above 0.5 V, the output current is changed to have output current capability to drive the 3.6-Ω resistance load until the output voltage reaches close to input voltage. After the output voltage reaches close to the input voltage, the TPS61094 starts to detect the configuration conditions of the VCHG, ICHG, and OSEL pins, then latches the configuration. According to the configurations and setup, the TPS61094 enters Boost mode or Buck mode. When input voltage is less than the output voltage setting, the TPS61094 enters Boost mode soft start. The

TPS61094 starts switching and output ramps up further. The soft-start time in Boost mode varies with the different output capacitance, load condition, and configuration conditions. When input voltage is higher than the output voltage setting adding 100 mV, the TPS61094 enters Buck mode soft start. The charging current can increase slowly.

The start-up of Forced buck mode is similar to Buck mode in Auto boost mode except the TPS61094 enters Buck mode after the output voltage is close to the input voltage and does not need to have the input voltage higher than the output voltage setting adding 100 mV.

At Forced bypass mode, there is no soft start. The bypass switch is always on and the output is connected to the input directly.

When the voltage at the EN pin is below 0.2 V and MODE is higher than 0.58 V at output voltage higher than 1.8 V, the internal enable comparator turns the device into True shutdown mode. In True shutdown mode, the device is entirely turned off. The output is disconnected from the VIN and SUP pin power supply.

### 7.3.3 Active Pulldown for the EN and MODE Pins

The EN and MODE pins have an active 800-kΩ pulldown resistor to ground. When the EN and MODE pins are logic high, there is high impedance to make sure there is no high leakage current in these pins. When the EN and MODE pins are logic low or floating, there is a 800-kΩ pulldown resistor to make sure the EN and MODE pins cannot be coupled to the logic high by the noise. TI suggests the pulling high capability be stronger than the 800-kΩ pulldown resistor when enabling the TPS61094.

### 7.3.4 Current Limit Operation

The TPS61094 has the peak current limit in Buck mode and valley current limit in Boost mode. Current limit detection occurs when the high-side MOSFET turns on.

In Buck mode, the TPS61094 has average output current control, so the current limit in Buck mode is hard to reach.

In Boost mode, when the load current is increased such that the inductor current is above the current limit within the whole switching cycle time, the off time is increased to allow the inductor current to decrease to this threshold before the next on time begins (called the frequency foldback mechanism). When the current limit is reached, the output voltage decreases during further load increase.

The maximum continuous output current ( $I_{OUT(LC)}$ ), before entering current limit (CL) operation, can be defined by [Equation 1](#).

$$I_{OUT(CL)} = (1-D) \times \left( I_{LIM} + \frac{1}{2} \Delta I_{L(P-P)} \right) \quad (1)$$

where

- D is the duty cycle.
- $\Delta I_{L(P-P)}$  is the inductor ripple current.

The duty cycle can be estimated by [Equation 2](#).

$$D = 1 - \frac{V_{IN} \times \eta}{V_{OUT}} \quad (2)$$

where

- $V_{OUT}$  is the output voltage of the boost converter.
- $V_{IN}$  is the input voltage of the boost converter.
- $\eta$  is the efficiency of the converter; use 90% for most applications.

The peak-to-peak inductor ripple current is calculated by [Equation 3](#).

$$\Delta I_{L(P-P)} = \frac{V_{IN} \times D}{L \times f_{SW}} \quad (3)$$

where

- L is the inductance value of the inductor.
- $f_{SW}$  is the switching frequency.
- D is the duty cycle.
- $V_{IN}$  is the input voltage of the boost converter.

### 7.3.5 Output Short-to-Ground Protection

The TPS61094 starts to limit the output current when the output voltage is below the minimum value ( $V_{IN}$ ,  $V_{OUT\_REG}$ ). The lower the output voltage reaches, the smaller the output current is. When the output voltage is below 0.5 V, the output current is limited to approximately 200 mA. Once the short circuit is released, the TPS61094 goes through the soft start-up again to output the regulated voltage.

### 7.3.6 Thermal Shutdown

The TPS61094 goes into thermal shutdown once the junction temperature exceeds 150°C. When the junction temperature drops below the thermal shutdown temperature threshold less the hysteresis, typically 130°C, the device starts operating again.

## 7.4 Device Functional Modes

### 7.4.1 Operation Mode Setting

The TPS61094 has four operation modes by the EN pin and MODE pin selection. [Table 7-4](#) lists the operation modes of the device with respect to the status of the EN and MODE pin.

**Table 7-4. Operation Modes**

MODES	EN	MODE	BYPASS	BOOST	BUCK	FUNCTION
Forced bypass	0	0	√	x	x	Turn on bypass MOSFET, turn off boost/buck, $V_{OUT} = V_{IN}$
True shutdown	0	1	x	x	x	Bypass disconnect, turn off boost/buck, $V_{OUT} = 0\text{ V}$
Forced buck	1	0	√	x	√	Buck enabled, turn on bypass MOSFET, $V_{OUT} = V_{IN}$ while charging the supercap or backup battery
Auto buck or boost	1	1	√	x	√	Buck enable, when $V_{IN} > \text{target } V_{OUT} + 100\text{ mV}$ and $V_{OUT} > \text{target } V_{OUT}$ , supercap is charged by buck
	1	1	√	√	x	Boost and bypass enabled; when $V_{OUT} + 100\text{ mV} > V_{IN} > \text{target } V_{OUT}$ and $V_{OUT} = \text{target } V_{OUT}$ , $V_{OUT}$ is from both $V_{IN}$ through bypass and supercap by boost.
	1	1	x	√	x	Boost enable; when $V_{IN} < \text{target } V_{OUT}$ , $V_{OUT}$ is powered from supercap by boost.

### 7.4.2 Forced Bypass Mode Operation

The TPS61094 works in Forced bypass mode when the voltage at the MODE and EN pins are logic low level (EN = low, MODE = low). In Forced bypass mode, the bypass switch is turned on, thus the voltage at the VOUT pin equals the input voltage. The TPS61094 has approximately 4-nA  $I_Q$  in Forced bypass mode. The TPS61094 does not detect input voltage and output voltage, so it cannot to protect the reverse current from output to input in Forced bypass mode.

### 7.4.3 True Shutdown Mode Operation

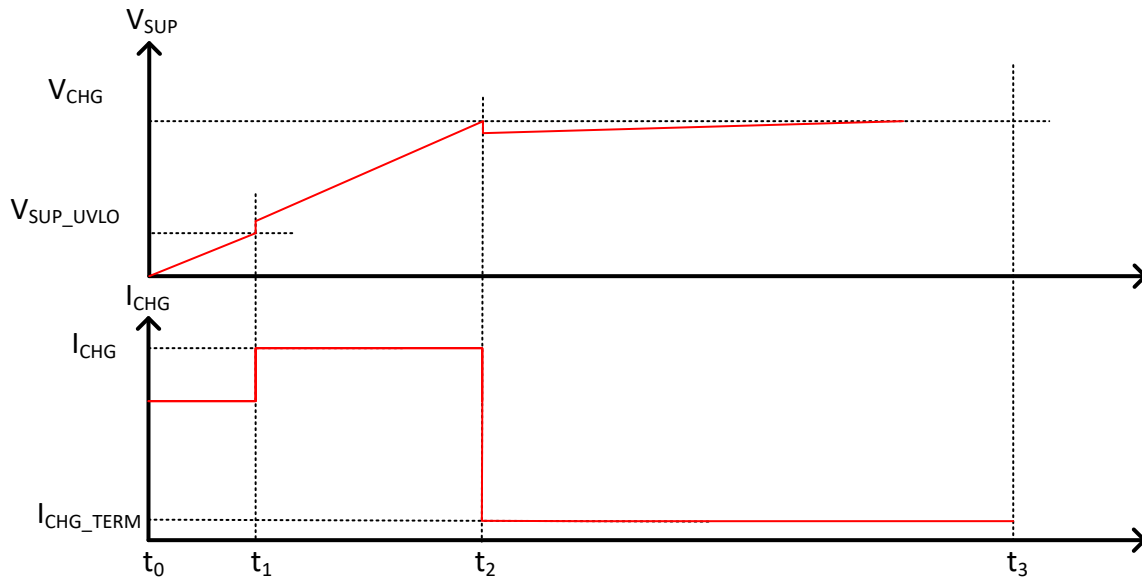
The TPS61094 works in True shutdown mode when the voltage at the MODE pin is logic high level and the voltage at the EN pin is logic low level (EN = low, MODE = high). In True shutdown mode, the TPS61094 is entirely turned off, the bypass MOSFET and high-side MOSFET are true shutdown, and the output is disconnected from the VIN pin and SUP pin power supply.

### 7.4.4 Forced Buck Mode Operation

When the TPS61094 is enabled working in Buck mode (EN = high, MODE = low), the TPS61094 works in constant output current control scheme with the bypass switch always turned on. The TPS61094 supports sixteen internally set options for the charging termination voltage (VCHG) and charging current (ICHG) by connecting a resistor between the VCHG pin, ICHG pin, and ground.

When  $V_{OUT}$  voltage is above the 1.7-V UVLO rising threshold, the buck function starts working to charge the supercap at the SUP pin. The typical charging operation ( $V_{CHG} < V_{IN} - 800\text{ mV}$ ) works as shown in [Figure 7-1](#). At  $t_0$ , the TPS61094 starts to charge the SUP pin by constant current. From  $t_0$  to  $t_1$ , when the SUP pin voltage is lower than  $V_{SUP\_UVLO}$ , typically 0.85 V, the TPS61094 charges the SUP pin by the constant current (ICHG\_PRE), which is smaller than or equal to 250 mA. From  $t_1$  to  $t_2$ , when the SUP pin voltage reaches  $V_{SUP\_UVLO}$ , the TPS61094 charges the SUP pin by constant current (ICHG), which is set by the ICHG pin. At  $t_2$ , the SUP pin voltage reaches VCHG (charging termination voltage) and the TPS61094 reduces the charging current to ICHG\_TERM, the device stops switching until the SUP voltage reaches VCHG without the supercap ESR voltage drop. This can be avoided if the supercap is not fully charged when the SUP pin reaches VCHG in high charging current because of supercap ESR voltage drop. The TPS61094 starts switching when the SUP voltage drops 75 mV below the target value (VCHG).

If  $V_{CHG} > V_{IN} - 500\text{ mV}$ , the TPS61094 will decrease the charging current when the SUP pin voltage is close to VIN.



**Figure 7-1. Typical Charging Operation**

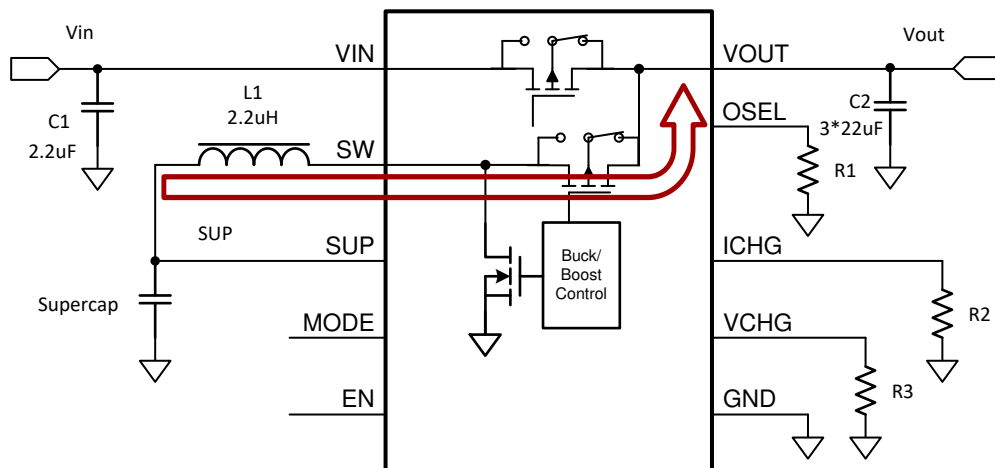
1. ICHG\_PRE is 250 mA when ICHG is equal or larger than 250 mA; ICHG\_PRE is ICHG when ICHG is lower than 250 mA.
2. ICHG\_TERM is 10 mA when ICHG is equal or larger than 10 mA; ICHG\_TERM is 2.5 mA when ICHG is lower than 10 mA.

#### 7.4.5 Auto Buck or Boost Mode Operation

The TPS61094 is enabled working in Auto buck or Boost mode at EN = high and MODE = high.

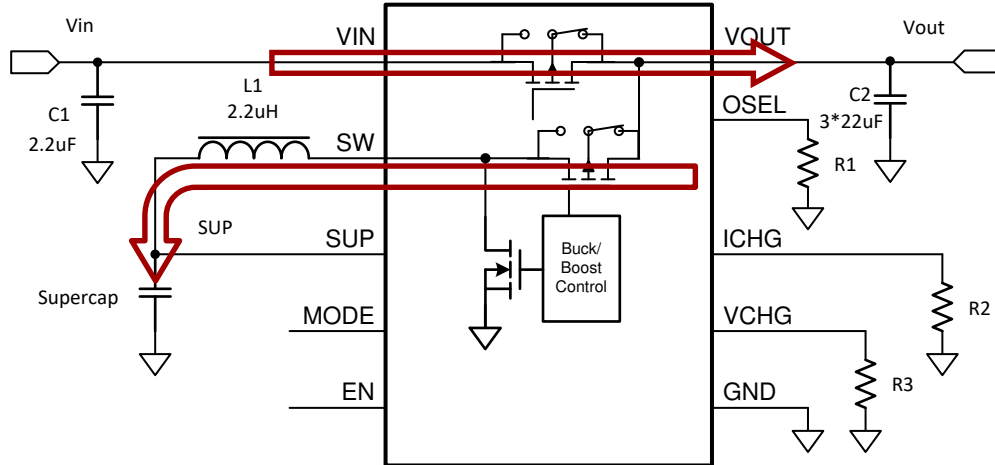
##### 7.4.5.1 Three States (Boost\_on, Buck\_on, and Supplement) Transition

In Auto buck or Boost mode operation, there are three states: boost\_on, buck\_on, and supplement, as shown in Figure 7-2 to Figure 7-4. The boost\_on state occurs when the bypass switch is turned off and the TPS61094 works in Boost mode to regulate output voltage to the OSEL setting. The buck\_on state occurs when the bypass switch is turned on and the TPS61094 works in Buck mode, charging the SUP pin by an input source according to the charging current and termination voltage settings at the ICHG and VCHG pin in this situation, which is similar to the Forced buck mode operation. Supplement mode is the intermediate state when the TPS61094 transfers between boost\_on and buck\_on operation. In Supplement mode, Boost mode is active and the bypass MOSFET operates as an LDO, the VIN and SUP power source supply the output load together.

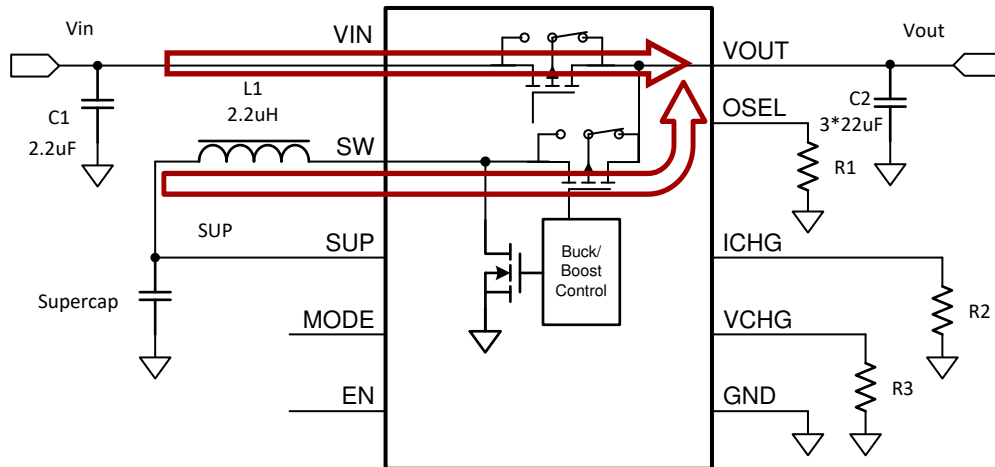


**Figure 7-2. Typical Boost\_on State Circuit**



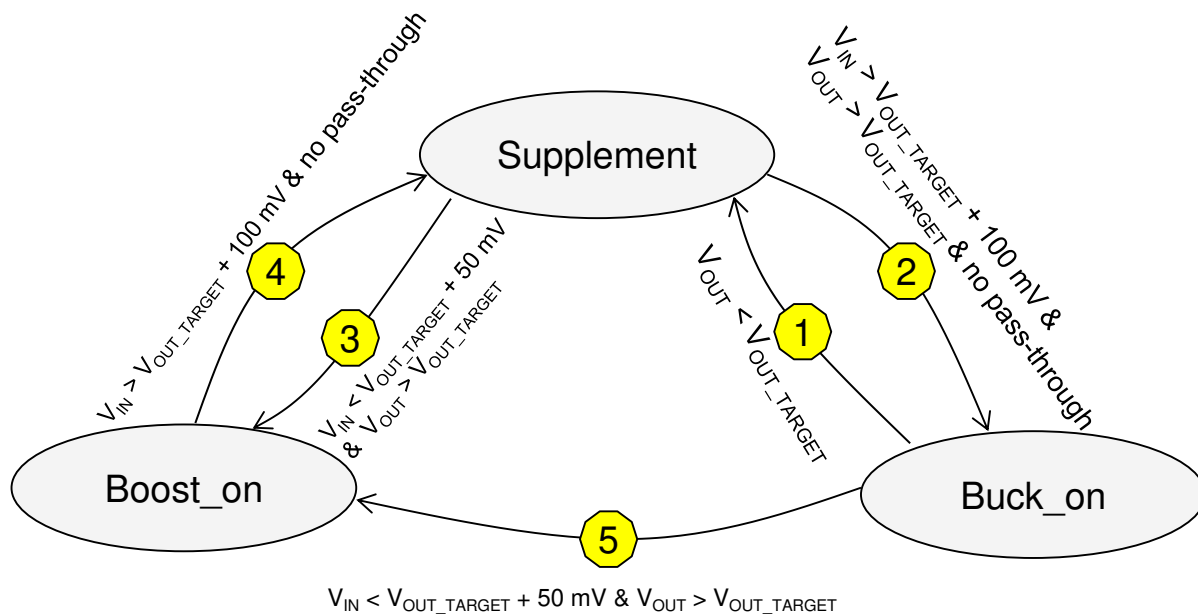


**Figure 7-3. Typical Buck\_on State Circuit**



**Figure 7-4. Typical Supplement State Circuit**

The TPS61094 can automatically transfer in these three states based on input voltage and output voltage, as shown in [Figure 7-5](#).



**Figure 7-5. Three States(Boost\_on, Buck\_on, and Supplement) Transition**

Path 1: The TPS61094 works at buck\_on state first. There is a heavy load transient in the output load and the input source cannot hold it, which makes the output voltage lower than the output target voltage (OSEL pin setting). The TPS61094 transfers from buck\_on to supplement state. Input and SUP power source can supply the heavy load together.

Path 2: In supplement state, if the input voltage is higher than the output target voltage + 100 mV and the output voltage is higher than the output target voltage, meaning the input power source can support the output load, the TPS61094 transfers from supplement to buck\_on state.

Path 3: In supplement operation, if the output load is light, the output voltage is higher than the output target voltage. The TPS61094 transfers from supplement to boost\_on state. The TPS61094 has approximately 60-nA  $I_Q$  in Boost mode, which can help the system has higher efficiency at light load.

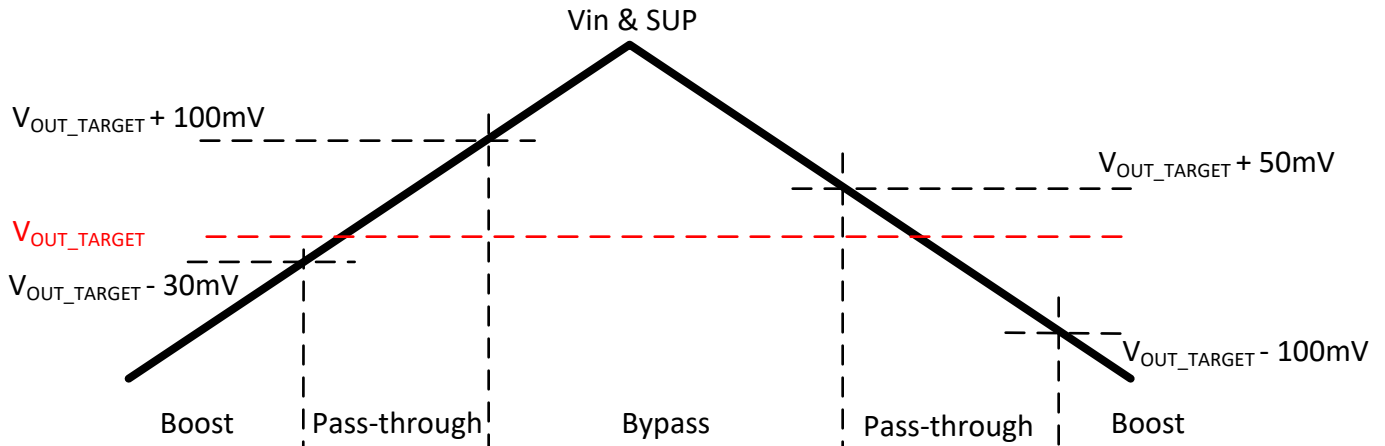
Path 4: In boost\_on state, when the input power source is higher than the output target voltage + 100 mV, the TPS61094 transfers from boost\_on to supplement state.

Path 5: A quick way to transfer from buck\_on to boost\_on state. At buck\_on state, if the load is light and input voltage is lower than the output target voltage + 100 mV, the TPS61094 can enter boost\_on state.

In boost\_on mode, when the SUP pin voltage is higher than output target voltage, the TPS61094 enters Pass-through mode. The TPS61094 stops switching and fully turns on high-side MOSFET. The devices stays in boost\_on (Pass-through mode) until the SUP pin voltage is lower than the output target voltage.

#### 7.4.5.2 Boost, Bypass, and Pass-Through

When the voltage at the VIN pin is below the boost regulation voltage, the bypass switch is turned off. The TPS61094 works in Boost mode to regulate the output voltage. When the voltage at the VIN pin is 0.1 V above the boost regulation voltage, the boost operation stops and the bypass switch is turned on. To make the transfer between Boost mode and Bypass mode smooth, there is a Pass-through mode when the input voltage is close to the target output voltage, as shown in Figure 7-6. The quiescent current at pass through mode is much higher than boost mode and bypass mode because the TPS61094 can detect the high-side MOS current.



**Figure 7-6. Typical Supplement Operation Circuit**

#### 7.4.5.3 PWM, PFM, and Snooze Modes in Boost Operation

The TPS61094 has three switching operation modes in boost operation: PWM mode in moderate-to-heavy load conditions, pulse frequency modulation (PFM) in light load conditions, and Snooze mode in ultra-low load.

##### 7.4.5.3.1 PWM Mode

The TPS61094 uses a quasi-constant 1.0-MHz frequency pulse width modulation (PWM) at moderate-to-heavy load current. Based on the input-to-output voltage ratio, a circuit predicts the required on time. At the beginning of the switching cycle, the low-side FET turns on. The input voltage is applied across the inductor and the inductor current ramps up. In this phase, the output capacitor is discharged by the load current. When the on time expires, the low-side FET is turned off and the high-side FET is turned on. The inductor transfers its stored energy to replenish the output capacitor and supply the load. The inductor current declines because the output voltage is higher than the input voltage. When the inductor current hits the valley current threshold determined by the output of the error amplifier, the next switching cycle starts again.

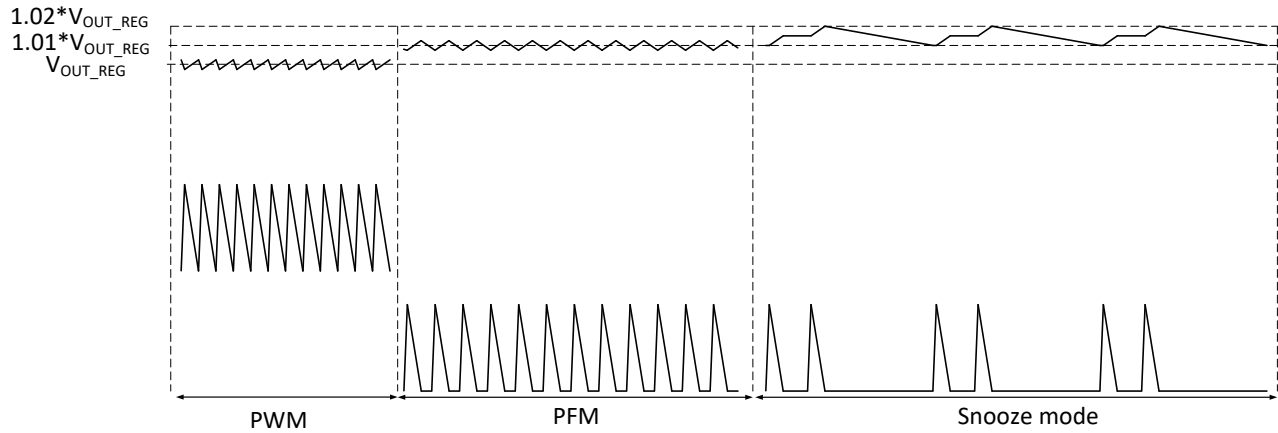
The TPS61094 has a built-in compensation circuit that can accommodate a wide range of input voltage, output voltage, inductor value, and output capacitor value for stable operation.

##### 7.4.5.3.2 PFM Mode

The TPS61094 integrates the one-pulse PFM to improve efficiency and decrease output ripple at light load. When the load current decreases, the inductor valley current setting by the output of the error amplifier no longer regulates the output voltage. When the inductor valley current hits the low limit, the output voltage exceeds the setting voltage as the load current decreases further. The TPS61094 goes into PFM mode. In PFM mode, the off time is extended by decreasing load and the TPS61094 regulates output voltage to the PFM reference voltage (typically  $101\% \times V_{OUT\_REG}$ ). The PFM operation reduces the switching losses and improves efficiency at light load condition by reducing the average switching frequency.

##### 7.4.5.3.3 Snooze Mode

The TPS61094 integrates Snooze mode to decrease quiescent current. If the load current is reduced further, the boost converter enters into Snooze mode. In Snooze mode, the boost converter ramps up the output voltage with several switching cycles. Once the output voltage exceeds a setting threshold, the device stops switching and goes into a sleep status. In sleep status, the device consumes less quiescent current. It resumes switching when the output voltage is below the setting threshold. It exits Burst mode when the output current can no longer be supported in this mode. Refer to [Figure 7-7](#) for Burst mode operation details.



**Figure 7-7. Boost Mode Operation**

## 8 Application and Implementation

### Note

Information in the following applications sections is not part of the TI component specification, and TI does not warrant its accuracy or completeness. TI's customers are responsible for determining suitability of components for their purposes, as well as validating and testing their design implementation to confirm system functionality.

### 8.1 Application Information

The TPS61094 is a 60-nA quiescent current synchronous bi-directional buck/boost converter with a bypass switch between the input and output. The TPS61094 can operate with a wide input voltage from 0.7 V to 5.5 V and output voltage from 1.8 V to 5.5 V. The device provides an ultra-low power solution optimized for applications that require ultra-low quiescent current, use a supercap or battery as backup power supply, or both. The TPS61094 has two typical application circuits. One is the pure boost with bypass function, as shown in Figure 8-1, which connects the SUP pin and VIN pin together. The other is the supercap backup application, which separates the SUP pin and VIN pin, as shown in Figure 8-14, which can charge supercap or boost supercap to power the output.

### 8.2 Typical Application – 3.6-V Output Boost Converter with Bypass

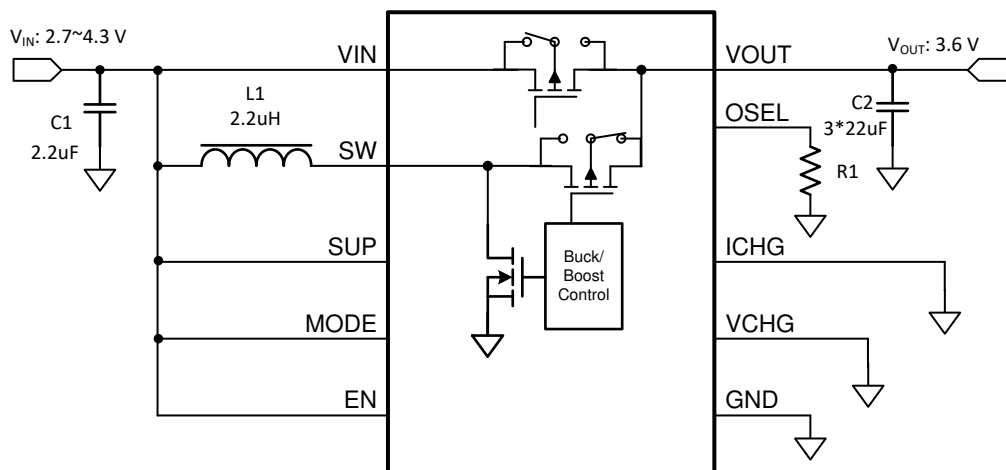


Figure 8-1. Li-ion Battery to 3.6-V Boost Converter with Bypass

#### 8.2.1 Design Requirements

The design parameters are listed in Table 8-1.

Table 8-1. Design Requirements

PARAMETERS	VALUES
Input Voltage	2.7 V ~ 4.3 V
Output Voltage	3.6 V
Output Current	500 mA
Output Voltage Ripple	± 50 mV

#### 8.2.2 Detailed Design Procedure

##### 8.2.2.1 Programming the Output Voltage

The output voltage is set by the resistor between the OSEL pin and ground. Take Table 7-1 as reference,  $R_1 = 17.4 \text{ k}\Omega$  for  $V_{OUT} = 3.6 \text{ V}$ . For proper operation, the resistance accuracy must be 1%. TI suggests to short the VCHG pin and ICHG pin to ground at the pure boost with bypass application.

### 8.2.2.2 Maximum Output Current

The maximum output capability of the TPS61094 is determined by the input-to-output ratio and the current limit of the boost converter. It can be estimated by [Equation 4](#).

$$I_{OUT(max)} = \frac{V_{IN} \cdot (I_{LIM} - \frac{I_{LH}}{2}) \cdot \eta}{V_{OUT}} \quad (4)$$

where

- $\eta$  is the conversion efficiency, use 85% for estimation.
- $I_{LH}$  is the current ripple value.
- $I_{LIM}$  is the switch current limit.

Minimum input voltage, maximum boost output voltage, and minimum current limit  $I_{LIM}$  should be used as the worst case condition for the estimation.

### 8.2.2.3 Inductor Selection

Because the selection of the inductor affects steady-state operation, transient behavior, and loop stability, the inductor is the most important component in power regulator design. There are three important inductor specifications: inductor value, saturation current, and DC resistance (DCR).

The TPS61094 is designed to work with 1- $\mu$ H or 2.2- $\mu$ H inductor values. Follow [Equation 5](#) to [Equation 7](#) to calculate the inductor peak current for the application. To calculate the current in the worst case, use the minimum input voltage, maximum output voltage, and maximum load current of the application. To have enough design margins, choose the inductor value with –30% tolerances and low power-conversion efficiency for the calculation.

In a boost regulator, the inductor DC current can be calculated by [Equation 5](#).

$$I_{L(DC)} = \frac{V_{OUT} \times I_{OUT}}{V_{IN} \times \eta} \quad (5)$$

where

- $V_{OUT}$  is the output voltage of the boost converter.
- $I_{OUT}$  is the output current of the boost converter.
- $V_{IN}$  is the input voltage of the boost converter.
- $\eta$  is the power conversion efficiency, use 90% for most applications.

The inductor ripple current is calculated by [Equation 6](#).

$$\Delta I_{L(P-P)} = \frac{V_{IN} \times D}{L \times f_{SW}} \quad (6)$$

where

- $D$  is the duty cycle, which can be calculated by [Equation 2](#).
- $L$  is the inductance value of the inductor.
- $f_{SW}$  is the switching frequency.
- $V_{IN}$  is the input voltage of the boost converter.

Therefore, the inductor peak current is calculated by [Equation 7](#).

$$I_{L(P)} = I_{L(DC)} + \frac{\Delta I_{L(P-P)}}{2} \quad (7)$$

Normally, it is advisable to work with an inductor peak-to-peak current of less than 40% of the average inductor current for maximum output current. A smaller ripple from a larger-valued inductor reduces the magnetic hysteresis losses in the inductor and EMI, but in the same way, load transient response time is increased. The saturation current of the inductor must be higher than the calculated peak inductor current. [Table 8-2](#) lists the recommended inductors for the TPS61094.

**Table 8-2. Recommended Inductors for the TPS61094**

PART NUMBER	L (μH)	DCR MAX (mΩ)	SATURATION CURRENT (A)	SIZE (LxWxH)	VENDOR <sup>(1)</sup>
XGL4020-222ME	2.2	21.5	4.4	4.0 × 4.0 × 2.1	Coilcraft
VCHA042A-2R2MS6	2.2	23.0	4.5	4.3 × 4.3 × 2.1	Cyntec
744383560 22	2.2	35.0	6.2	4.1 × 4.1 × 2.1	Würth Elektronik

(1) See the [Third-Party Products](#) disclaimer

### 8.2.2.4 Output Capacitor Selection

The output capacitor is mainly selected to meet the requirements for output ripple and loop stability. The ripple voltage is related to capacitor capacitance and its equivalent series resistance (ESR). Assuming a ceramic capacitor with zero ESR, the minimum capacitance needed for a given ripple voltage can be calculated by [Equation 8](#).

$$C_{OUT} = \frac{I_{OUT} \times D_{MAX}}{f_{SW} \times V_{RIPPLE}} \quad (8)$$

where

- $D_{MAX}$  is the maximum switching duty cycle.
- $V_{RIPPLE}$  is the peak-to-peak output ripple voltage.
- $I_{OUT}$  is the maximum output current.
- $f_{SW}$  is the switching frequency.

The ESR impact on the output ripple must be considered if tantalum or aluminum electrolytic capacitors are used. The output peak-to-peak ripple voltage caused by the ESR of the output capacitors can be calculated by [Equation 9](#).

$$V_{RIPPLE(ESR)} = I_{L(P)} \times R_{ESR} \quad (9)$$

Take care when evaluating the derating of a ceramic capacitor under DC bias voltage, aging, and AC signal. For example, the DC bias voltage can significantly reduce capacitance. A ceramic capacitor can lose more than 50% of its capacitance at its rated voltage. Therefore, always leave margin on the voltage rating to make sure there is adequate capacitance at the required output voltage. Increasing the output capacitor makes the output ripple voltage smaller in PWM mode.

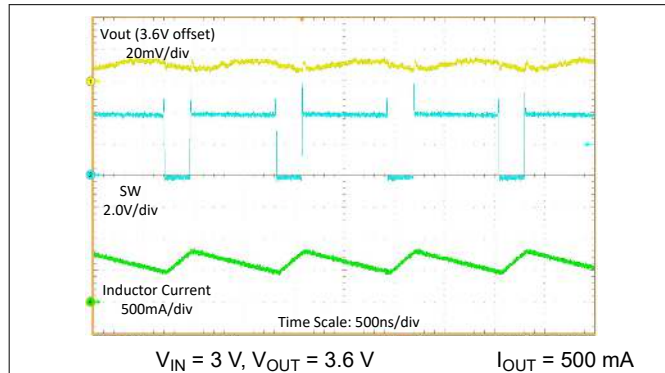
TI recommends using the X5R or X7R ceramic output capacitor in the range of 4-μF to 1000-μF effective capacitance. The output capacitor affects the small signal control loop stability of the boost regulator. If the output capacitor is below the range, the boost regulator can potentially become unstable. Increasing the output capacitor makes the output ripple voltage smaller in PWM mode.

### 8.2.2.5 Input Capacitor Selection

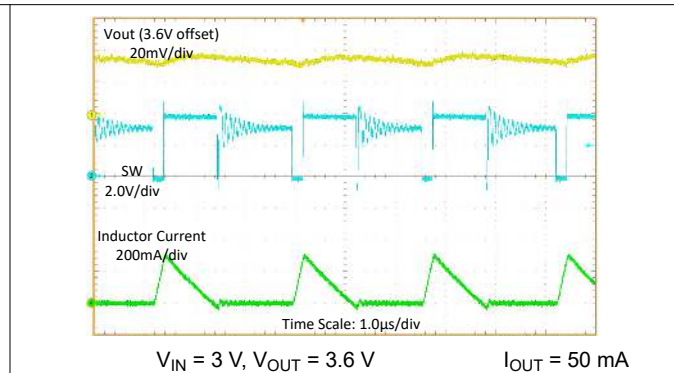
Multilayer X5R or X7R ceramic capacitors are excellent choices for the input decoupling of the step-up converter as they have extremely low ESR and are available in small footprints. Input capacitors must be located as close as possible to the device. While a 10-μF input capacitor is sufficient for most applications, larger values can be used to reduce input current ripple without limitations. Take care when using only ceramic input capacitors. When a ceramic capacitor is used at the input and the power is being supplied through long wires, a load step at the output can induce ringing at the VIN pin. This ringing can couple to the output and be mistaken as loop instability or can even damage the part. In this circumstance, place additional bulk capacitance (tantalum or

aluminum electrolytic capacitor) between ceramic input capacitor and the power source to reduce ringing that can occur between the inductance of the power source leads and ceramic input capacitor.

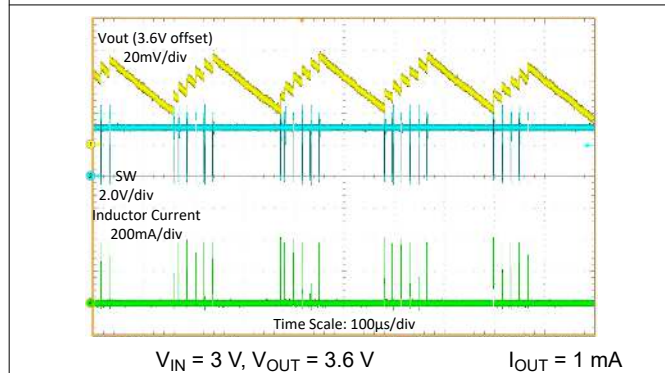
### 8.2.3 Application Curves



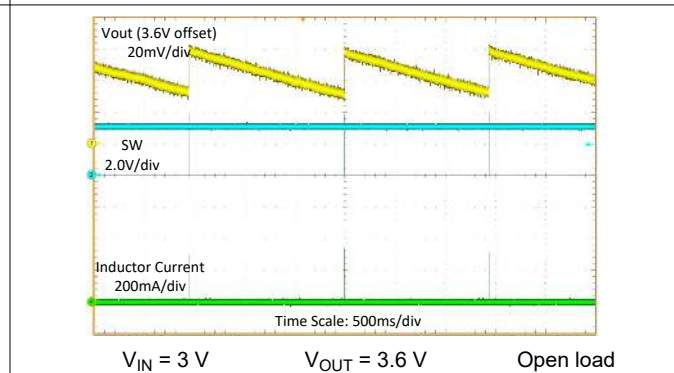
**Figure 8-2. Switching Waveform at Heavy Load**



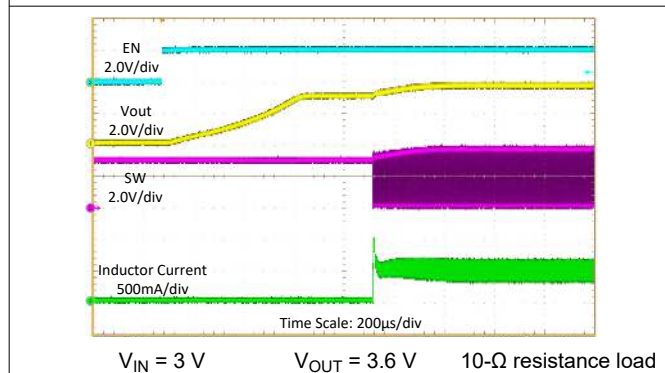
**Figure 8-3. Switching Waveform at Medium Load**



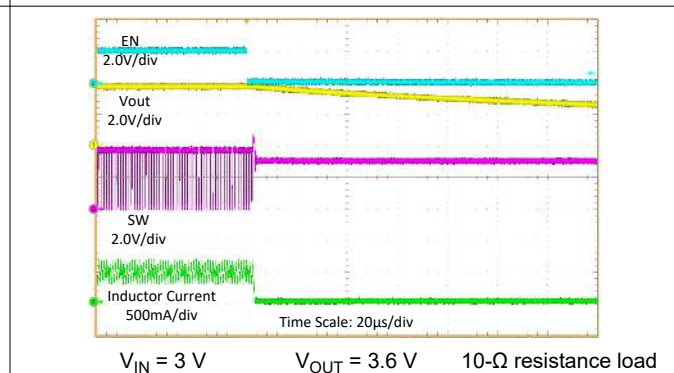
**Figure 8-4. Switching Waveform at Light Load**



**Figure 8-5. Switching Waveform at Open Load**

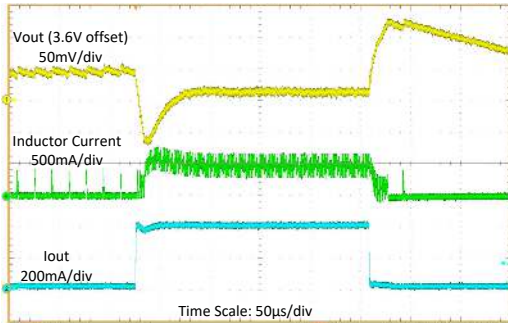


**Figure 8-6. Start-Up Waveform**



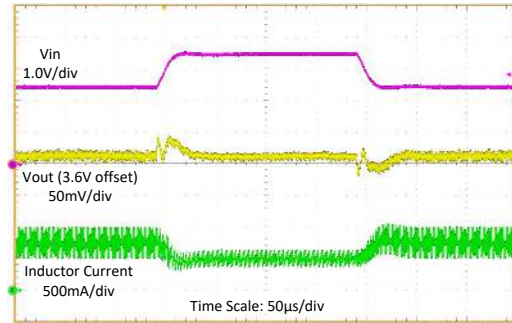
**Figure 8-7. Shutdown Waveform**





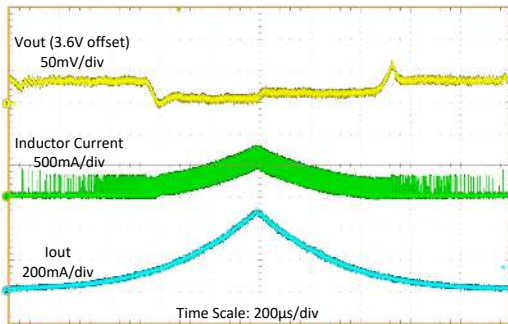
$V_{IN} = 3\text{ V}$                        $V_{OUT} = 3.6\text{ V}$   
 $I_{OUT} = 10\text{ mA to } 400\text{ mA with } 20\text{-}\mu\text{s slew rate}$

**Figure 8-8. Load Transient at Boost Mode**



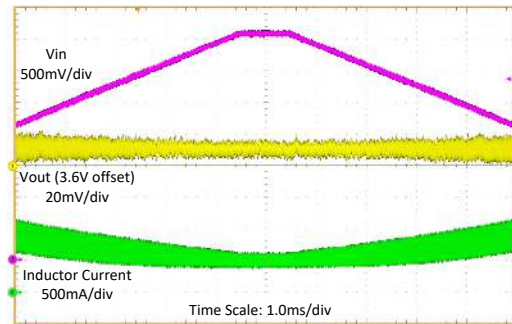
$V_{OUT} = 3.6\text{ V}$                        $I_{OUT} = 500\text{ mA}$   
 $V_{IN} = 2.5\text{ V to } 3.5\text{ V with } 20\text{-}\mu\text{s slew rate}$

**Figure 8-9. Line Transient**



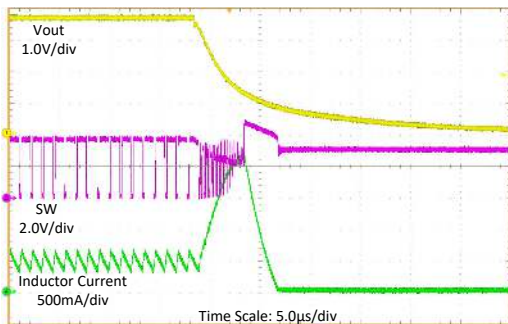
$V_{IN} = 3\text{ V}$                        $V_{OUT} = 3.6\text{ V}$   
 $I_{OUT} = 0\text{-A to } 500\text{-mA Sweep}$

**Figure 8-10. Load Sweep**



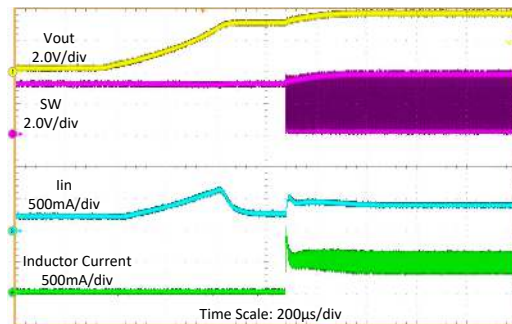
$V_{OUT} = 3.6\text{ V}$                        $10\text{-}\Omega$  resistance load  
 $V_{IN} = 2.0\text{-V to } 3.5\text{-V Sweep}$

**Figure 8-11. Line Sweep**



$V_{IN} = 3\text{ V}$                        $V_{OUT} = 3.6\text{ V}$   
 $10\text{-}\Omega$  resistance load

**Figure 8-12. Output Short Protection (Entry)**



$V_{IN} = 3\text{ V}$                        $V_{OUT} = 3.6\text{ V}$   
 $10\text{-}\Omega$  resistance load

**Figure 8-13. Output Short Protection (Recover)**

### 8.2.4 Typical Application – 3.3-V Output Boost Converter with Automatic Buck or Boost Function

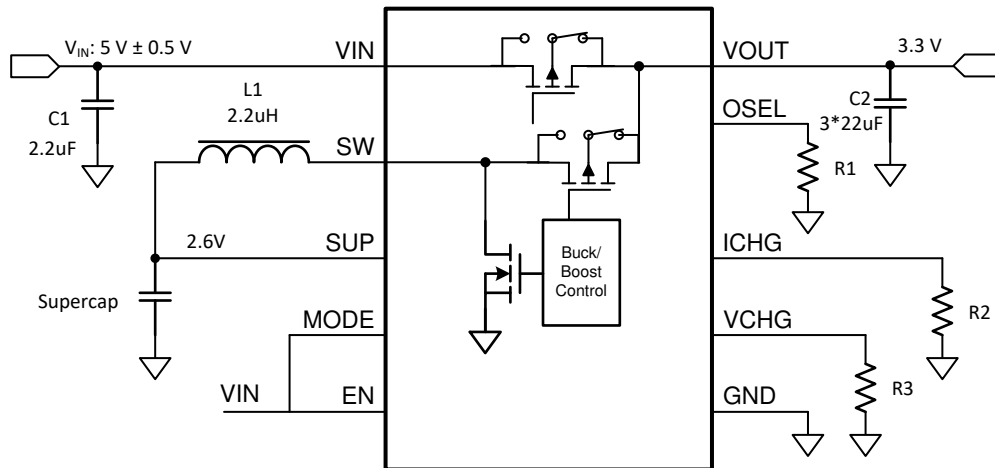


Figure 8-14. 5-V Input Source to 3.3-V Boost Converter with Automatic Buck or Boost Function

#### 8.2.4.1 Design Requirements

The design parameters are listed in [Table 8-3](#).

Table 8-3. Design Requirements

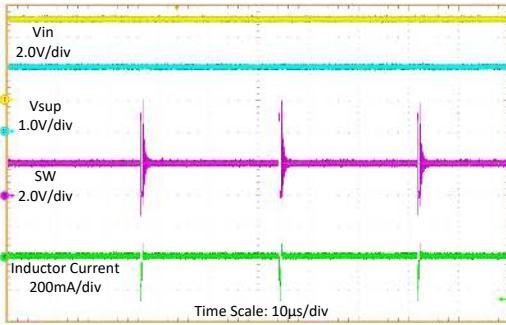
PARAMETERS	VALUES
Input Voltage	5 V ± 0.5 V
Output Voltage	3.3 V
Output Current	250 mA
Output Voltage Ripple	± 50 mV
Supercap Charging Termination Voltage	2.6 V
Supercap Charging Current	100 mA

#### 8.2.4.2 Detailed Design Procedure

##### 8.2.4.2.1 Programming the Voltage and Current

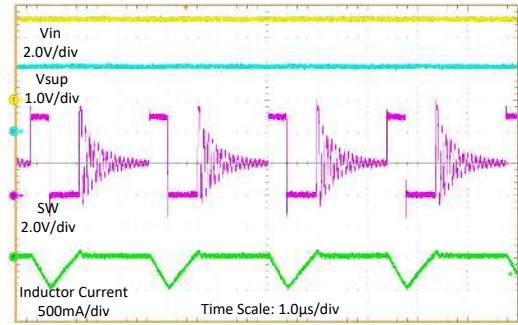
The output voltage is set by the resistor between the OSEL pin and ground. Take as reference  $R_1 = 4.75 \text{ k}\Omega$  for  $V_{OUT} = 3.3 \text{ V}$ . The charging termination voltage is set by the resistor between the VCHG pin and ground. Take as reference  $R_1 = 9.53 \text{ k}\Omega$  for  $V_{CHG\_REG} = 2.6 \text{ V}$ . The charging current is set by the resistor between the ICHG pin and ground. Take as reference  $R_1 = 22.1 \text{ k}\Omega$  for  $I_{CHG\_REG} = 100 \text{ mA}$ . For proper operation, the resistance accuracy must be 1%.

### 8.2.4.3 Application Curves



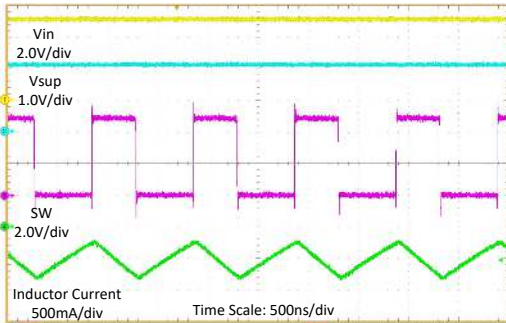
$V_{IN} = 5\text{ V}$        $V_{SUP} = 2\text{ V}$

**Figure 8-15. Switching Waveform at Buck Mode with  $I_{CHG} = 2.5\text{ mA}$**



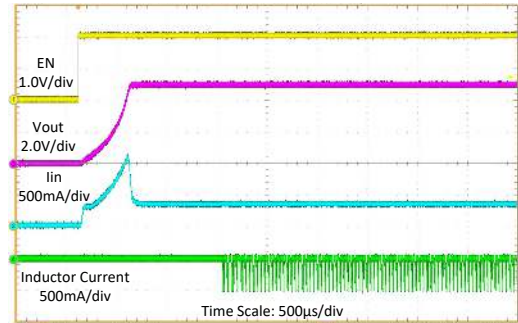
$V_{IN} = 5\text{ V}$        $V_{SUP} = 2\text{ V}$

**Figure 8-16. Switching Waveform at Buck Mode with  $I_{CHG} = 100\text{ mA}$**



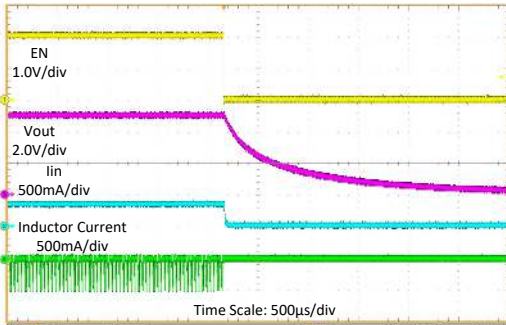
$V_{IN} = 5\text{ V}$        $V_{SUP} = 2\text{ V}$

**Figure 8-17. Switching Waveform at Buck Mode with  $I_{CHG} = 500\text{ mA}$**



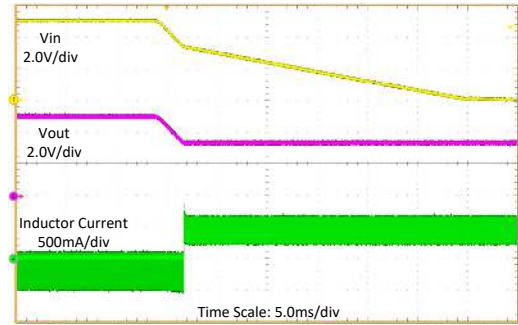
$V_{IN} = 5\text{ V}$        $V_{SUP} = 0\text{ V}$        $R_{LOAD} = 15\ \Omega$

**Figure 8-18. Start-Up by EN**



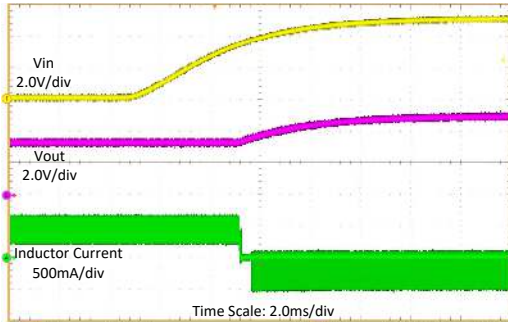
$V_{IN} = 5\text{ V}$        $V_{SUP} = 0\text{ V}$        $R_{LOAD} = 15\ \Omega$

**Figure 8-19. Shutdown by EN**

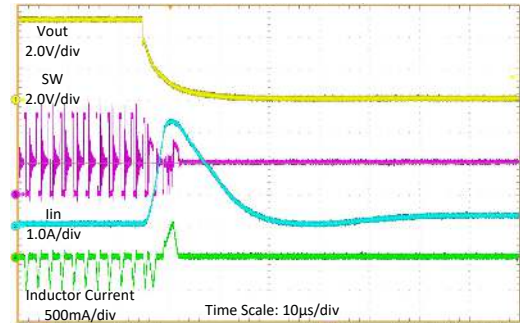


$V_{IN} = 5\text{ V}$        $V_{SUP} = 2\text{ V}$        $I_{OUT} = 250\text{ mA}$

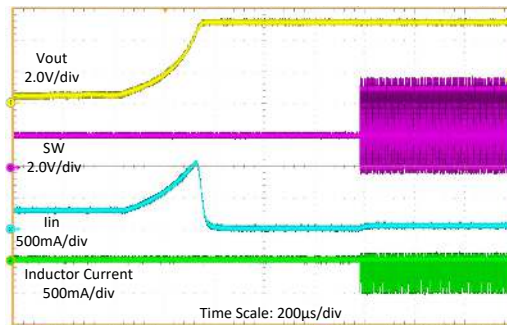
**Figure 8-20.  $V_{IN}$  Power Down and Backup Automatically**



**Figure 8-21.  $V_{IN}$  Power On and Charging Automatically**



**Figure 8-22. Output Short Protection (Entry)**



**Figure 8-23. Output Short Protection (Recover)**

## 9 Power Supply Recommendations

The device is designed to operate from an input voltage supply range between 0.7 V to 5.5 V. This input supply must be well regulated. If the input supply is located more than a few inches from the converter, additional bulk capacitance can be required in addition to the ceramic bypass capacitors. A typical choice is a tantalum or aluminum electrolytic capacitor with a value of 100  $\mu\text{F}$ . Output current of the input power supply must be rated according to the supply voltage, output voltage, and output current of the TPS61094.

## 10 Layout

### 10.1 Layout Guidelines

As for all switching power supplies, the layout is an important step in the design, especially at high peak currents and high switching frequencies. If the layout is not carefully done, the regulator can show stability problems as well as EMI problems. Therefore, use wide and short traces for the main current path and for the power ground paths. The input and output capacitor, as well as the inductor should be placed as close as possible to the IC.

### 10.2 Layout Example

The bottom layer is a large GND plane connected by vias.

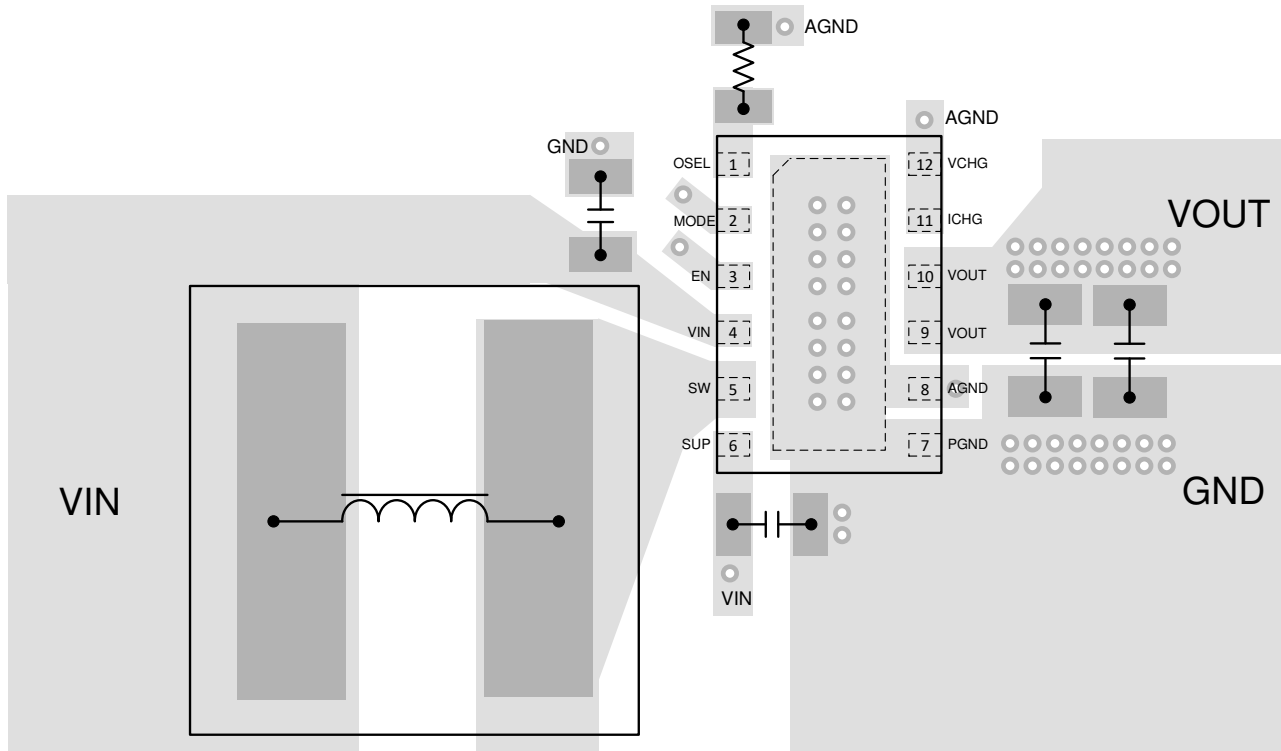
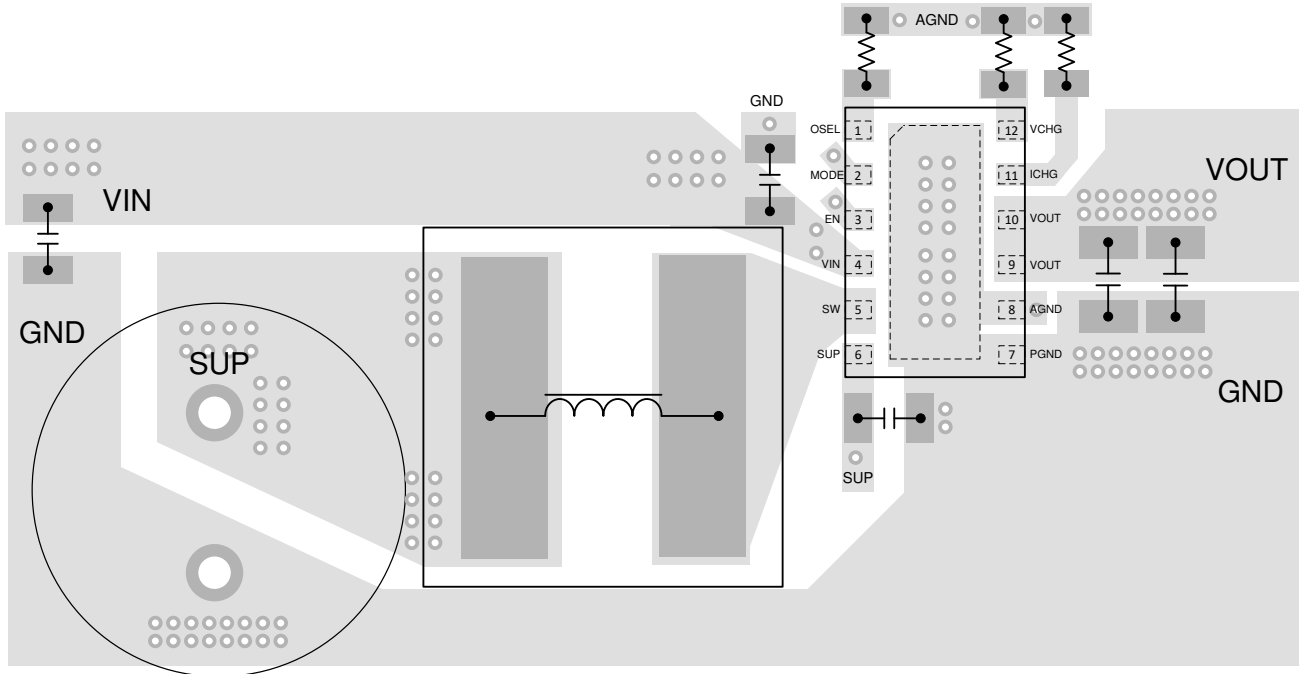


Figure 10-1. Layout: Boost Converter with Bypass Mode



**Figure 10-2. Layout: Boost Converter with Automatic Bypass and Buck function**

## 11 Device and Documentation Support

### 11.1 Device Support

#### 11.1.1 Third-Party Products Disclaimer

TI'S PUBLICATION OF INFORMATION REGARDING THIRD-PARTY PRODUCTS OR SERVICES DOES NOT CONSTITUTE AN ENDORSEMENT REGARDING THE SUITABILITY OF SUCH PRODUCTS OR SERVICES OR A WARRANTY, REPRESENTATION OR ENDORSEMENT OF SUCH PRODUCTS OR SERVICES, EITHER ALONE OR IN COMBINATION WITH ANY TI PRODUCT OR SERVICE.

### 11.2 Documentation Support

#### 11.2.1 Related Documentation

For related documentation see the following:

- Texas Instruments, [Performing Accurate PFM Mode Efficiency Measurements Application Report](#)
- Texas Instruments, [Accurately Measuring Efficiency of Ultra-low-IQ Devices Technical Brief](#)
- Texas Instruments, [IQ: What it is, What it isn't, and How to Use it Technical Brief](#)

### 11.3 Receiving Notification of Documentation Updates

To receive notification of documentation updates, navigate to the device product folder on [ti.com](#). Click on *Subscribe to updates* to register and receive a weekly digest of any product information that has changed. For change details, review the revision history included in any revised document.

### 11.4 Support Resources

[TI E2E™ support forums](#) are an engineer's go-to source for fast, verified answers and design help — straight from the experts. Search existing answers or ask your own question to get the quick design help you need.

Linked content is provided "AS IS" by the respective contributors. They do not constitute TI specifications and do not necessarily reflect TI's views; see TI's [Terms of Use](#).

### 11.5 Trademarks

TI E2E™ is a trademark of Texas Instruments.

All trademarks are the property of their respective owners.

### 11.6 Electrostatic Discharge Caution



This integrated circuit can be damaged by ESD. Texas Instruments recommends that all integrated circuits be handled with appropriate precautions. Failure to observe proper handling and installation procedures can cause damage.

ESD damage can range from subtle performance degradation to complete device failure. Precision integrated circuits may be more susceptible to damage because very small parametric changes could cause the device not to meet its published specifications.

### 11.7 Glossary

[TI Glossary](#) This glossary lists and explains terms, acronyms, and definitions.



## 12 Mechanical, Packaging, and Orderable Information

The following pages include mechanical packaging and orderable information. This information is the most current data available for the designated devices. This data is subject to change without notice and revision of this document. For browser-based versions of this data sheet, refer to the left-hand navigation.

**PACKAGING INFORMATION**

Orderable Device	Status (1)	Package Type	Package Drawing	Pins	Package Qty	Eco Plan (2)	Lead finish/ Ball material (6)	MSL Peak Temp (3)	Op Temp (°C)	Device Marking (4/5)	Samples
TPS61094DSSR	ACTIVE	WSON	DSS	12	3000	RoHS & Green	NIPDAU	Level-1-260C-UNLIM	-40 to 125	S61094	Samples

(1) The marketing status values are defined as follows:

**ACTIVE:** Product device recommended for new designs.

**LIFEBUY:** TI has announced that the device will be discontinued, and a lifetime-buy period is in effect.

**NRND:** Not recommended for new designs. Device is in production to support existing customers, but TI does not recommend using this part in a new design.

**PREVIEW:** Device has been announced but is not in production. Samples may or may not be available.

**OBSOLETE:** TI has discontinued the production of the device.

(2) **RoHS:** TI defines "RoHS" to mean semiconductor products that are compliant with the current EU RoHS requirements for all 10 RoHS substances, including the requirement that RoHS substance do not exceed 0.1% by weight in homogeneous materials. Where designed to be soldered at high temperatures, "RoHS" products are suitable for use in specified lead-free processes. TI may reference these types of products as "Pb-Free".

**RoHS Exempt:** TI defines "RoHS Exempt" to mean products that contain lead but are compliant with EU RoHS pursuant to a specific EU RoHS exemption.

**Green:** TI defines "Green" to mean the content of Chlorine (Cl) and Bromine (Br) based flame retardants meet JS709B low halogen requirements of <=1000ppm threshold. Antimony trioxide based flame retardants must also meet the <=1000ppm threshold requirement.

(3) MSL, Peak Temp. - The Moisture Sensitivity Level rating according to the JEDEC industry standard classifications, and peak solder temperature.

(4) There may be additional marking, which relates to the logo, the lot trace code information, or the environmental category on the device.

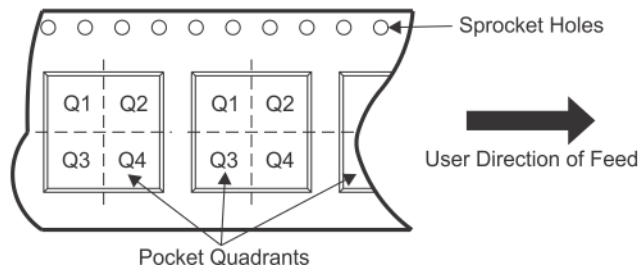
(5) Multiple Device Markings will be inside parentheses. Only one Device Marking contained in parentheses and separated by a "~" will appear on a device. If a line is indented then it is a continuation of the previous line and the two combined represent the entire Device Marking for that device.

(6) Lead finish/Ball material - Orderable Devices may have multiple material finish options. Finish options are separated by a vertical ruled line. Lead finish/Ball material values may wrap to two lines if the finish value exceeds the maximum column width.

**Important Information and Disclaimer:** The information provided on this page represents TI's knowledge and belief as of the date that it is provided. TI bases its knowledge and belief on information provided by third parties, and makes no representation or warranty as to the accuracy of such information. Efforts are underway to better integrate information from third parties. TI has taken and continues to take reasonable steps to provide representative and accurate information but may not have conducted destructive testing or chemical analysis on incoming materials and chemicals. TI and TI suppliers consider certain information to be proprietary, and thus CAS numbers and other limited information may not be available for release.

In no event shall TI's liability arising out of such information exceed the total purchase price of the TI part(s) at issue in this document sold by TI to Customer on an annual basis.

**TAPE AND REEL INFORMATION**

**QUADRANT ASSIGNMENTS FOR PIN 1 ORIENTATION IN TAPE**


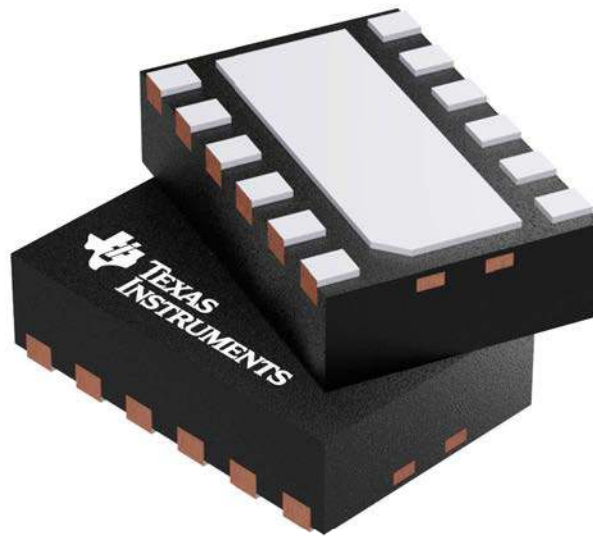
\*All dimensions are nominal

Device	Package Type	Package Drawing	Pins	SPQ	Reel Diameter (mm)	Reel Width W1 (mm)	A0 (mm)	B0 (mm)	K0 (mm)	P1 (mm)	W (mm)	Pin1 Quadrant
TPS61094DSSR	WSON	DSS	12	3000	180.0	8.4	2.25	3.25	1.05	4.0	8.0	Q1

**TAPE AND REEL BOX DIMENSIONS**


\*All dimensions are nominal

Device	Package Type	Package Drawing	Pins	SPQ	Length (mm)	Width (mm)	Height (mm)
TPS61094DSSR	WSON	DSS	12	3000	210.0	185.0	35.0



Images above are just a representation of the package family, actual package may vary.  
Refer to the product data sheet for package details.

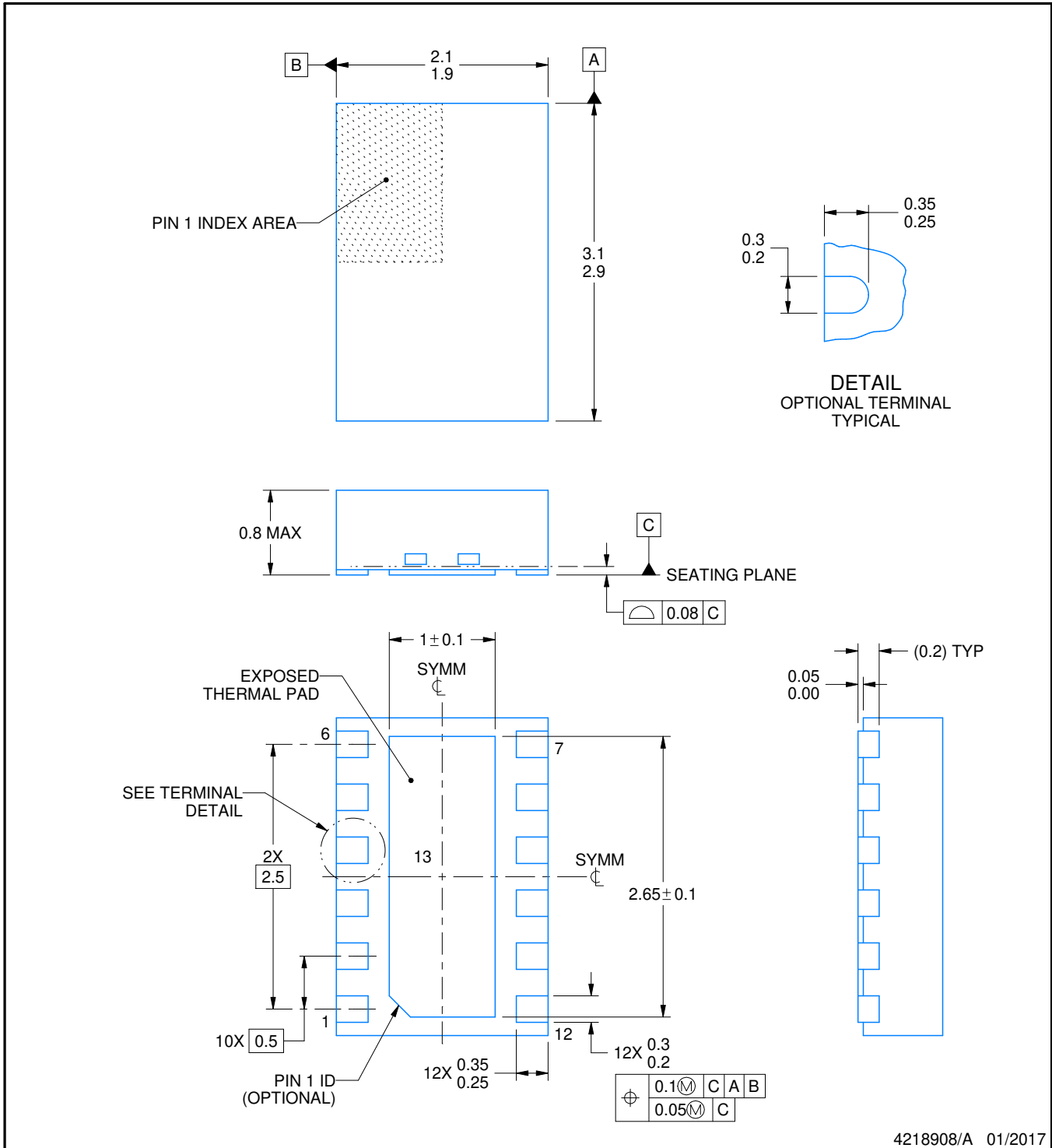
# DSS0012B



# PACKAGE OUTLINE

## WSON - 0.8 mm max height

PLASTIC SMALL OUTLINE - NO LEAD



4218908/A 01/2017

### NOTES:

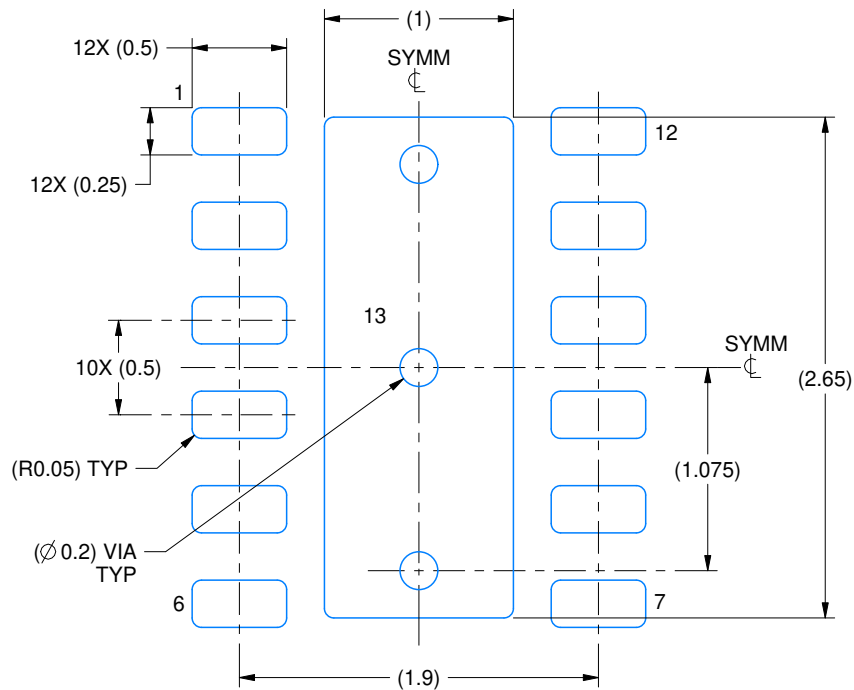
1. All linear dimensions are in millimeters. Any dimensions in parenthesis are for reference only. Dimensioning and tolerancing per ASME Y14.5M.
2. This drawing is subject to change without notice.
3. The package thermal pad must be soldered to the printed circuit board for optimal thermal and mechanical performance.

# EXAMPLE BOARD LAYOUT

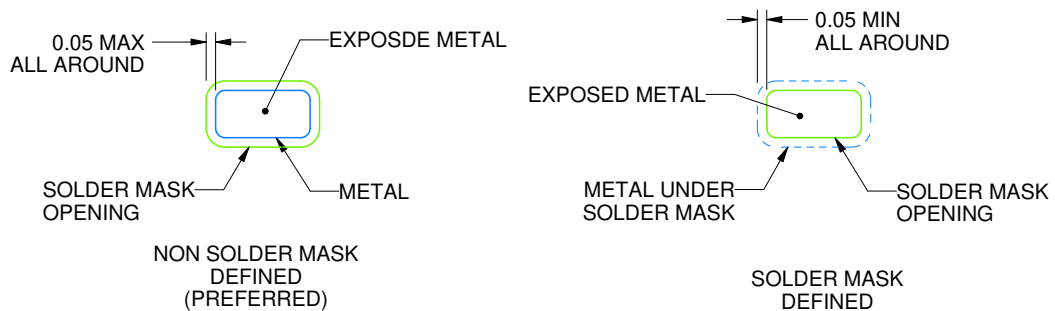
DSS0012B

WSON - 0.8 mm max height

PLASTIC SMALL OUTLINE - NO LEAD



LAND PATTERN EXAMPLE  
EXPOSED METAL SHOWN  
SCALE:25X



SOLDER MASK DETAILS

4218908/A 01/2017

NOTES: (continued)

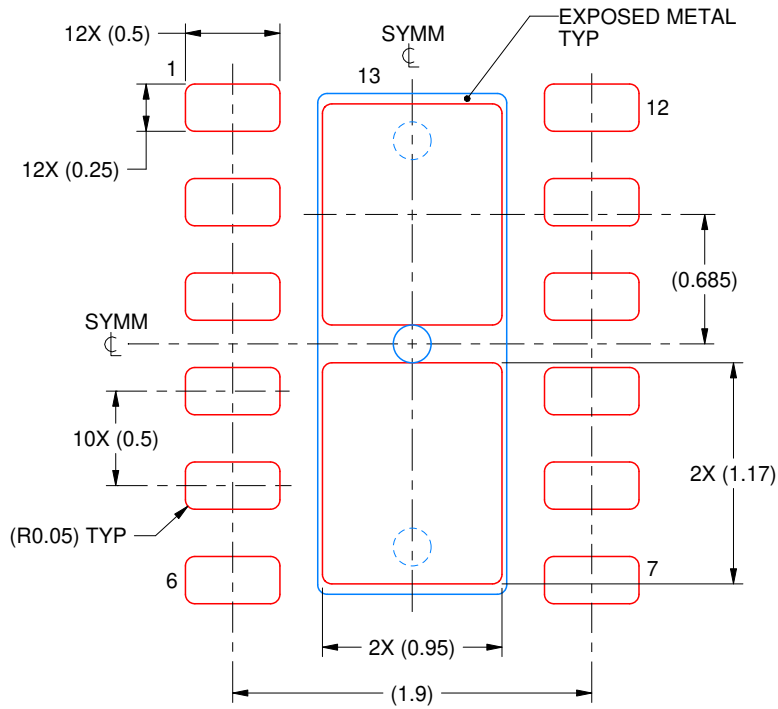
- This package is designed to be soldered to a thermal pad on the board. For more information, see Texas Instruments literature number SLUA271 ([www.ti.com/lit/sluea271](http://www.ti.com/lit/sluea271)).
- Vias are optional depending on application, refer to device data sheet. If any vias are implemented, refer to their locations shown on this view. It is recommended that vias under paste be filled, plugged or tented.

# EXAMPLE STENCIL DESIGN

DSS0012B

WSON - 0.8 mm max height

PLASTIC SMALL OUTLINE - NO LEAD



SOLDER PASTE EXAMPLE  
BASED ON 0.125 mm THICK STENCIL

EXPOSED PAD 13:  
83% PRINTED SOLDER COVERAGE BY AREA UNDER PACKAGE  
SCALE:25X

4218908/A 01/2017

NOTES: (continued)

6. Laser cutting apertures with trapezoidal walls and rounded corners may offer better paste release. IPC-7525 may have alternate design recommendations.



## IMPORTANT NOTICE AND DISCLAIMER

TI PROVIDES TECHNICAL AND RELIABILITY DATA (INCLUDING DATA SHEETS), DESIGN RESOURCES (INCLUDING REFERENCE DESIGNS), APPLICATION OR OTHER DESIGN ADVICE, WEB TOOLS, SAFETY INFORMATION, AND OTHER RESOURCES "AS IS" AND WITH ALL FAULTS, AND DISCLAIMS ALL WARRANTIES, EXPRESS AND IMPLIED, INCLUDING WITHOUT LIMITATION ANY IMPLIED WARRANTIES OF MERCHANTABILITY, FITNESS FOR A PARTICULAR PURPOSE OR NON-INFRINGEMENT OF THIRD PARTY INTELLECTUAL PROPERTY RIGHTS.

These resources are intended for skilled developers designing with TI products. You are solely responsible for (1) selecting the appropriate TI products for your application, (2) designing, validating and testing your application, and (3) ensuring your application meets applicable standards, and any other safety, security, regulatory or other requirements.

These resources are subject to change without notice. TI grants you permission to use these resources only for development of an application that uses the TI products described in the resource. Other reproduction and display of these resources is prohibited. No license is granted to any other TI intellectual property right or to any third party intellectual property right. TI disclaims responsibility for, and you will fully indemnify TI and its representatives against, any claims, damages, costs, losses, and liabilities arising out of your use of these resources.

TI's products are provided subject to [TI's Terms of Sale](#) or other applicable terms available either on [ti.com](https://www.ti.com) or provided in conjunction with such TI products. TI's provision of these resources does not expand or otherwise alter TI's applicable warranties or warranty disclaimers for TI products.

TI objects to and rejects any additional or different terms you may have proposed.

Mailing Address: Texas Instruments, Post Office Box 655303, Dallas, Texas 75265  
Copyright © 2023, Texas Instruments Incorporated