

© COPYRIGHT 1978 BY AMP INCORPORATED, HARRISBURG, PA. ALL INTERNATIONAL RIGHTS RESERVED. AMP INCORPORATED PRODUCTS COVERED BY U. S. AND FOREIGN PATENTS AND/OR PATENTS PENDING.

REVISIONS				DATE	APPROVED
P	F	ZONE	LTR		
		H		REV PER OG3C-0026-05	24 JAN 05 DS

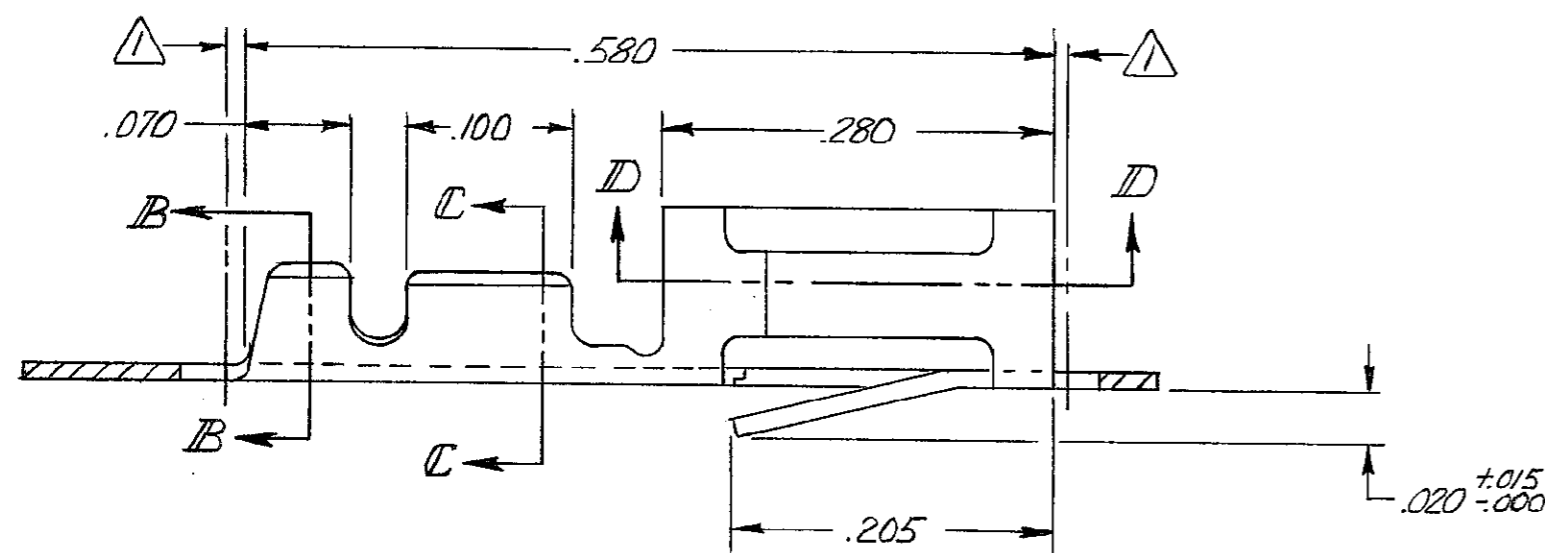

- 1. .010 MAX CUT-OFF TAB FOR LOOSE PIECE.
- 2. GOLD FLASH OVER .000050 NICKEL ENTIRE CONTACT, .000015 GOLD ON CONTACT AREA
- 3. GOLD FLASH OVER .000050 NICKEL ENTIRE CONTACT .000030 GOLD ON CONTACT AREA.
- 4. .000016 MIN. TIN.
- 5. LUBRICATED
- 6. POINT OF MEASUREMENT FOR PLATING THICKNESS.
- 7. .000015 GOLD ON CONTACT AREA, .000050-.000100 BRIGHT TIN-LEAD ON TERMINATION AREA, ALL OVER .000050 NICKEL ENTIRE TERMINAL.
- 8. .000030 GOLD ON CONTACT AREA, .000050-.000100 BRIGHT TIN-LEAD ON TERMINATION AREA, ALL OVER .000050 NICKEL ENTIRE TERMINAL.
- 9. OBSOLETE PART NUMBER.

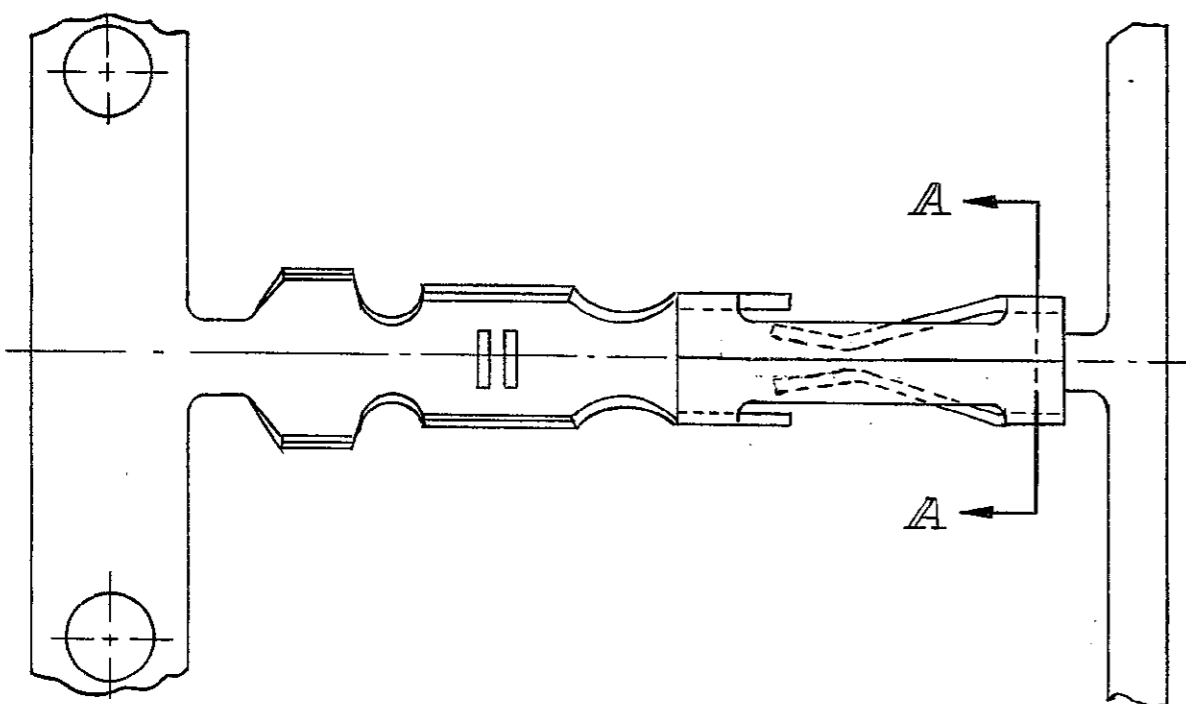
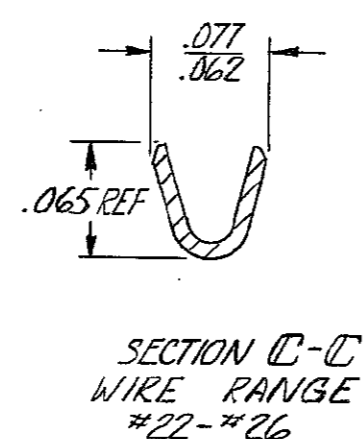
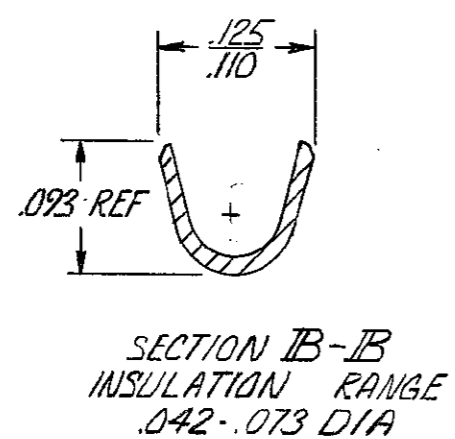
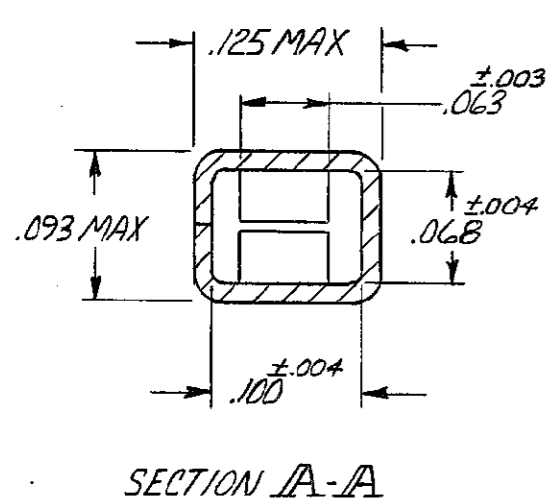
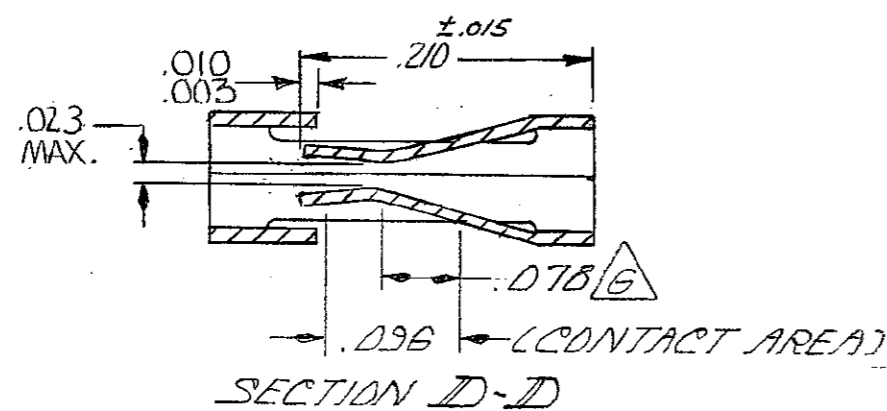
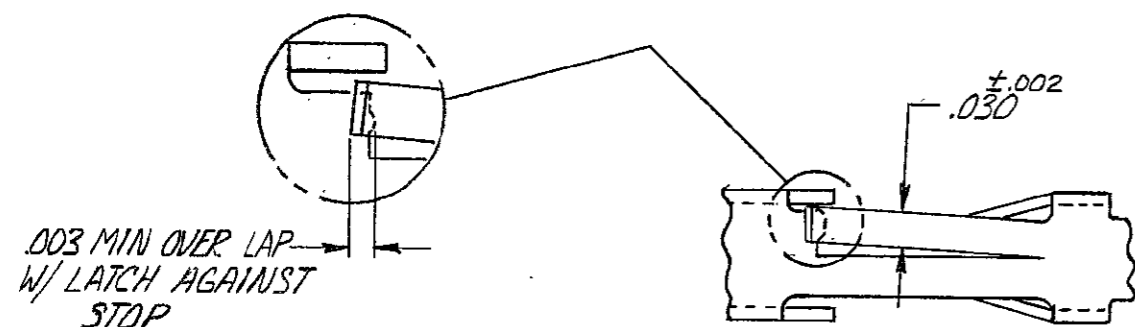

FINISH	LOOSE PIECE P/N	PART NO
8	9 102106-5	102102-7
7	9 102106-4	102102-6
4	5 102106-3	102102-5
3	102106-2	102102-2
2	9 102106-1	102102-1

UNLESS OTHERWISE SPECIFIED DIMENSIONS ARE IN INCHES. TOLERANCES ON: DECIMALS ±.005 ANGLES ±	CONTRACT NO	AMP INCORPORATED Harrisburg, Pa.
	DR <i>H. Bedwin</i> 4-12-78	
MATERIAL PHOS. BRONZE	CHK <i>B. Wolfe</i> 4-27-78	SIZE CODE IDENT NO DRAWING NO C 00779 102102
FINISH SEE TABLE	APPR <i>G. Zimmerman</i> 4/28/78	SCALE
	APPD <i>Bennett</i> 5/1/78	SHEET
	DSGN APPD	
	OTHER APPD	