

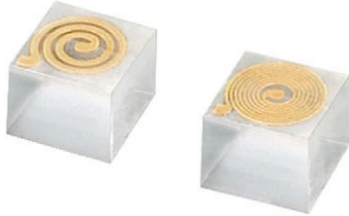

High Frequency Wire Bondable RF Spiral Inductor, 0.030" x 0.030"



RFLW series of thin film spiral inductors on quartz are designed for RF circuits that require wire bondable components. High precision equivalent circuit modeling enables accurate computer simulation of component performance. Measured S parameter files are also available upon request.

In many RF applications, correct component selection is achieved through experimentation. To help designers during the design process, a sample kit of standard values is available.

Additional values and form factors available upon request.

FEATURES

- High frequency
- Wire bond assembly
- Small size: 0.030" x 0.030" x 0.020"
- Low DCR, high Q
- Low parasitic capacitance, high SRF
- Equivalent circuit model enclosed
- S parameter files available for download
- Sample kit available
- Material categorization: for definitions of compliance please see www.vishay.com/doc?99912



APPLICATIONS

- RF choking for DC biasing
- RF tuning circuits
- Lumped element filters

STANDARD ELECTRICAL SPECIFICATIONS		
PARAMETER	VALUE	UNIT
Inductance Range ⁽¹⁾	0.003 to 0.03	μH
Tolerance ⁽²⁾	± 20	%
Max. Power Handling ⁽³⁾	125	mW
Operating Temperature	-55 to +125	°C
Storage Temperature	-55 to +125	°C
Stability, 1000 h, +125 °C, 125 mW	2.0 max. ΔR/R	%
ESD: AEC-Q200-002, component classification 5B (up to 16 kV)	5.0 max. ΔR/R	%

Notes

- ⁽¹⁾ Custom values available upon request. See custom design section below
- ⁽²⁾ Main source of value tolerance is due to variation in wire bonds. See "test fixture" section below
- ⁽³⁾ Maximum rated power of 125 mW at 70 °C, linearly de-rated to zero at 125 °C

RF CHARACTERISTICS - TYPICAL VALUES								
PART NUMBER	INDUCTANCE (nH)		DCR (Ω)	IN-CIRCUIT INDUCTANCE ⁽¹⁾ (nH)	IN-CIRCUIT DCR ⁽¹⁾ (Ω)	Q (UNITLESS)		SRF (GHz)
	250 MHz	1000 MHz				250 MHz	1000 MHz	
RFLW3N3900C	3.9	3.9	0.3	5	0.4	14	17	> 6
RFLW3N6700C	6.7	6.7	0.6	8	0.7	13	16	> 6
RFLW3N9000C	9	9	1.0	10	1.1	12	15	> 6
RFLW3N1100B	11	11	1.2	12	1.3	11	14	> 6
RFLW3N2000B	20	20	1.6	21	1.7	12	12	> 6
RFLW3N3000B	30	30	2.5	31	2.6	13	13	> 6

Note

- ⁽¹⁾ Including the added inductance and resistance of typical bond wires at 250 MHz. See equivalent circuit section below

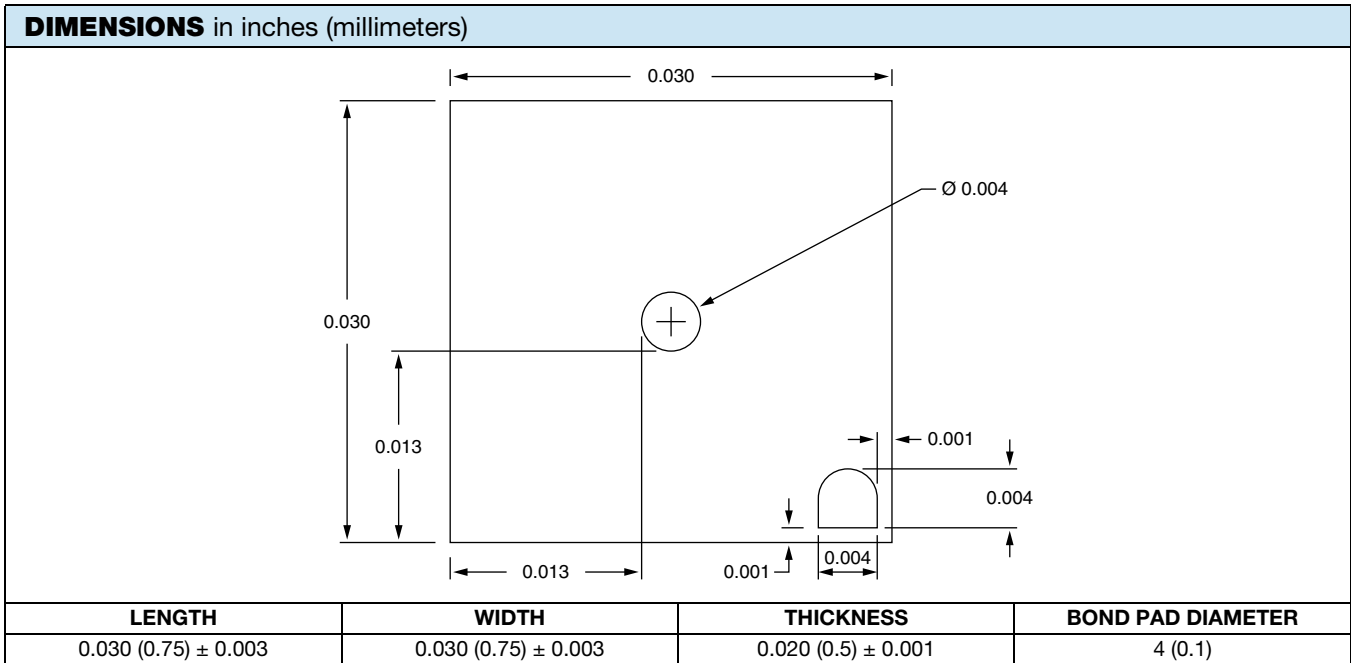

MECHANICAL SPECIFICATIONS	
Chip substrate material	Quartz
Conductor material	Gold
Conductor thickness	5 μm ± 20 %
Bond pad diameter	0.004"

ATTACHMENT NOTES

RFLW inductors are a robust wirebondable thin film product that requires careful attention to tooling set-up during the wire bonding process. Excessive thermo-mechanical wire bonding forces may result in damaging the underlying quartz substrate and cause wire bond failures.

GLOBAL PART NUMBER INFORMATION														
Global Part Number: RFLW3N2000BMNS														
Global Part Number Description: RFLW 30 x 30 NO PASS 20 nH 20 % WS														
R	F	L	W	3	N	2	0	0	0	B	M	N	W	S
MODEL	SIZE	PASSIVATION	INDUCTANCE (nH)	INDUCTANCE MULTIPLIER CODE	TOLERANCE CODE	SPECIAL	PACKAGING CODE							
RFLW	3 = 30 x 30 5 = 50 x 50	N = none	First 4 digits are significant figures of capacitance	C = 0.001 B = 0.01 A = 0.1	M = 20 % L = 25 %	N = none	WAFFLE WS = 100 min., 1 mult.							

EQUIVALENT CIRCUIT

The inductor's spiral trace presents a substantial amount of series resistance, and the close spacing of spiral turns present measurable amounts of stray capacitance that interact with the inductive characteristics.

For accurate modeling of the RFLW component in-circuit performance, measured S parameter files are available upon request. Another useful tool commonly used to model the behavior of electronic components at high frequency is the equivalent circuit model. While the equivalent circuit model accurately predicts the reactive part of the total impedance, it fails to determine the real part of the response at high frequency. This is due to the fact that the model does not include skin and proximity effects that significantly increase the real part of the impedance as the frequency rises.

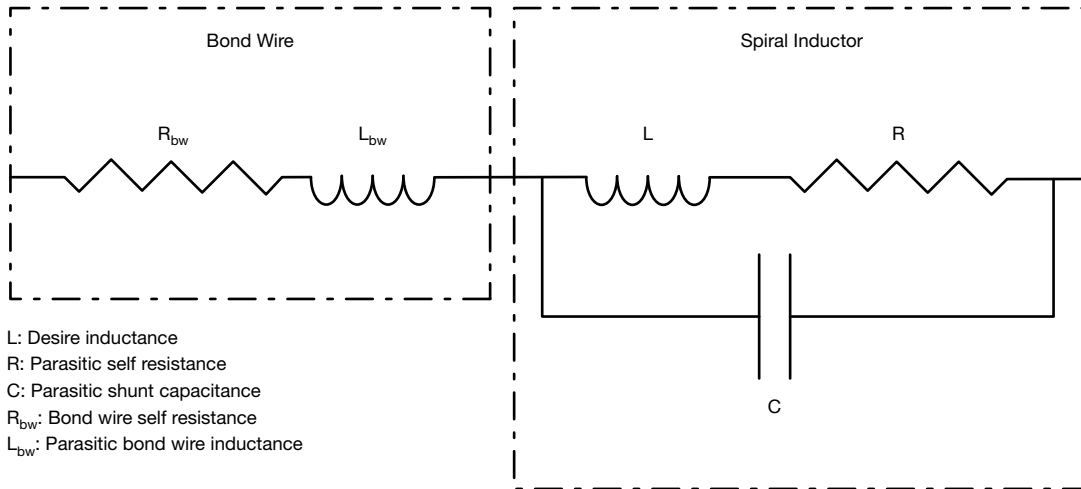

L: Desire inductance
 R: Parasitic self resistance
 C: Parasitic shunt capacitance
 R_{bw} : Bond wire self resistance
 L_{bw} : Parasitic bond wire inductance

Equivalent Circuit Model

The equivalent circuit values are presented in the table below:

EQUIVALENT CIRCUIT MODEL - TYPICAL VALUES				
INDUCTANCE (nH) L	DCR (Ω) ⁽¹⁾	SHUNT CAPACITANCE (fF) C	L_{bw} (nH)	R_{bw} ⁽²⁾ (Ω)
3.9	0.3	1	1.2	0.09
6.7	0.6	1	1.2	0.09
9	1.0	1	1.2	0.09
11	1.2	5	1.2	0.09
20	1.6	10	1.2	0.09
30	2.5	11	1.2	0.09

Notes

- (1) DCR tolerance $\pm 20\%$
- (2) Typical bond wires are approximated as being 1.25 mil in diameter gold, totaling a length of 3 mil. The resistance listed above includes the added effect of the bond wire adhesion to the circuit board and component

TEST FIXTURE

The results presented in the datasheet were obtained by assembling the components onto a thin film test fixture using non-conducting epoxy and 1.25 mil diameter gold bond wires.

Measurements were conducted using an HP 8753E network analyzer with cascade micro-tech air coplanar probes.

The parasitic elements of the bond wires are a major contributor to the tolerance of the lower value components. We consider the following bond-wire geometry to be typical for the assembly of the RFLW pars:

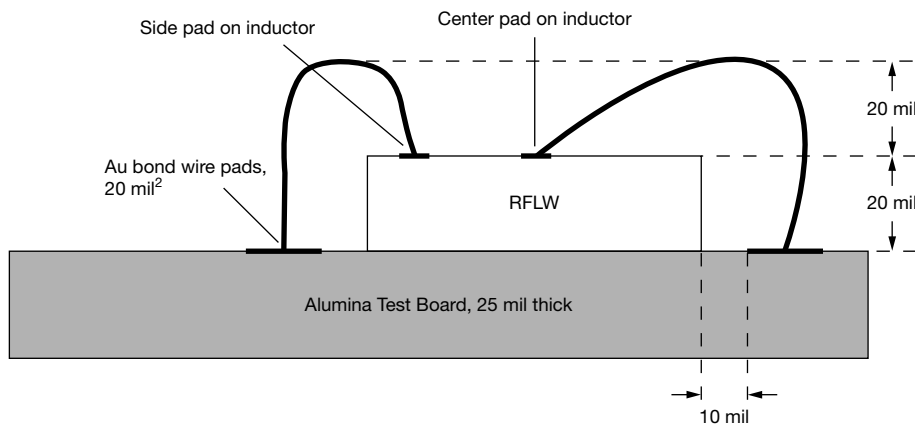

Text Fixture Diagram



TYPICAL COMPONENT PERFORMANCE

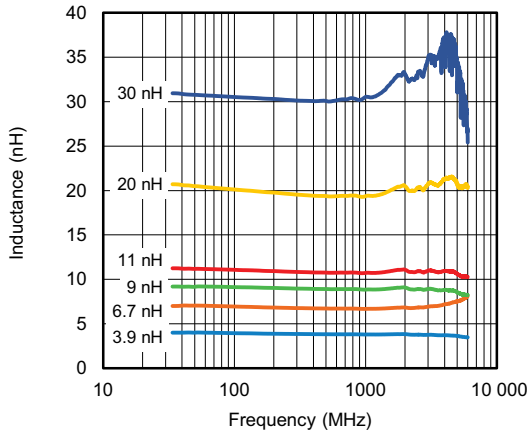

Inductance vs. Frequency

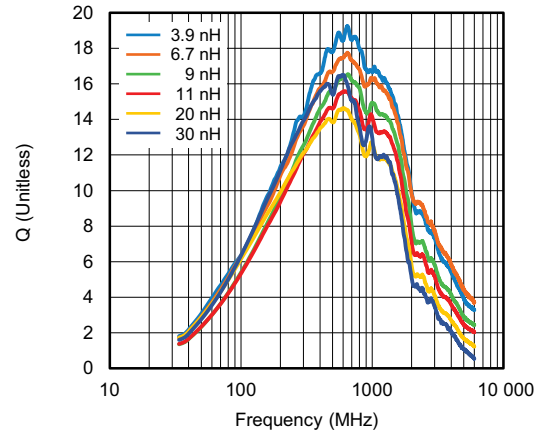

Quality Factor vs. Frequency

LAYOUT CONSIDERATIONS

The RF spiral inductor is electrically connected to the circuit by wire bonds. All wire bonds add parasitic inductance and resistance, as shown in the schematic drawing above.

It is important to note that setup variations might affect the performance of the component. Special care must be given to minimize these effects by careful design of the component host circuit board. The following aspects should be considered:

- Bond wire length should be minimized. The bond wire added inductance can be roughly estimated at 0.75 nH per mil of 1.25 mil diameter gold wire.
- Any ground plane directly under the component will increase the parasitic shunt capacitance. This will cause self resonance at lower frequencies.
- The epoxy used to attach the component is the limiting factor in power handling. Applications that require high power handling are recommended to use high temperature epoxy and to insure adequate heat sinking.

CUSTOM DESIGNED SPIRAL INDUCTORS

Vishay EFI will custom design and measure additional values and form factors upon request.

Typical inductance density is limited to: ~ 110 nH/mm²

It is important to note, that both series resistance and SRF characteristics will degrade as inductance values approach the inductance density limit presented above.



Disclaimer

ALL PRODUCT, PRODUCT SPECIFICATIONS AND DATA ARE SUBJECT TO CHANGE WITHOUT NOTICE TO IMPROVE RELIABILITY, FUNCTION OR DESIGN OR OTHERWISE.

Vishay Intertechnology, Inc., its affiliates, agents, and employees, and all persons acting on its or their behalf (collectively, "Vishay"), disclaim any and all liability for any errors, inaccuracies or incompleteness contained in any datasheet or in any other disclosure relating to any product.

Vishay makes no warranty, representation or guarantee regarding the suitability of the products for any particular purpose or the continuing production of any product. To the maximum extent permitted by applicable law, Vishay disclaims (i) any and all liability arising out of the application or use of any product, (ii) any and all liability, including without limitation special, consequential or incidental damages, and (iii) any and all implied warranties, including warranties of fitness for particular purpose, non-infringement and merchantability.

Statements regarding the suitability of products for certain types of applications are based on Vishay's knowledge of typical requirements that are often placed on Vishay products in generic applications. Such statements are not binding statements about the suitability of products for a particular application. It is the customer's responsibility to validate that a particular product with the properties described in the product specification is suitable for use in a particular application. Parameters provided in datasheets and / or specifications may vary in different applications and performance may vary over time. All operating parameters, including typical parameters, must be validated for each customer application by the customer's technical experts. Product specifications do not expand or otherwise modify Vishay's terms and conditions of purchase, including but not limited to the warranty expressed therein.

Hyperlinks included in this datasheet may direct users to third-party websites. These links are provided as a convenience and for informational purposes only. Inclusion of these hyperlinks does not constitute an endorsement or an approval by Vishay of any of the products, services or opinions of the corporation, organization or individual associated with the third-party website. Vishay disclaims any and all liability and bears no responsibility for the accuracy, legality or content of the third-party website or for that of subsequent links.

Except as expressly indicated in writing, Vishay products are not designed for use in medical, life-saving, or life-sustaining applications or for any other application in which the failure of the Vishay product could result in personal injury or death. Customers using or selling Vishay products not expressly indicated for use in such applications do so at their own risk. Please contact authorized Vishay personnel to obtain written terms and conditions regarding products designed for such applications.

No license, express or implied, by estoppel or otherwise, to any intellectual property rights is granted by this document or by any conduct of Vishay. Product names and markings noted herein may be trademarks of their respective owners.