



acam-messelectronic gmbH

is now

Member of the ams Group

The technical content of this acam-messelectronic document is still valid.

Contact information:

Headquarters:

ams AG

Tobelbader Strasse 30

8141 Premstaetten, Austria

Tel: +43 (0) 3136 500 0

e-Mail: ams_sales@ams.com

Please visit our website at www.ams.com



Time-to-Digital Converter

Target Specification

TDC-GP2

**2-channel Universal
Time-to-Digital Converter**

26th May 2010
Document-No.: DB_GP2_e V2.0

Published by acam-messelectronic gmbh

© **acam-messelectronic gmbh 2010**

Disclaimer / Notes

The information provided by this data sheet is believed to be accurate and reliable. However, no responsibility is assumed by acam for its use, nor for any infringements of patents or other rights of third parties that may result from its use. The information is subject to change without notice and is provided „as is“ without warranty of any kind (expressed or implied). Picostrain is a registered trademark of acam. All other brand and product names in this document are trademarks or service marks of their respective owners.

Support

For a complete listing of direct sales, distributors and sales representatives visit the acam website at:

<http://www.acam.de/company/distributors>

For technical support you can contact the acam support team in the headquarter in Germany or the Distributor in your country. The contact details of acam in Germany are:

sales@acam.de or by phone +49-7244-74190.

Table of Contents

1 Overview	1-4
2 Characterisitcs & Specifications	2.1 Electrical Characteristics 2-1
	2.2 Timings 2-3
	2.3 Pin Description 2-6
	2.4 Package Drawings 2-7
	2.5 Power Supply 2-8
	2.6 Register settings 2-10
3 Measurement Mode 1	3.1 General Description 3-1
	3.2 Measurement Flow 3-2
4 Measurement Mode 2	4.1 General Descriptionweis 4-1
	4.2 Measurement Flow 4-2
	4.3 Stop Masking 4-7
5 Details and Special Functions	5.1 Oscillator 5-1
	5.2 Fire-pulse Generator 5-4
	5.3 Temperature Measurement 5-7
	5.4 SPI-interface 5-10
	5.5 Fast Initialization 5-11
	5.6 Noise Unit 5-11
6 Applications	6-1
7 Miscellaneous	7-1

1 Overview

1.1 Introduction

TDC-GP2 is the next generation of acam generalpurpose TDCs. Higher resolution and smaller package size make it ideal for cost sensitive industrial applications. With special functional blocks like a fire-pulse generator, stop-enable, temperature measurement, and clock control it is perfectly suited for ultrasonic flow-meter and heat-meter applications.

1.2 Features

Measurement Mode 1

- 2 channels with typ. 50 ps resolution rms
- Measurement range 3.5 ns to 1.8 μ s (0 to 1.8 μ s between stop channels)
- 15 ns pulse-pair resolution with 4-fold multihit capability
- 4 events can be measured arbitrarily against each other
- Trigger to rising or/and falling edge
- Windowing for precise stop enable

Measurement Mode 2

- 1 channel with typ. 50 ps resolution rms
- Measurement range 500 ns to 4 ms
- 2 x CLKHS pulse-pair resolution with 3-fold multihit capability
- Trigger to rising or/and falling edge
- Each of the 3 events can be assigned to an adjustable measuring window with 10ns resolution

Temperature Measurement

- 2 or 4 sensors
- PT500/PT1000 or higher
- Very high resolution: 16 Bit eff. (0.004 °C resolution for platinum sensors)
- Ultra low current (0.08 μ A when measuring every 30 seconds)

General

- QFN 32 package
- I/O voltage 1.8 V to 5.5 V
- Core voltage 1.8 V to 3.6 V
- 1 MHz continuous data rate max.
- Temperature range – 40 °C to 125 °C
- 4 wire SPI interface
- Fire pulse generator
- Clock calibration unit
- Precise stop enable by windowing
- Trigger to rising and/or falling edge

1.3 Blockdiagram

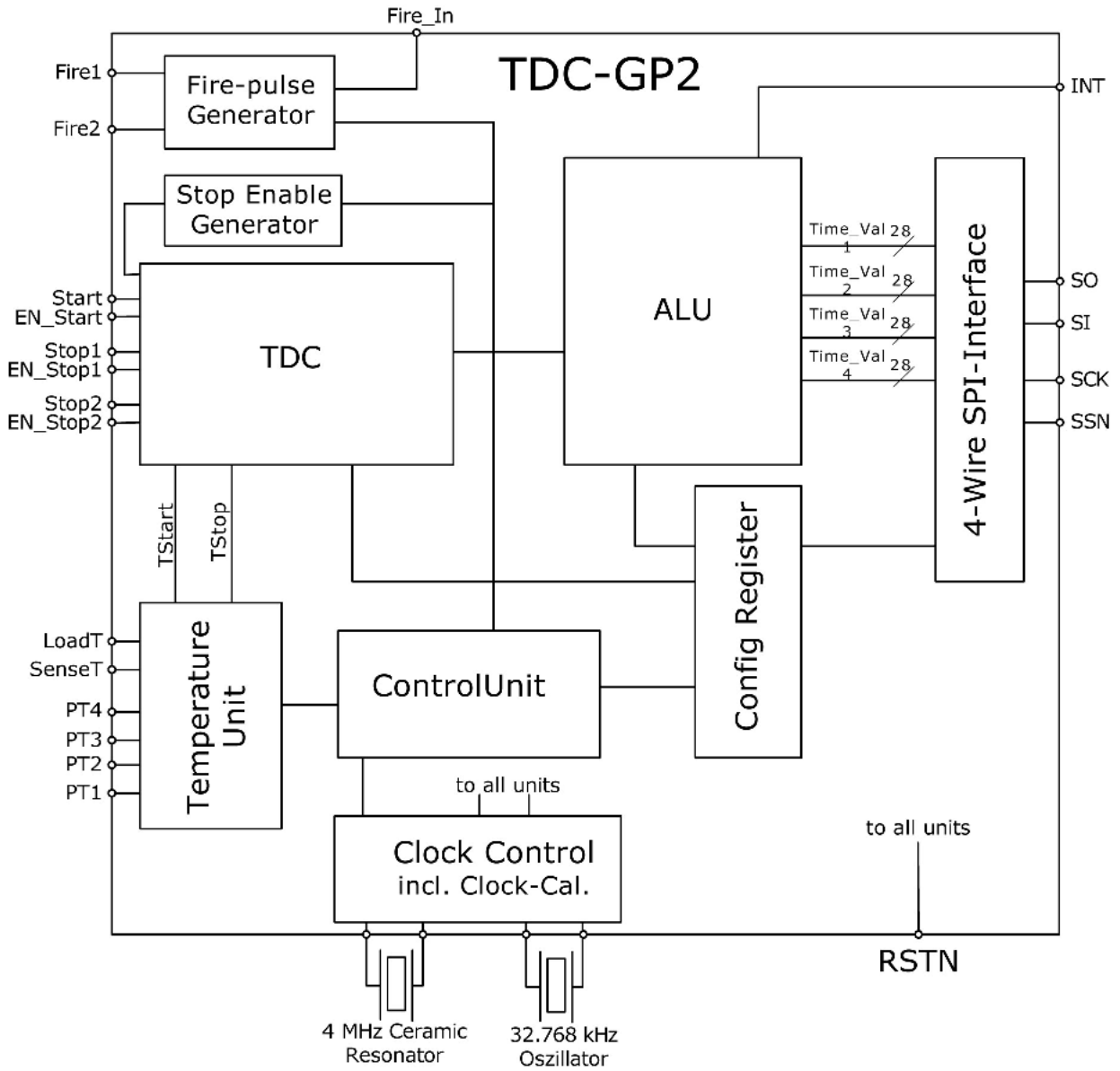

2 Characterisitics & Specifications

2.1 Electrical Characteristics

Absolute Maximum Ratings

Supply voltage

V_{cc} vs. GND - 0.3 to 4.0 V

V_{io} vs. GND - 0.3 to 7.0 V

Continous current into Output-Pin (Iout) 30 mA

Storage temperature (Tstg) - 65 to 150 °C

Junction temperature (Tj) max.125 °C

Recommended Operating Conditions

Symbol	Parameter	Conditions	Min	Typ	Max	Unit
V_{cc}	Core supply voltage*	$V_{io} > V_{cc}$	1.8		3.6	V
V_{io}	I/O supply voltage		1.8		5.5	V
tri	Normal Input Rising Time				50	ns
tfa	Normal Input Falling Time				50	ns
tri	Schmitt Trigger Rising Time				5	ms
tfa	Schmitt Trigger Falling Time				5	ms
Ta	Ambient Temperature	Tj must not exceed 125°C	-40		120	°C

*including the oscillator pins XIN, XOUT, Clk32In, Clk32Out

DC Characteristics ($V_{io} = V_{cc} = 3.3 \text{ V} \pm 0.3 \text{ V}$, $T_j = -40$ to $+85^\circ\text{C}$)

Symbol	Parameter	Conditions	Min	Typ	Max	Unit
I32	Current 32 kHz	Icc + Iio, only 32kHz oscillator running, $V_{cc} = 3.6 \text{ V}$		4.5		μA
Ihs	Current 4 Mhz	Icc + Iio, only ClkHS running cont. at 4MHz, $V_{cc} = 3.6 \text{ V}$		260		μA
Itmu	Current time measuring unit	only during active time measurement		15		mA
Iddq	Quiescent current	all clocks off, $V_{io} = V_{cc} = 3.6 \text{ V}$ @ 85 °C		<150		nA
Ii	Input Leakage Current		-1		+1	μA
Voh	High Level Output Voltage	Ioh= tbd mA $V_{io}=\text{Min.}$	$V_{io}-0.4$			V

Symbol	Parameter	Conditions	Min	Typ	Max	Unit
V _{ol}	Low Level Output Voltage	I _{ol} = t _{bd} mA, V _{io} =Min			0.4	V
V _{ih}	High Level Input Voltage	LVTTL Level, V _{io} = Max.	2.0			V
V _{il}	Low Level Input Voltage	LVTTL Level, V _{io} = Min.			0.8	V
V _{th}	High Level Schmitt Trigger Voltage		1.1		2.4	V
V _{tl}	Low Level Schmitt Trigger Voltage		0.6		1.8	V
V _h	Schmitt Trigger Hysteresis		0.1			V

Terminal Capacitance

Symbol	Terminal	Condition	Rated Value			Unit
			Min.	Typ.	Max.	
C _i	Input	measured @ V _{cc} = V _{io} , f = 1 MHz, T _a = 25°C			10	pF
C _o	Output				10	
C _{io}	Bidirectional				10	

Time Measuring Unit

Symbol	Terminal	Condition	Rated Value			Unit
			Min.	Typ.	Max.	
	LSB	V _{io} = V _{cc} = 3.3 V	-40 °C	25 °C	85 °C	ps
			3.6 V	3.3 V	3.0 V	
			35	63	111	
		V _{io} = V _{cc} = 2.5 V	-40 °C	25 °C	85 °C	
			2.75 V	2.5 V	2.25 V	
			38	76	156	
	Standard Deviation	V _{io} =3.3 V, V _{cc} =3.3 V	2.75 V	2.5 V		
		T _a = 25°C	-	50	-	

Temperature Measuring Unit

Symbol	Terminal	Condition	Rated Value			Unit
			Min.	Typ.	Max.	
	Resolution RMS	$V_{io} = V_{cc} = 3.3 \text{ V}$		16.0		Bit
	SNR	PT1000		96		dB
	Absolute Gain-Error	150 nF Capacitance		0,1		%
	Gain-Drift vs. V_{io}			0,08		%/V
	Gain-Drift vs. Temp			0,0008		%/K
	Uncalibrated Offset			<0.01		%
	Offset Drift vs. Temp			<0,2		ppm/K
	PSRR			>100		dB

2.2 Timings

At $V_{cc} = 3.3 \text{ V} \pm 0.3 \text{ V}$, ambient temperature $-40 \text{ }^\circ\text{C}$ to $+85 \text{ }^\circ\text{C}$ unless otherwise specified

Oscillator

Symbol	Parameter	Min.	Typ.	Max.	Unit
Clk32	32 kHz reference oscillator		32,768		kHz
toszst	Oscillator start-up time with ceramic resonator		200		μs
toszst	Oscillator start-up time with crystal oscillator		5		ms
ClkHS	High-speed reference oscillator	2		8	MHz

Serial Interface

Symbol	Parameter	Max. @ $V_{io} =$			Unit
		2.0 V	2.5 V	3.3 V	
fclk	Serial clock frequency	10	20	25	MHz

Symbol	Parameter	Min. @ $V_{io} =$			Unit
		2.0 V	2.5 V	3.3 V	
tpwh	Serial clock, pulse width high	50	25	20	ns
tpwl	Serial clock, pulse width low				ns
tsussn	SSN enable to valid latch clock	20	40	10	ns
tpwssn	SSN pulse width between write cycles	50	30	20	ns
thssn	SSN hold time after SCLK falling	70	40	25	ns
tsud	Data set-up time prior to SCLK falling	10	5	5	ns
thd	Data hold time before SCLK falling	10	5	5	ns

Symbol	Parameter	Max. @ Vio =			Unit
		1.8 V	2.5 V	3.3 V	
tvd	Data valid after SCLK rising	30	20	16	ns

Serial Interface (SPI compatible, Clock Phase Bit =1, Clock Polarity Bit =0):

Figure 2-1: SPI Write

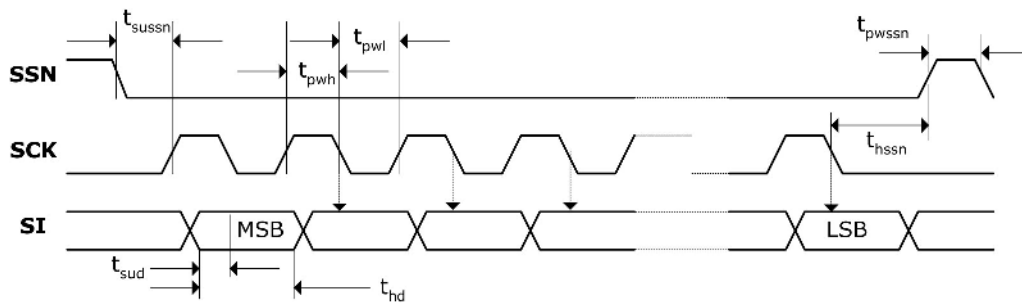
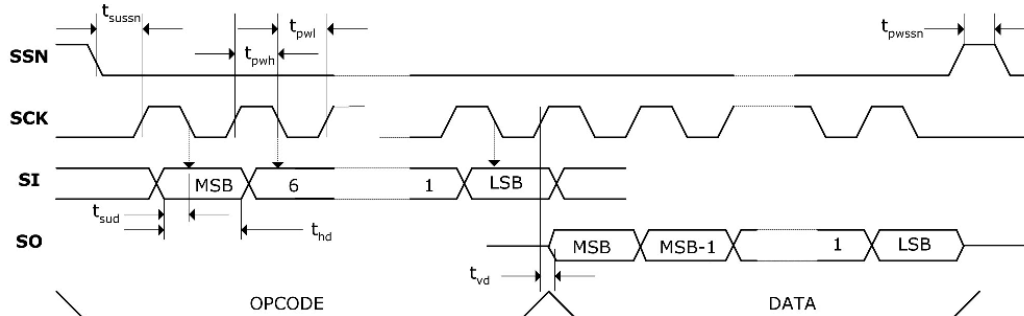

Figure 2-2: SPI Read



8-Bit Opcodes:

MSB							LSB	Description
1	0	0	0	0	ADR2	ADR1	ADRO	Write into address ADR
1	0	1	1	0	ADR2	ADR1	ADRO	Read from address ADR
0	1	1	1	0	0	0	0	Init
0	1	0	1	0	0	0	0	Power On Reset
0	0	0	0	0	0	0	1	Start_Cycle
0	0	0	0	0	0	1	0	Start_Temp
0	0	0	0	0	0	1	1	Start_Cal_Resonator
0	0	0	0	0	1	0	0	Start_Cal_TDC

Disable Timings

Figure 2-3:

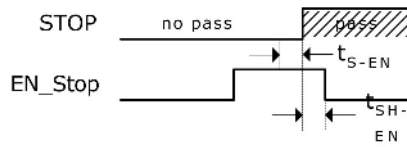

Spec	Description	Min (ns)	Max (ns)
tS-EN	Enable Setup Time	5 ns	-
tSH-EN	Enable Hold Time	5 ns	-

Reset Timings

Figure 2-4:

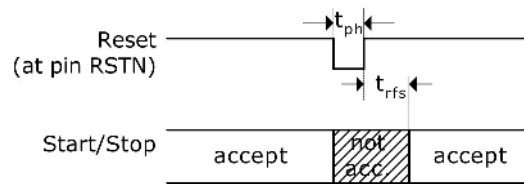

Spec	Description	Min (ns)	Max (ns)
t _{ph}	Reset pulse width	50 ns	-
t _{rfs}	Time after rising edge of reset pulse before hits are accepted	200 ns	-

2.3 Pin Description

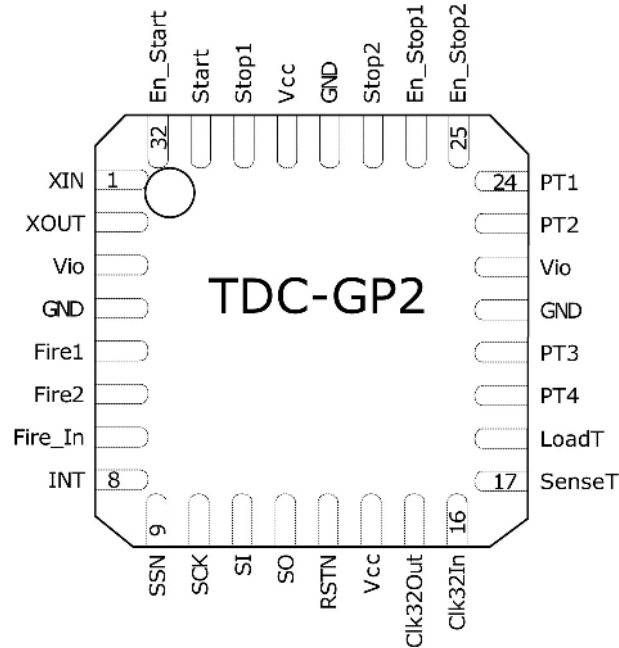

No.	Name	Description	Buffer type	Value	If not used
1	Xin	Oscillator driver in			GND
2	Xout	Oscillator driver out			
3	Vio	I/O – supply voltage			
4	GND	Ground			
5	Fire1	Fire pulse generator output 1	48 mA		
6	Fire2	Fire pulse generator output 2	48 mA		
7	Fire_In	Signal input for quasi “Sing Around”			GND
8	INTN	Interrupt flag	12 mA	LOW active	
9	SSN	Slave select	Schmitt trigger	LOW active	
10	SCK	Clock serial interface	Schmitt trigger		
11	SI	Data input serial interface	Schmitt trigger		
12	SO	Data output serial interface	12 mA tristate		
13	RSTN	Reset input	Schmitt trigger	LOW active	
14	Vcc	Core supply voltage			
15	Clk32Out	Output 32 kHz clock generator			n. c.
16	Clk32In	Input 32 kHz clock generator			GND

No.	Name	Description	Buffer type	Value	If not used
17	SenseT	Sense input temperature measurement	Schmitt trigger		GND
18	LoadT	Load output temperature measurement	24 mA		n.c.
19	PT4	Port 4 temperature measurement	48 mA		
20	PT3	Port 3 temperature measurement	48 mA		
21	GND	Ground			
22	Vio	I/O – supply voltage			
23	PT2	Port 2 temperature measurement	48 mA		
24	PT1	Port 1 temperature measurement	48 mA		
25	En_Stop2	Enable pin stop input 2	Schmitt trigger	HIGH active	Vio
26	En_Stop1	Enable pin stop input 1	Schmitt trigger	HIGH active	Vio
27	Stop2	Stop input 2			GND
28	GND	Ground			
29	Vcc	Core supply voltage			
30	Stop1	Stop input 1			GND
31	Start	Start input			
32	En_Start	Enable pin start input	Schmitt trigger	HIGH active	Vio

2.4 Package Drawings

Suitable socket: Plastronics 32QN50S15050D

Symbol	Dimension in Millimeters		
	Min.	Nom.	Max.
D	-	5	-
E	-	5	-
A	-	-	1
A1	0	-	-
b	0.17	-	0.3
e	-	0.5	-
L	0.3	-	0.5
G		3.24	

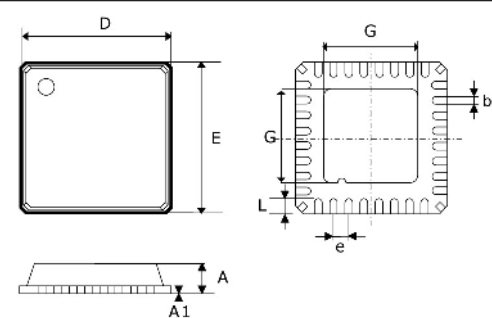

Center pad shall not be connected to GND.

Thermal resistance

Roughly 40 K/W at 0 m/s air flow, 37 K/W at 1 m/s air flow, 35 K/W at 2m/s air flow (values just for reference).

Soldering Temperature Profile

The temperature profile for infrared reflow furnace (in which the temperature is the resin's surface temperature) should be maintained within the range described below.

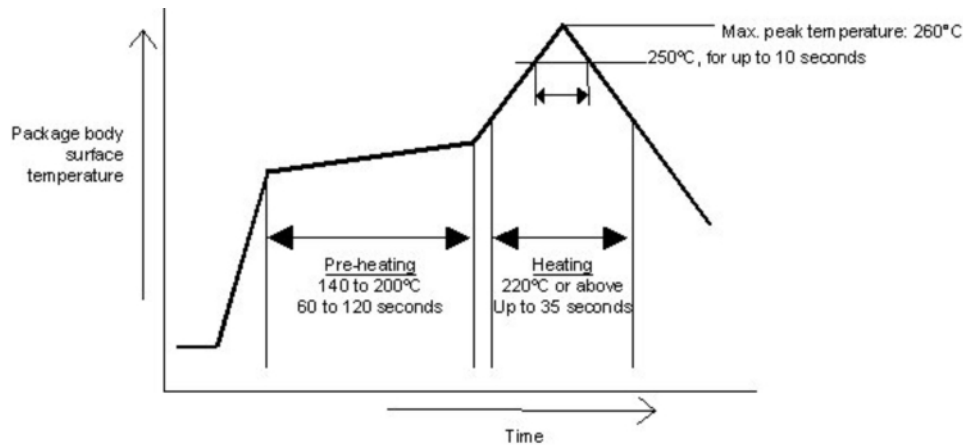

Maximum temperature

The maximum temperature requirement for the resin surface, given 260°C as the peak temperature of the package body's surface, is that the resin surface temperature must not exceed 250°C for more than 10 seconds. This temperature should be kept as low as possible to reduce the load caused by thermal stress on the package, which is why soldering for short periods only is recommended. In addition to using a suitable temperature profile, we also recommend that you check carefully to confirm good soldering results.

2.5 Power Supply

Supply voltage

Although the TDC-GP2 is a fully digital circuit, some analog measures affect the circuit. The reason is that the TDC is based on the internal analog measure 'propagation delay time' which is influenced by temperature and supply voltage. A good layout of the supply voltage is essential for good measurement results. It should be high capacitive and of low inductance.

The TDC-GP2 provides two pairs of power supply terminals:

- Vio - I/O supply voltage
- Vcc - Core supply voltage

All ground pins should be connected to a ground plane on the printed circuit board. Vio and Vcc should be provided by a battery or fixed linear voltage regulator. Do not use switched regulators to avoid disturbances caused by the I/O supply.

The measurement quality of a time-to-digital converter depends on a good power supply. The chip sees mainly pulsed current and therefore a sufficient bypassing is mandatory:

Vcc	100 μ F	(minimum 47 μ F)
Vio	10 μ F	(minimum 1 μ F)

The supply voltage should be provided through analog regulators. We strongly recommend not to use switch mode power supplies.

Current consumption

The current consumption is the sum from different parties (all data for Vio = Vcc = 3.6V):

Iddq	< 150 nA	Quiescent current,
I32	typ. 4.5 μ A	Current into the 32 kHz oscillator, turned on only if the 32 kHz oscillator is connected
Ihs	typ. 260 μ A/s * (active runtime)	Current into the high speed oscillator, Example: In ultrasonic flow-meters the high-speed oscillator is on for about 2ms only. The average current consumption is 260 μ A/s * 2 ms = 0.52 μ A
I _{tmu}	typ. 15 mA/s * (active measuring time)	Current into the time measuring unit, In measurement range 1 the time measuring unit is active for the start-stop time interval plus the calibration time interval of 2 periods of the reference clock per measurement. In measurement range 2 the time measuring unit is on for average 4 periods of the reference clock per measurement, two for the time measurement and two for calibration. Example: With 10 measurements per second in measurement range 2 and a 4 MHz reference clock the time measuring unit is active for only about 10 μ s. The average current is 15 mA/s * 10 μ s = 0.150 μ A.
I _{alu}	typ. 7 nA per calculation	Current into ALU during data processing including a calibration calculation. Example: At 1000 measurements per second with 3 stops per

start the ALU average current is $7 \text{ nA} * 3000 = 21 \mu\text{A}$.

IT typ. $2.5 \mu\text{As} * \text{measure rate}$ The current for a full temperature measurement is typ. $2.5 \mu\text{As}$.
 In heat-meters the temperature is measured typically once every 30 seconds. The average current is about $0.085 \mu\text{A}$

2.6 Register settings

Service bits are for acam testing and security purposes only, Please use the recommended values.

2.6.1 Write registers

Default values in second rows

Bit	Reg0	(*)	Reg1	(*)	Reg2	(*)	Reg3	(*)	Reg4	(*)	Reg5	(*)
23	FIRE#	0	HIT2	0	EN_INT	0	s.c.	0	s.c.	0	CONF_FIRE	0
22		0		1		0	s.c.	0	s.c.	0		0
21		0		0		1	EN_ERR_VAL	0	s.c.	1		0
20		0		1	RFEDGE2	0	SEL_TIMO_	1	s.c.	0	EN_STARTNOISE	0
19	DIV_FIRE	0	HIT1	0	RFEDGE1	0	MR2	1	s.c.	0	DIS_PhaseNoise	0
18		0		1	DELVAL1	0	DELVAL2	0	DELVAL3	0	REPEAT_FIRE	0
17		0		0		0		0		0		0
16		0		1		0		0		0		0
15	CALRES#	0	EN_FAST_INIT	0		0		0		0	PHASE_FIRE	0
14		0	s.c.	1		0		0		0		0
13	CikHSDiv	0	HITIN2	0		0		0		0		0
12		0		0		0		0		0		0
11	START_CikHS	0		0		0		0		0		0
10		1	HITIN1	0		0		0		0		0
9	PORT#	1		0		0		0		0		0
8	TCycle	0		0		0		0		0		0
7	No_FAKE	0	n.c	0		0		0		0		0
6	SelCikT	1	n.c	0		0		0		0		0
5	Calibrate	1	n.c	0		0		0		0		0
4	DisAutoCal	0	n.c	0		0		0		0		0
3	MRange2	1	n.c	0		0		0		0		0
2	NEG_STOP2	0	n.c	0		0		0		0		0
1	NEG_STOP1	0	n.c	0		0		0		0		0
0	NEG_START	0	n.c	0		0		0		0		0

s.c. = Special acam configuration bits, n.c. = not in use

(*) = Default value after Power On Reset

Short description of the bits:

Bits	Name	Description	Value
Reg 0			
0	NEG_START	Negation start input	0 = non-inverted input signal – rising edge 1 = inverted input signal – falling edge
1	NEG_STOP1	Negation stop 1 input	0 = non-inverted input signal – rising edge 1 = inverted input signal – falling edge
2	NEG_STOP2	Negation stop 2 input	0 = non-inverted input signal – rising edge 1 = inverted input signal – falling edge
3	MRange2	Switch to measurement range 2	0 = measurement range 1 1 = measurement range 2
4	DisAutoCal	Enables/disables auto-calibration run in the TDC	0 = auto-calibration after measurement 1 = auto-calibration disabled
5	Calibrate	Enables/disables calibration calculation in the ALU	0 = calibration off (only MR 1) 1 = calibration on
6	SeIClKt	Select reference signal for internal cycle clock for temperature measurement	0 = use 32,768 kHz as cycle clock 1 = use 128 * CLKHS as period for cycle clock (32µs with 4 MHz high speed clock signal)
7	FAKE#	Number of dummy cycles at the beginning of a temperature measurement	0 = 2 Fake measurements 1 = 7 Fake measurements
8	TCycle	Sets cycle time for temperature measurement	0 = 128 µs cycle time @ 4 MHz 1 = 512 µs cycle time @ 4 MHz (recommended)
9	PORT#	Sets number of ports used for temperature measurement	0 = 2 temperature ports (PT1 and PT2) 1 = 4 temperature ports
10-11	START_CLKHS	Switch on high-speed oscillator	0 = Oscillator off 1 = Oscillator on 2 = settling time = 640 µs 3 = settling time = 1280 µs (see Bug Report)
12-13	ClkHSDiv	Sets predivider for CLKHS	0 = divided by 1 1 = divided by 2 2 = divided by 4 3 = divided by 4
14-15	CALRES#	Sets number of periods used for calibrating the ceramic resonator	0 = 2 periods = 61.035 µs 1 = 4 periods = 122.07 µs 2 = 8 periods = 244.14 µs 3 = 16 periods = 488.281 µs
16-19	DIV_FIRE	Sets predivider for internal clock signal of fire pulse generator	0 = not permitted 1 = divided by 2 2 = divided by 3 3 = divided by 4 ... 15 = divided by 16

20-23	FIRE#	Sets number of pulses generated by fire pulse generator	0 = off 1 = 1 pulse 2 = 2 pulses 3 = 3 pulses ... 15 = 15 pulses
-------	-------	---	---

Reg 1				
8-10	HITIN1	Number of expected hits on channel 1	0 = stop channel 1 disabled 1 = 1 hit 2 = 2 hits 3 = 3 hits 4 = 4 hits 5 to 7 = not permitted	
11-13	HITIN2	Number of expected hits on channel 2	0 = stop channel 2 disabled 1 = 1 hit 2 = 2 hits 3 = 3 hits 4 = 4 hits 5 to 7 = not permitted	
15	EN_FAST_INIT	Enables fast init operation	0 = Fast init mode disabled 1 = Fast init mode enabled	
16-19	HIT1	Defines operator for ALU data post-processing MRange1: HIT1-HIT2 MRange2: HIT2-Start	MRange1: 0 = Start 1 = 1. Stop Ch1 2 = 2. Stop Ch1 3 = 3. Stop Ch1 4 = 4. Stop Ch1 5 = no action 6 = Cal1 Ch1 7 = Cal2 Ch1 9 = 1. Stop Ch2 A = 2. Stop Ch2 B = 3. Stop Ch2 C = 4. Stop Ch2	MRange2: 1 = Start
20-23	HIT2	Defines operator for ALU data post-processing MRange1: HIT1-HIT2 MRange2: HIT2-Start	MRange1: 0 = Start 1 = 1. Stop Ch1 2 = 2. Stop Ch1 3 = 3. Stop Ch1 4 = 4. Stop Ch1 5 = no action 6 = Cal1 Ch1 7 = Cal2 Ch1 9 = 1. Stop Ch2 A = 2. Stop Ch2 B = 3. Stop Ch2 C = 4. Stop Ch2	MRange2: 2 = 1. Stop Ch1 3 = 2. Stop Ch1 4 = 3. Stop Ch1

Reg 2			
0-18	DELVAL1	Delay value for internal stop enable unit, hit 1 channel 1. Fixed point number with 14 integer and 5 fractional digits in multiples of Tref	DELVAL1 = 0 to 16383.96875
19	RFEDGE1	Edge sensitivity channel 1	0 = rising or falling edge 1 = rising and falling edge
20	RFEDGE2	Edge sensitivity channel 1	0 = rising or falling edge 1 = rising and falling edge
21-23	EN_INT	Activates interrupt sources wired by OR	Bit 23 = Timeout interrupt enable Bit 22 = End Hits interrupt enable Bit 21 = ALU interrupt enable

Reg 3			
0-18	DELVAL2	Delay value for internal stop enable unit, hit 2 channel 1. Fixed point number with 14 integer and 5 fractional digits in multiples of Tref	DELVAL1 = 0 to 16383.96875
19-20	SEL_TIMO_MR2	Select predivider for timeout in measurement range 2	0 = 64 μ s 1 = 256 μ s 2 = 1024 μ s 3 = 4096 μ s @ 4 MHz ClkHS
21	EN_ERR_VAL	Timeout forces ALU to write 0xFFFFFFFF into the output register	0 = disabled 1 = enabled

Reg 4			
0-18	DELVAL1	Delay value for internal stop enable unit, hit 3 channel 1. Fixed point number with 14 integer and 5 fractional digits in multiples of Tref	DELVAL1 = 0 to 16383.96875

Reg 5			
0-15	PHASE_FIRE	Enables phase reversing for each pulse of a sequence of up to 15 possible pulses	0 = no inversion 1 = inversion
16-18	REPEAT_FIRE	Number of pulse sequence repetition for "quasi-sing-around"	0 = no signal repetition 1 = 1 signal repetition 2 = 2 signal repetition ... 7 = 7 signal repetition
19	DIS_PHASENOISE	Phase noise unit, has to be disabled, See bug report section 7.2	1 = disable phase shift Setting 1 is mandatory
20	EN_STARTNOISE	Enables additional noise for start channel	1 = switch on noise unit
21-23	CONF_FIRE	Output configuration for pulse generator	Bit 23 = 1: negate output Fire2 Bit 22 = 1: disable output Fire2 Bit 21 = 1: disable output Fire1

2.6.2 Read registers / Output data format

ADR	Symbol	Bits	Description							
0	RES_0	32	Measurement result 1, fixed-point number with 16 integer and 16 fractional digits 2^{15} $2^0, 2^{-1}$ 2^{-16}							
1	RES_1	32	Measurement result 2, fixed-point number with 16 integer and 16 fractional digits							
2	RES_2	32	Measurement result 3, fixed-point number with 16 integer and 16 fractional digits							
3	RES_3	32	Measurement result 4, fixed-point number with 16 integer and 16 fractional digits							
4	STAT	16	15 - 13	12	11	10	9	8 - 6	5 - 3	2 - 0
			n.c.	Error short	Error open	Timeout Precounter	Timeout TDC	# of hits Ch2	# of hits Ch1	Pointer result register
5	REG_1	8	Content of highest 8 Bits of write register 1, to be used for testing the communication							

The data structure and the occupancy of the result registers depends on the operation mode and whether calibrated or non-calibrated data are stored. Several cases must be distinguished:

- Only in measurement range 1 negative results are possible.
- In measurement range 2 only positive results are possible, given as unsigned numbers.
- A non-calibrated measurement is only possible in measurement range 1.
- In measurement range 1 with calibrated data (ALU) the time intervals that have to be measured can not exceed twice the period of the calibration clock. When measuring bigger time intervals an ALU - overflow will occur and 0xFFFFFFFF is written in the appropriate result register.

a. Measurement range 1 with calibrated data (Calibrate = 1)

The results are given in multiples of the internal reference clock (= external reference clock divided by 1, 2 or 4 (DIV_CLKHS)). Calibrated data are 32 bit fixed point numbers with 16 integer bits and 16 fractional bits. Any calibrated result covers therefore 1 result register. The serial output begins with the highest bit (2^{15}) and ends with the lowest one (2^{-16}). The numbers are available in complements of 2.

$$\text{Time} = \text{RES}_X * T_{\text{ref}} * 2^{\text{ClkHSDiv}} = \text{RES}_X * T_{\text{ref}} * N, \text{ with } N = 1, 2 \text{ or } 4$$

$$\text{Time} < 2 * T_{\text{ref}} * 2^{\text{ClkHSDiv}}$$

b. Measurement range 1 without calibration (Calibrate = 0)

Non-calibrated data are of the type ‚Signed Integer‘ and are stored as a 16 bit value in the high word of the result registers. The bits of the low word are set to zero. The result is represented as number of LSB and is available in complements of 2.

$$\text{Time} = \text{RES}_X * \text{LSB} \sim \text{RES}_X * 65 \text{ ps}$$

c. Measurement range 2

In measurement range 2 the TDC-GP2 only supports calibrated measurement. The results are given in multiples of the internal reference clock (= external reference clock divided by 1, 2 or 4 (DIV_CLKHS)). Calibrated data are 32 bit fixed point numbers with 16 integer bits and 16 fractional bits. Any calibrated result covers therefore 1 result register. The serial output begins with the highest bit (2^{15}) and ends with the lowest one (2^{-16}). The numbers are available in complements of 2.

$$\text{Time} = \text{RES}_X * T_{\text{ref}} * 2^{\text{ClkHSDiv}} = \text{RES}_X * T_{\text{ref}} * N, \text{ with } N = 1, 2 \text{ or } 4$$

d. Temperature measurement

Discharge time in the same format as in c. measurement mode 2.

2.6.3 Status register

Bits	Name	Description	Values
2 – 0	Pointer result register	Pointer to the next free result register	
5 – 3	# of hits Ch 1	Number of hits registered on channel 1	
8 – 6	# of hits Ch 2	Number of hits registered on channel 2	
9	Timeout TDC	Indicates an overflow of the TDC unit	1 = overflow
10	Timeout Precounter	Indicates an overflow of the 14 bit precounter in MR 2	1 = overflow
11	Error open	Indicates an open sensor at temperature measurement	1 = open
12	Error short	Indicates a shorted sensor at temperature measurement	1 = short

3 Measurement Mode 1

3.1 General Description

- 2 stop channels referring to one start channel
- Each of typ. 50 ps RMS resolution
- LSB width typ. 65 ps
- 15 ns pulse pair resolution
- 4-fold multihit capability for each stop channel
- Measurement range 3.5 to 1.8 μs (0 to 1.8 μs between stop channels)
- Selectable rising/falling edge sensitivity for each channel
- Enable pins for powerful windowing functionality
- The possibility to arbitrarily measure all events against each other

Digital TDCs use internal propagation delays of signals through gates to measure time intervals with very high precision. Figure 5 clarifies the principal structure of such an absolute-time TDC. Intelligent circuit structures, redundant circuitry and special methods of layout on the chip make it possible to reconstruct the exact number of gates passed by the signal. The maximum possible resolution strongly depends on the maximum possible gate propagation delay on the chip.

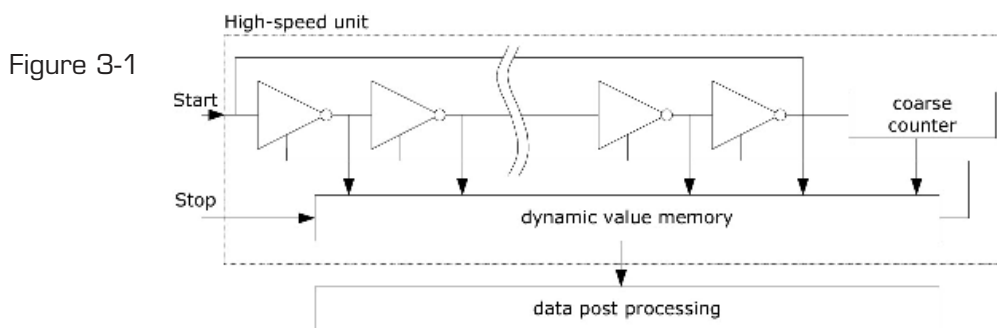

The measuring unit is actuated by a START signal and stopped by a STOP signal. Based on the position of the ring oscillator and the coarse counter the time interval between START and STOP is calculated with a 20 Bit measurement range.

The BIN size (LSB) is typically 65 ps at 3.3 V and 25 °C ambient temperature. The RMS noise is about 50 ps (0.7 LSB). The gate propagation delay times strongly depend on temperature and voltage. Usually this is solved doing a calibration. During such a calibration the TDC measures 1 and 2 periods of the reference clock.

The measurement range is limited by size of the counter:

$$t_{\text{ty}} = \text{BIN} \times 26224 \sim 1.8 \mu\text{s}$$

	Time (Condition)	Description
t _{ph}	2,5 ns (min.)	Minimum pulse width
t _{pl}	2,5 ns (min.)	Minimum pulse width
t _{ss}	3.5 ns (min) 1.8 μs (max.)	Start to Stop
t _{rr}	15 ns (typ.)	Rising edge to rising edge
t _{ff}	15 ns (typ.)	
t _{va}	560 ns uncalibrated 4.6 μs calibrated	Last hit to data valid
t _{xx}	No timing limits	
t _{yy}	1,8 μs (max)	Max. measuring range

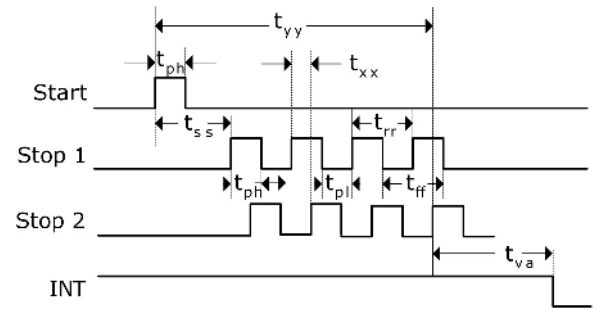

Figure 3-2

Input circuitry

Each input separately can be set to be sensitive to rising or falling edge or both edges. This is done in register 0, Bits 0 to 2. (NEG_START, NEG_STOP1, NEG_STOP2) and register 2, Bit 19&20, RFEDGE_x.

Furthermore all Start/Stop-inputs support a high active enable pin.

3.2 Measurement Flow

Figure 3-3

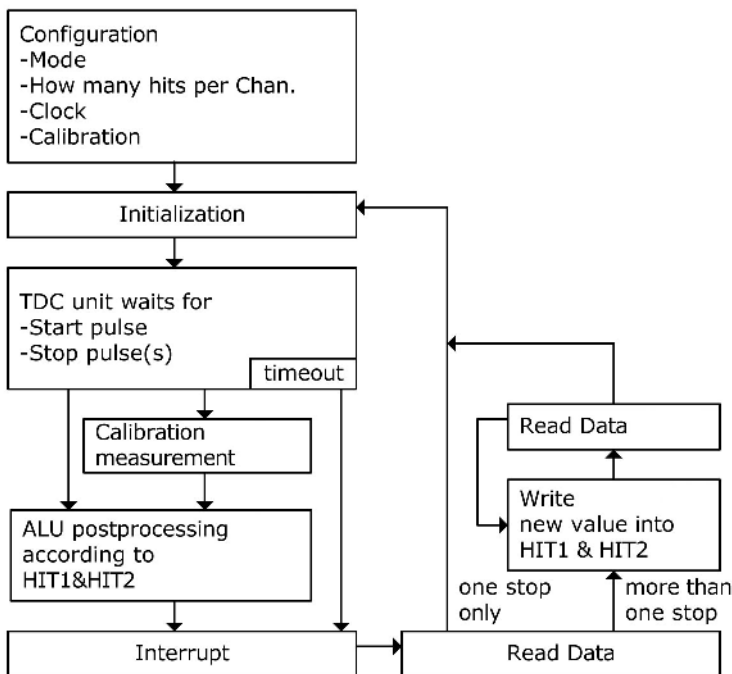

3.2.1 Configuration

At the beginning the TDC-GP2 has to be configured. The main settings for measurement range 1 are:

a. Select measurement range1

setting register 0, Bit3, MRange2 = 0.

b. Select the reference clock

(see also section 5.1)

Register 0, Bits 10&11, START_CLKHS defines the switch-on behavior of the high-speed clock. If only the 32kHz is used this is be set to „0“. If only the high-speed clock is used this is be set to „1“ (conti-

nuously on). In case both oscillators are used for current saving reasons this should be set to „2“ for ceramic oscillators and to „3“ for quartz oscillators“.

Register 0, Bits 12&13, ClkHSDiv sets an additional internal divider for the reference clock (1,2 or 4). This is important for calibrated measurements in measurement range 1 because the ALU works correctly only if $2 * T_{ref}(intern)$ is bigger than the maximum time interval to be measured. Otherwise the ALU output is 0xFFFFFFFF.

Make also sure that $2 * T_{ref}(intern) < 1.8 \mu s$ to avoid a timeout during calibration.

c. Set the number of expected hits

In register 1, Bits 8 to 10 and 11 to 13, HITIN1 and HITIN2 the user has to define the number of hits the TDC-GP2 has to wait for. A maximum of 4 on each channel is possible. The TDC-GP2 measures until the set number of hits is registered or a timeout occurs.

d. Select calibration

As the BIN size varies with temperature and voltage the TDC-GP2 ALU can internally calibrate the results. This option is switched on by setting register 0, Bit5, Calibrate = „1“. It is recommended to do this.

For the calibration the TDC measures 1 and 2 cycles of the reference clock. The two data are stored as Cal1 and Cal2.

There are two ways to update the calibration data Cal1 and Cal2:

- Separate calibration by sending opcode Start_Cal_TDC via the SPI interface
- Automatic update by setting register 0, Bit 4, DisAutoCal = „0“. In most applications this will be the preferred setting.

e. Define ALU data processing

While the TDC unit can measure up to 4 hits on each channel the user is free in his definition what the ALU shall calculate. The settings are done in register 1, Bits 16 to 19 and 20 to 23, HIT1 and HIT2. Both parameters can be set to:

0 = Start

1 = 1. Stop Ch1 9 = 1. Stop Ch2

2 = 2. Stop Ch1 A = 2. Stop Ch2

3 = 3. Stop Ch1 B = 3. Stop Ch2
 4 = 4. Stop Ch1 C = 4. Stop Ch2
 6 = Cal1 Ch1
 7 = Cal2 Ch1

Examples:

Reg1 = 0x01xxxx - 1st Stop Ch1-Start
 Reg1 = 0x2Bxxxx - 3rd Stop Ch2-2nd
 Stop Ch1
 Reg1 = 0x06xxxx - Cal1

The ALU calculates Hit1 - Hit2.

In case calibration is active the ALU does the full calibration calculation (except when reading the calibration values. In this case the ALU writes the Cal1/Cal2 raw data to the output register).

$$RES_X = \frac{(HIT1 - HIT2)}{Cal2 - Cal1}$$

Cal2 - Cal1 = gradient N = 1, 2 or 4.

$$Time = RES_X \times T_{ref} \times 2^{ClkHSDiv} = RES_X \times T_{ref} \times N$$

Figure 3-4

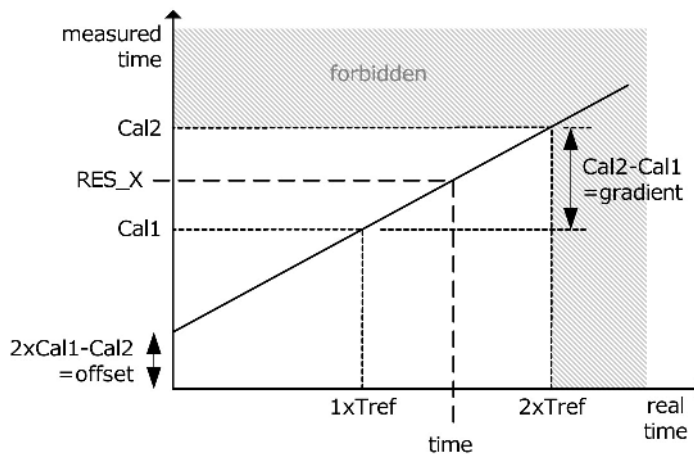

f. Select input sensitivity

In register 2, Bits 19 & 20, RFEDGE1 and RFEDGE2, the user can select whether the stop inputs are sensitive to either rising or falling edges (RFEDGE = „0“) or to both rising and falling edges (RFEDGE = „1“).

In register 0, Bits 0 to 2 the user can add an internal inverter to each input, Start, Stop1 and Stop2. With RFEDGE = „0“ this is the same as rising edge (NEG_X = „0“) or falling edge (NEG_X = „1“).

g. Interrupt behavior

The interrupt pin 8, INT can have different sources. They are selected in register 2, Bits 21 to 23, EN_INT.

EN_INT =	0	no Interrupt source
	1	ALU ready
	2	The set number of hits is there
	4	Timeout of the TDC unit

The different options are wired by OR to enable more than one source.

There are further configuration options that will be described later in this chapter.

After the configuration the user has to initialize the TDC-GP2 by sending opcode „Init“ so that the TDC accepts Start and Stop hits.

3.2.2 Measurement

After an initialization the TDC unit will start with the first pulse on the Start input. It will run until:

- the set number of hits has been seen (maximum 4 on both stop channels in MR1)
- or until a timeout occurs at the end of the measurement range (at about 1.8µs in ,MR1).

The time measurement raw data are internally stored. The number of hits can be seen from the status register, bits 3 to 8. In case calibration is active the TDC now measures one and two periods of the internal reference clock ($T_{ref} * 1, 2$ or 4). The calibration raw data Cal1 and Cal2 are also internally stored.

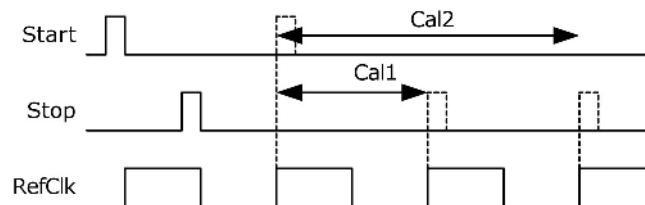

Figure 3-5

3.2.3 Data Processing

At the end of the measurement the ALU starts to process the data according to the HIT1, HIT2 settings and transfers the result to the output register. In case calibration is off the ALU transfers the 16 Bit raw data to the output register. With calibration the ALU calculates according to 3.1.1.d and transfers the 32Bit fixed point number to the output register.

The ALU can be switched off configuring HIT1=HIT2=5.

The time it takes the ALU depends on whether calibration is on or not and the supply voltage.

Table 3-1: ALU timings

	un-calibrated	calibrated
3.3 V	220 ns	2.3 μ s
2.5 V	310 ns	2.5 μ s
2.0 V	580 ns	2.8 μ s

As soon as the data is available from the output register the interrupt flag is set (assumed that the ALU interrupt is enabled, see reg 2, EN_INT). Further the load pointer of the output register is increased by 1 and points to the next free memory. The actual position of the load pointer can be seen in the status register, Bits 0 to 2.

3.2.4 Reading Data

Now the user can read the data sending the opcode 10110ADR. With the next 16 cycles (un-calibrated data) or 32 cycles (calibrated data) the TDC-GP2 will send the result, beginning with the most significant Bit (MSB).

a. Un-calibrated data format:

16 Bit Signed integer in complements of 2. 1BIN = uncalibrated gate delay is about 65ps at 5V and 25°C.

$$\text{Time} = \text{RES_X} \times 65\text{ps}$$

b. Calibrated data format:

32 Bit fixed-point number in complements of 2. Given in multiples of the reference clock.

$$\text{Time} = \text{RES_X} * T_{\text{ref}} * N, \quad N = 1, 2 \text{ or } 4$$

The measured time interval may not exceed , otherwise the ALU will go into overflow and will write the data 0xFFFFFFFF to the output register.

The configuration of the ALU allows only one hit calculation at the time. In case more than one hit has been measured it is necessary to write new commands to HIT1/HIT2 to instruct the ALU for calculating the other hits. After writing to HIT1/HIT2 it is necessary to wait for minimum 4.6 μ s (calibrated data) or 580ns (un-calibrated data) before reading or writing again to HIT1/HIT2.

Example:
configuration

```

...
write reg1=0x104400      4 hits on channel 1,
                          calculate Hit1-Start
...
Initialize
...
while(Check interrupt flag)
write reg1=0x204400      calculate Hit2-Start
wait(4.6 $\mu$ s)
write reg1=0x304400      calculate Hit3-Start
wait(4.6 $\mu$ s)
write reg1=0x404400      calculate Hit4-Start
wait(4.6 $\mu$ s)
Now all Hit data are available from registers 0 to 3.
The load pointer value is 4.
    
```

At the end the TDC-GP2 has to be initialized again to be ready for the next measurement. This is done by sending the opcode „Init“ so that the TDC accepts new Start and Stop hits.

4 Measurement Mode 2

4.1 General Description

- 1 stop channels referring to one start channel
- Typ. 50 ps RMS resolution
- LSB width typ. 65 ps
- 2 x Tref pulse pair resolution
- 3-fold multihit capability
- Measurement range 2 x Tref to 4 ms @ 4MHz
- Selectable rising/falling edge sensitivity
- Integrated programmable windowing for each single stop with 10 ns precision

Digital TDCs use internal propagation delays of signals through gates to measure time intervals with very high precision (see also measurement range 1, section 4).

In measurement range 2 the maximum time interval is extended using a pre-divider. The resolution in LSB remains unchanged by that. In this mode the high-speed unit of the TDC does not measure the whole time interval but only time intervals from START and STOP to the next rising edge of the reference clock (fine-counts). In between the fine-counts the TDC counts the number of periods of the reference clock (coarse-count).

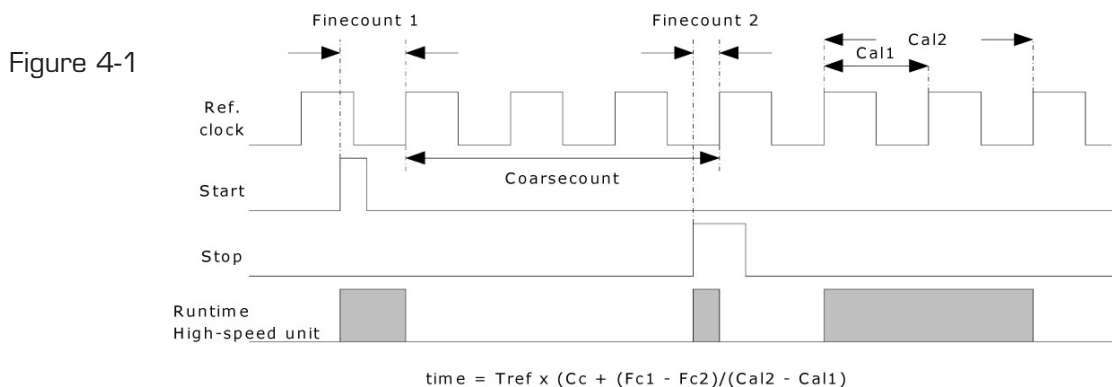

The BIN size (LSB) is typically 65 ps at 3.3 V and 25 °C ambient temperature. The RMS Noise is approx. 50 ps (0.7 LSB). The gate propagation delay times strongly depend on temperature and voltage. In measuring range 2 the result is the sum of different fine and coarse-count results. Therefore it is necessary in measuring range 2 to make a calibration. During a calibration the TDC measures 1 and 2 periods of the reference clock.

The measurement range is limited by size of the coarse counter:

$$t_{\text{max}} = T_{\text{ref}} \times 2^{14} = 4.1 \text{ms @ 4MHz}$$

The time interval between START and STOP is calculated with a 26 Bit measurement range.

Figure 4-2

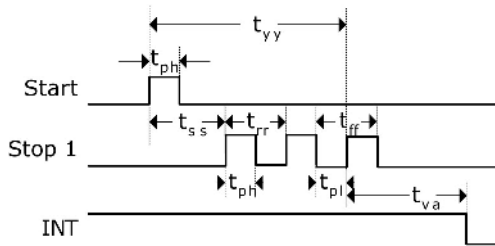

	Time (Condition)	Description
tph	2,5 ns (min.)	Minimum pulse width
tpl	2,5 ns (min.)	Minimum pulse width
tss	$2 * T_{ref}$	Start to Stop @ Dis_PhaseNoise=1
trr	$2 * T_{ref}$	Rising edge to rising edge
tff	$2 * T_{ref}$	Falling edge to falling edge
tva	4.6 μ s (max.)	ALU start to data valid
tyy	4 ms (max)	Max. measuring range

Input circuitry

Each input separately can be set to be sensitive to rising or falling edge. This is done in register O, Bits 0 to 2. (NEG_START, NEG_STOP1).

Further all Start/Stop-inputs support a high active enable pin.

Note:

In case the Start-Stop interval is less than the lower limit tzz the TDC will ignore more and more events the smaller it is. In no case there will be wrong results.

4.2 Measurement Flow

Figure 4-3

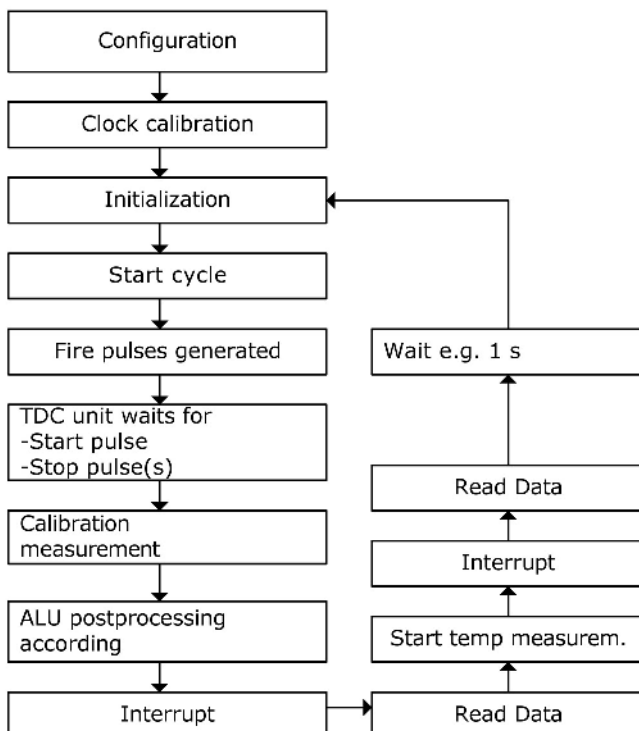

4.2.1 Configuration

At the beginning the TDC-GP2 has to be configured. The main settings for measurement range 2 are:

a. Select measurement range2

setting register O, Bit3, MRange2 = 1.

b. Select the reference clock

(see also section 5.1)

In measurement range 2 the TDC-GP2 needs the high-speed clock for the time measurement. In case of low-power applications this clock can be switched of in between measurements. The a 32.768 kHz clock is necessary for the timing control during the oscillator power-on.

Register 0, Bits 10&11, START_CLKHS defines the switch-on behavior of the high-speed clock. If only the high-speed clock is used this is to be set to „1“ (continuously on). In case both oscillators are used for current saving reasons this should be set to „2“ for ceramic oscillators and to „3“ for quartz oscillators“.

Register 0, Bits 12&13, ClkHSDiv sets an additional internal divider for the reference clock (1, 2 or 4). The choice has an influence on the minimum time interval

$$t_{\min} = 2 * T_{\text{ref}} * 2^{\text{ClkHSDiv}}$$

and the maximum time interval

$$t_{\max} = 2^{14} * T_{\text{ref}} * 2^{\text{ClkHSDiv}}$$

Further, it is necessary that

$$2 * T_{\text{ref}} * 2^{\text{ClkHSDiv}} < 1.8 \mu\text{s}.$$

Otherwise the ALU will go into an overflow during calibration and write 0xFFFFFFFF as output data.

c. Set the number of expected hits

In register 0, Bits 8 to 10, HITIN1 the user has to define the number of hits the TDC-GP2 has to wait for. A maximum of 3 on channel 1 is possible. The number HITIN1 always has to be higher by 1 than the number of expected hits. The reason is that the Start is also counted as a hit. The TDC-GP2 measures until the set number of hits is registered or a timeout occurs. register 0, Bits 11 to 13, HITIN2 have to be set to „0“.

Example:

2 stop pulses are expected:

HITIN1 = 3, HITIN2 = 0

d. Select calibration

The calibration is switched on by setting register 0, Bit 5, Calibrate = „1“. It is mandatory to do this.

For the calibration the TDC measures 1 and 2 cycles of the reference clock. The two data are stored as Cal1 and Cal2.

There are two ways to update the calibration data Cal1 and Cal2:

- Separate calibration by sending opcode Start_Cal_TDC via the SPI interface
- Automatic update by setting register 0, Bit 4, DisAutoCal = „0“. In most applications this will be the preferred setting.

e. Define ALU data processing

While the TDC unit can measure up to 3 hits the ALU can calculate only one hit at once. The settings are done in register 1, Bits 16 to 19 and 20 to 23, HIT1 and HIT2. The Start pulse is internally handled like a Stop pulse because of the special measuring method in measurement range 2.

Reg1 = 0x21xxx = Calculate 1st Stop Ch1-Start

Reg1 = 0x31xxx = Calculate 2nd Stop Ch1-Start

Reg1 = 0x41xxx = Calculate 3rd Stop Ch1-Start

The ALU calculates the time interval as:

$$RES_X = CoarseCount + \frac{(HIT1 - HIT2)}{Cal2 - Cal1}$$

$$Time = RES_X * T_{ref} * 2^{ClkHSDiv}$$

f. Select input sensitivity

In register 2, Bits 19 & 20, RFEDGE1 and RFEDGE2, the user can select whether the stop inputs are sensitive to either rising or falling edges (RFEDGE = „0“) or to both rising and falling edges (RFEDGE = „1“). In register 0, Bits 0 to 2 the user can add an internal inverter to each input, Start, Stop1 and Stop2. With RFEDGE = „0“ this is the same as rising edge (NEG_X = „0“) or falling edge (NEG_X = „1“).

g. Interrupt behavior

The INT pin can have various sources, to be selected in register 2, Bits 21 to 23, EN_INT.

EN_INT =	0	no Interrupt source
	1	ALU ready
	2	The set number of hits is there
	4	Timeout of the TDC unit

The different options are wired by OR.

After the configuration the user has to initialize the TDC-GP2 by sending opcode „Init“ so that the TDC accepts Start and Stop hits.

4.2.2 Measurement

After an initialization the TDC unit will start with the first pulse on the Start input. It will run until:

- the set number of hits has been seen (maximum 3 on channel 1 in measurement range 2)
- or until a timeout occurs. The timeout can be programmed in multiples of the reference clock setting Reg 3, Bits 19&20, SEL_TIMO_MR2. At 4 MHz the values are:

SEL_TIMO_MR2 (@ 4 MHz, ClkHSDiv = 0)

= 0	= 64 μ s
= 1	= 256 μ s
= 2	= 1024 μ s
= 3	= 4096 μ s

At the end of the time measurement the TDC measures 2 periods of the reference clock for calibration.

4.2.3 Data processing

At the end of the measurement the ALU starts to process the data according to the HIT1, HIT2 settings and transfers the result to the output register. The ALU calculates according to 4.1.2.e and transfers the 32Bit fixed point number to the output register.

The time it takes the ALU depends on the supply voltage:

Table 4-1: ALU timings

	calibrated
3.3 V	2.3 μ s
2.5 V	2.8 μ s
2.0 V	3.1 μ s

As soon as the data is available from the output register the interrupt flag is set (assumed that the ALU interrupt is enabled, see reg 2, EN_INT). Further the load pointer of the output register is increased by 1 and points to the next free memory. The actual position of the load pointer can be seen in the status register, Bits 0 to 2.

4.2.4 Reading Data

Now the user can read the data sending the opcode 10110ADR. With the next 32 cycles (calibrated data) the TDC-GP2 will send the result, beginning with the main significant Bit (MSB).

The 32 Bit fixed-point number in complements of 2 represent the time interval in multiples of the reference clock.

$$\text{Time} = \text{RES_X} * T_{\text{ref}} * 2^{\text{ClkHSDiv}}$$

The configuration of the ALU allows only one hit calculation at the time. In case more than one hit has been measured it is necessary to write new commands to HIT1/HIT2 to instruct the ALU for calculating the other hits. After writing to HIT1/HIT2 it is necessary to wait for minimum 4.6µs (calibrated data) or 580ns (un-calibrated data) before reading or writing again to HIT1/HIT2.

Example:

configuration

...

write reg1=0x214400 3 hits on channel 1, calculate Hit1-Start

...

Initialize

...

while(Check interrupt flag)

write reg1=0x314400 calculate Hit2-Start

wait(4.6µs)

write reg1=0x414400 calculate Hit3-Start

wait(4.6µs)

Now all hit data are available from registers 0 to 2. The load pointer value is 3.

At the end the TDC-GP2 has to be initialized again to be ready for the next measurement. This is done by sending the opcode „Init“ so that the TDC accepts new Start and Stop hits.

4.3 Stop Masking

The TDC-GP2 can set time-based masking windows for each of the 3 hits on Stop1 input when no hits are accepted. The masking refers to the start event and has an accuracy of less than 10 ns. The internal enable unit is connected to the external enable pin by a logical AND. The external enable pin must be set to “1” to use the internal masking unit. The configuration settings are made in registers 2 to 4, DELVAL1, DELVAL2 and DELVAL3:

- DELVAL1 ... DELVAL3 are fixed point numbers with 14 bit integer and 5 bit fractional digits, in multiples of the internal reference clock

$$\text{Delay}_{\min} = \text{DELVALX} / 2^5 * T_{\text{ref}} * 2^{\text{ClkHSDiv}}$$

- The minimum mask size is 3 clock cycles
- The mask values must have an ascending order. Each mask value must be 3 clock cycles bigger than the previous value

It is mandatory that if not all registers are used the mask values that are not required are set to “0”. When all DELVAL registers are set to 0, the complete unit is disabled.

Example:

4 Mhz reference, ClkHSDiv = 1

DELVAL1 = 0x3200 1st Stop not accepted before 200 μ s after Start
 $(128000/32 * 250\text{ns} * 2^1 = 200 \mu\text{s})$

DELVAL2 = 0x3300 2nd Stop not accepted before 204 μ s after Start
 $(13056/32 * 250\text{ns} * 2^1 = 204 \mu\text{s})$

DELVAL3 = 0x3400 3rd Stop not accepted before 208 μ s after Start
 $(13312/32 * 250\text{ns} * 2^1 = 208 \mu\text{s})$



5 Details and Special Functions

5.1 Oscillator

The TDC-GP2 uses up to 2 clock signals depending on the operating mode:

- High-speed clock, typically 4 MHz, for calibration and as a predivider for the TDC measuring unit in measurement range 2
- 32 kHz clock signal used for internal timer functions.

5.1.1 High-Speed Oscillator

Generally the TDC-GP2 needs a 2 to 8 MHz high-speed clock for calibration. Operating in measurement range 2 the TDC-GP2 needs the high-speed clock signal also as a part of the time measuring unit. The oscillator takes an average current of 260 μA when running all the time.

Because it is needed only during the time measurement the TDC-GP2 has the capability to control the on-time by itself. The high-speed clock can be switched on automatically with a INIT opcode only for the period of time measurement. An additional delay cares for the settling time of the oscillator.

The settings are done in register 0, Bits 10 & 11, START_CLKHS:

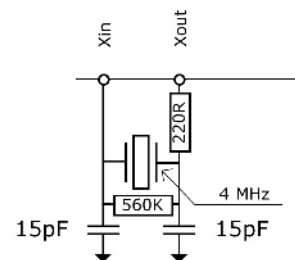

Figure 5-1

- START_CLKHS = 0 Oscillator off
- = 1 Oscillator on
- = 2 The measurement is started with 640 μs delay.
- = 3 same as '2', but with 1280 μs delay

The programmable delay guarantees that the oscillator has settled before the measurement starts. For ceramic resonators 640 μs will be sufficient.

Note:

Notice the Bug report in section 7 when using Start_CLKHS with quartz oscillators. By this measure the average current consumption can be drastically reduced.

Example:

At one ToF measurement in an ultrasonic flowmeter (forth/back) per second the high-speed oscillator is active only for about 2 ms. The average current consumption is $260 \mu\text{As} * 2 \text{ ms} = 0.52 \mu\text{A}$.

5.1.2 32.768 kHz Oscillator

The TDC-GP2 needs a 32.768 kHz reference for the start-up control of the high-speed clock and the clock calibration. It therefore offers a an integrated driver:

There is no need for the 32.768 kHz clock if the high speed clock is permanently running (START_CLKSHS = 1) and the high speed clock calibration is not used (e.g. in case of a quartz oscillator).

The 32.768 kHz oscillator is permanently running and has a current consumption of about 4.5 μ A at 3.6 V. It is also possible to provide an external low-frequency rectangular clock at the CLK32Out pin (3.6 V max.). This signal could be generated by an external microprocessor. It will reduce the current consumption down to 1.2 μ A. For this reason the 32 kHz oscillator should only be used if no external low-current 32.768 kHz clock is available. The settling time of this oscillator is about 2 s.

The external circuit is necessary only if the 32.768 kHz oscillator is used. Otherwise CLK32In has to be connected to GND.

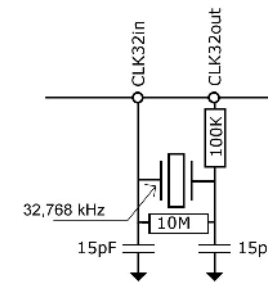

Figure 5-2

5.1.3 Calibrating a Ceramic High-speed Oscillator

Using a ceramic oscillator for the 2 to 8 MHz clock will be attractive because it is of low cost and has a fast settling time. Unfortunately it has a poor tolerance of 0.3 to 0.5 % and shows a temperature drift. For this reason the TDC-GP2 allows to execute a calibration measurement that allows to compensate this behavior. This measurement is based on the very precise 32.768 kHz clock. The TDC-GP2 generates start/stop pulses from the 32.768 kHz and measures this time interval with its TDC unit. The result is stored in the result register and the interrupt flag is set. The frequency error of the ceramic resonator can be calculated by the microprocessor. The calibration is configured by setting register 0, CALRES# and is started with „START_Cal_Resonator“ - instruction by the microprocessor.

The time interval to be measured is set by CALRES# which defines the number of periods of the 32.768kHz clock:

CALRES#	= 0	2 periods = 61.035 μ s
	= 1	4 periods = 122.07 μ s

$$= 2 \quad 8 \text{ periods} = 244.14 \mu\text{s}$$

$$= 3 \quad 16 \text{ periods} = 488.281 \mu\text{s}$$

The results is given in multiples of the high-speed clock and (divided by 1, 2 or 4 (DIV_CLKHS)) as 32 bit fixed point numbers with 16 integer bits and 16 fractional bits.

The microcontroller can compare this measured value to the theoretical value and calculate the correction factor RES_X/RES_{theor} .

Example:

The system shall work with a 4 MHz resonator. With $CLKHSDIV=0$ and $CALRES\#=1$ the theoretical result is $122.0703125 \mu\text{s}/250\text{ns} = 488.28125$ ($RES_0 = 0x01E84800$). If the ceramic resonator in use is not exactly at 4MHz but only 3.98MHz the calibration measurement will show 485,83984375 ($RES_0 = 1E5D700$). The correction factor for the microcontroller is 1.005.

Note:

During clock calibration the start input has to be enabled.

5.1.4 How to use Clock Calibration

a. Application

This option is dedicated especially to ultrasonic flow and heat meters. In those applications the use of ceramic oscillators shows two main advantages: lower cost and less current consumption. Mainly because of the short oscillation start up time of the ceramic oscillator the operating current can be reduced by several μA . Referring to 10 years of operation this saves several 100 mAh in battery capacitance. There is no negative effect on the resolution when using this option the correct way.

b. Jitter of the 32 kHz clock and consequences

The 32 kHz clock is very precise in frequency with only a few ppm error. However the phase jitter is about 3 to 5 ns peak-peak. For this reason also a calibration measurement (Start_Cal_Resonator) has this error. When multiplying a measurement result with the calibration result, the jitter of the calibration is transferred to the result by the ratio calibration measurement time (see CALRES#) to measurement time. Using a permanently updated calibration value will add a considerable jitter to the measurement result.

c. Application of this option in ultrasonic flow meters

A measurement result is always made of two single time-of-flight measurements in ultrasonic flow meters, with and against the flow direction. The difference between those measurements is a measure for the flow. To avoid an influence of the calibration jitter on this measurement result it is necessary only to use the same calibration for both ToF measurements. Following this the difference between the two ToF measurements will be free of the jitter of the clock calibration measurement. The clock can be calibrated only between measurements that are not directly subtracted from each other.

5.2 Fire-pulse Generator

5.2.1 General Description

The fire-pulse generator generates a sequence of pulses which is highly programmable in frequency, phase and number of pulses. The high-speed oscillator frequency divided by the factor selected for ClkHSDiv is used as the basic frequency. This frequency is internally doubled and can freely be divided by a factor of 2 to 15. It is possible to generate 1 to 15 pulses. For each pulse the phase can be adjusted per register configuration. The fire-pulse generator is activated by sending opcode Start_Cycle.

The fire-pulse generator provides 2 outputs, Fire1 and Fire2. The driver strength of each output is 48mA @5V. These 2 outputs can be paralleled to increase the driver strength up to 96 mA. Furthermore Fire2 output signal can be inverted to double the signal amplitude. The outputs can be set individually high-Z.

The fire-pulse generator allows to generate and send pulse sequences multiple times for use in a quasi "sing-around" method. Using this feature the received pulse sequence is fed into TDC-GP2 Fire_In input. It is digitally amplified and directly forwarded to the output buffer for an immediate re-emittance without any clock delay.

Note: When the fire pulse generator is use it is mandatory to send a start pulse.

5.2.2 Configuration

Number of pulses:

FIRE# = 0	Switch off fire-pulse generator
1	1 pulse
2	2 pulses
...	...
15	15 pulses

Phase:

The phase of each pulse can be defined in register 5, Bits 0 to 15, PHASE_FIRE. „0“ stands for HIGH-LOW and „1“ for LOW-HIGH. The pulse sequence begins with the LSB and ends with the MSB

Example:
 Fire# = 7, PHASE_FIRE = 0x0055

1 0 1 0 1 0 1 0 0 0 0 0 0 0 0

Fire-pulse frequency:

The input signal fireclk1 for the fire pulse generator is derived from the high speed clock CLKHS and the selected value for the high speed clock divider CLKHS_DIV.

Figure 5-3

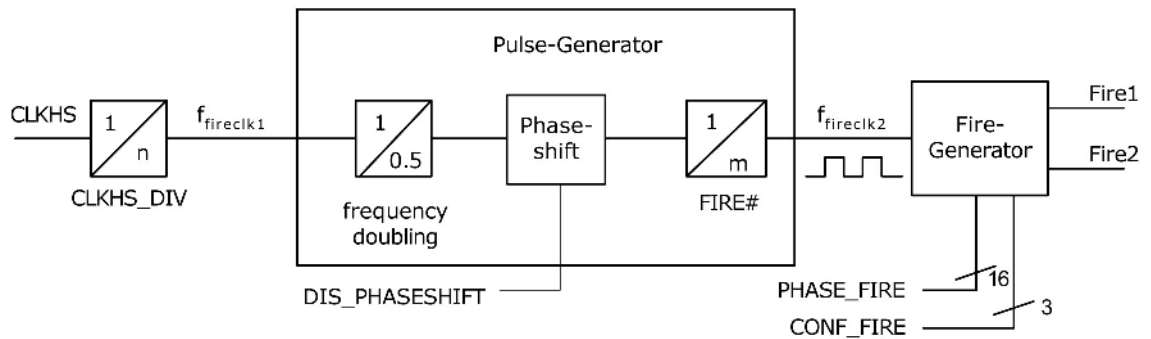

This Signal is internally doubled and divided by DIV_FIRE.

DIV_FIRE =	0	not permitted
	1	divided by 2
	2	divided by 3

	15	divided by 16

Register 5, Bit 19, DIS_PHASESHIFT activates the phase shift, which introduces additional noise to improve statistical behaviour when averaging.

DIS_PHASESHIFT = 0 Phase shift on

$$f_{\text{fireclk2}} = f_{\text{fireclk1}} \times \frac{2}{\text{DIV_FIRE} + 1}$$

DIS_PHASESHIFT = 1 Phase shift off

fireclk2 is used as reference signal for the Fire1 / Fire2 - signal which is emitted by the output buffers Fire1 / Fire 2 of the fire pulse generator.

Figure 5-4

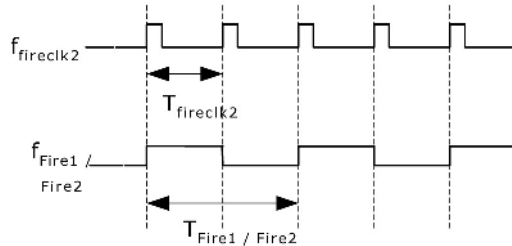

As shown in Figure 16 at least 2 clock periods T_{fireclk2} are required to send one Fire_Pulse. One for the high phase and one for the low phase of the Fire1/Fire2 output signal.

Example:

CLKHS = 4 MHz, CLKHS_DIV = 1, DIV_FIRE = 1

$$f_{\text{fireclk2}} = f_{\text{fireclk1}} \times \frac{2}{\text{DIV_FIRE} + 1} = 2 \text{ MHz}$$

Max. frequency of the Fire1 / Fire2 output signal:

$$f_{\text{Fire1/Fire2}} = \frac{1}{2} \times f_{\text{fireclk2}} = 1 \text{ MHz}$$

Driver outputs:

The output drivers are configured in register 5, Bits 21 to 23, CONF_FIRE:

Bit 23 = 1 Inverted output on FIRE2

Bit 22 = 1 FIRE2 disabled (High-Z)

Bit 21 = 2 FIRE1 disabled (High-Z)

Pulse-burst repetition (quasi sing-around):

In register 5, Bits 16 to 18, REPEAT_FIRE the number of repetitions of the pulse sequence is defined.

REPEAT_FIRE = 0 no repetition

 = 1 1 repetition

 = 7 7 repetitions

Only the number of pulses set under FIRE# will be repeated. With a period of 5 μs without a pulse the TDC-GP2 detects the end of a pulse sequence.

Note:

It is strongly recommend that the summarized time of flight of the up to 7 repetitions does not exceed the measurement range of the GP2!!!

5.3 Temperature Measurement

Especially for heat meter applications the TDC-GP2 has a PICO STRAIN based temperature measuring unit that offers high resolution and very low current consumption.

The measurement is based on measuring discharge times. Therefore a capacitor is discharged alternately through the sense resistors and the reference resistors.

Figure 5-5

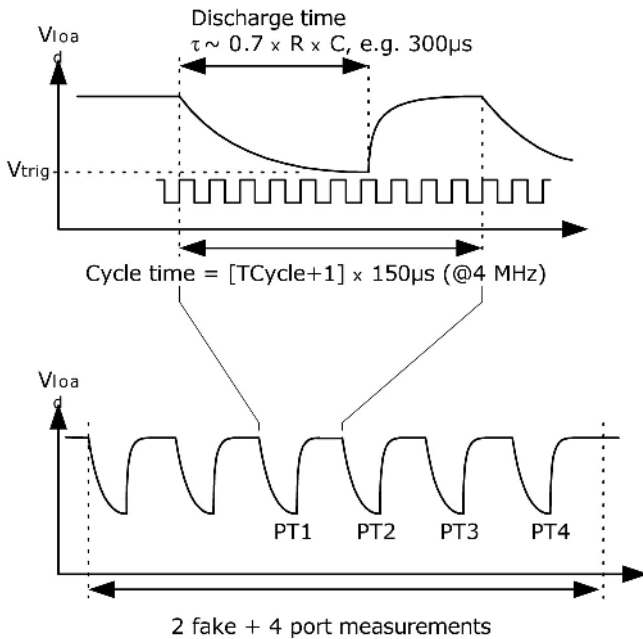
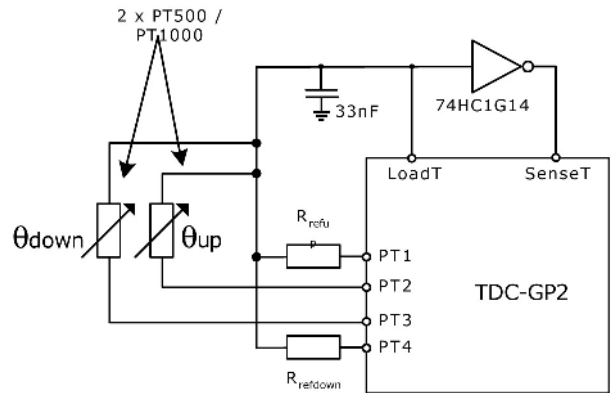

Figure 5-6



The unit has 4 resistor ports with the following function:

- PT1 reference resistor lower temperature
- PT2 sense resistor lower temperature
- PT3 sense resistor higher temperature
- PT4 reference resistor higher temperature

The temperature sensor should have a minimum resistance of 500 Ohm. The TDC-GP2 measures the discharge times of the RC-networks made of each resistor and the capacitor.

The precision of the temperature measurement is about 0.004°C several times better than needed for heat meters.

The temperature measurement is fully automated. It is triggered by the µC sending the opcode „Start_Temp“. The TDC-GP2 controls the 4 measurements by itself. After the 4 measurements have finished the interrupt flag is set. The four data are found in registers 0 to 3.

From Res_2/RES_1 and RES_3/RES_4 the microcontroller can calculate the ratio Rtemp/Rref. By means of a look-up table it can calculate the temperature for the special type of sensor in use.

It is not possible with TDC-GP2 to use 4-wire temperature sensors.

Configuration

Register 0, Bit 8, Tcycle sets the cycle time for the temperature measurement.

Tcycle = 0 128 μ s cycle time @ 4MHz

Tcycle = 1 512 μ s cycle time @ 4MHz

Register 0, Bit9, Port# sets the number of ports that will be used.

Port# = 0 2 ports = 1 sensor

Port# = 1 4 ports = 2 sensors

Register 0, Bit 7, Fake# sets the number of dummy measurements at the beginning of a temperature measurement. This is necessary to overcome mechanical effects of the load capacitor.

Fake# = 0 2 dummy measurements

Fake# = 1 8 dummy measurements

A full temperature measurement last for
 $2 \times (\# \text{ of ports}) + (\# \text{ of fakes})$ cycles.

Recommended Capacitor Values

The discharge time should be about 150 μ s. Therefore the capacitor should have the following value:

PT500: 220 nF

PT1000: 100 nF

Please set Tcycle = 1 to avoid Timeout Error.

Recommended Capacitor Type

To get accurate results we recommend capacitor types with very low dC/dU. We recommend:

CfCap Series from Tayo Yuden

For heatmeter application please do not use X7R or similar capacitors.

Current consumption

By means of the TDC technology the temperature measurement needs an extremely low current, much less than an A/D converter does.

A full temperature measurement with 2 sensors, 2 references and PT1000 sensor type, including all calculations takes less than 2.5µAs. With one temperature measurement in 30 seconds (typical for heatmeters) the average current consumption is 0.08 µA only. This is about 50 times less than other solutions. A PT500 sensor doubles the current.

Note: During temperature measurement the start input has to be enabled.

Error detection

Additionally the temperature unit checks the plausibility of the results. It is able to detect a short circuit of the sensor or an open sensor. The TDC-GP2 provides in the relevant output register an error code instead of a measurement value.

1. Short circuit: equivalent to a very short time interval ($< 8 \times T_{ref} = 2 \mu s @ 4 MHz$). The TDC-GP2 writes a 0x0 to the output register of the shorted sensor.
2. Broken sensor: equivalent to no stop signal or timeout. The TDC-GP2 writes a 0xFFFFFFFF into the output register of the open sensor.

Table 5-1: Analog specification

Parameter	Value (typ.)	Unit
Resolution RMS	16.0	Bit
SNR	96	dB
Absolut Gain-Error	0,1	%
Gain-Drift vs. Vio	0,08	%/V
Gain-Drift vs. Temp	0,0008	%/C
Uncalibrated Offset	<0.01	%
Offset Drift vs. Temp	<0,2	ppm/C
PSRR	>100	dB

Condition: Vio = Vcc = 3.3 V, PT1000, 150nF charging capacitor

5.4 SPI-interface

The serial interface is compatible with the 4-wire SPI standard. It needs the SerialSelectNot (SSN) and can not operated as 3-wire interface.

SSN - Slave Select
 SCK - SPI Clock
 SI - SPI Data In
 SO - SPI Data Out

The TDC-GP2 does only support the following SPI mode:

Clock Phase Bit =1
 Clock Polarity Bit =0

The timings are shown in figures section 2.2. It is mandatory to set the SSN – line to High-state for at least 50ns between each Read-/Write sequence.

SSN as Reset

The SerialSelectNot (SSN) line is the HIGH-active reset for the serial interface. After SSN is set to LOW different operations can be addressed, not depending on the status of the interface before the reset.

OPCodes

MSB							LSB	Description	
1	0	0	0	0	ADR2	ADR1	ADRO	Write into address ADR	followed by 24 bit data
1	0	1	1	0	ADR2	ADR1	ADRO	Read from address ADR	
0	1	1	1	0	0	0	0	Init	
0	1	0	1	0	0	0	0	Power On Reset	
0	0	0	0	0	0	0	1	Start_Cycle	
0	0	0	0	0	0	1	0	Start_Temp	
0	0	0	0	0	0	1	1	Start_Cal_Resonator	
0	0	0	0	0	1	0	0	Start_Cal_TDC	

The transfer starts with the MSB and is finished sending the LSB. After sending the last Bit TDC-GP2 transfers the data into the target register or executes the command. It is not possible to do incremental writing. Each register must be addressed separately.

When reading from the chip it is necessary to send the opcode first, too. With the first positive edge of the clock following the opcode the TDC-GP2 sends the MSB of the addressed register to SO output. Each positive edge transfers the next lower Bit to the output.

5.5 Fast Initialization

In measurement range 1 the TDC-GP2 offers the possibility of a fast initialization. Activated by setting register 1, Bit 15, EN_FAST_INIT = „1“ the interrupt flag automatically initializes the TDC. So the TDC is already prepared for the next measurement while the data can be read out. This mode is for highest speed applications only. It is most reasonable for un-calibrated measurements with only one stop.

5.6 Noise Unit

In case the user wants to improve the measuring results by averaging it is necessary that the values do not always display exactly the same time difference. Instead the user should provide some ‚noise‘ so that different quantization steps of the characteristic curve of the TDC are involved. This can not happen with very constant time differences. One would constantly hit the same LSB.

The noise unit enables the use of weighted averaging even for constant time differences. The noise unit adds a random offset to the start. It is dedicated to applications where the TDC gets a dummy start and measures the time difference between STOP1 and STOP2 (e.g. laser range finders).

The noise unit is switched on by setting register 5, Bit 20, EN_STARTNOISE = „1“



6 Applications

6.1 Ultrasonic Heatmeter

6.1.1 General Description

The TDC-GP2 is perfectly suited for low-cost ultrasonic heatmeter designs. Thanks to the implemented functionality, including precision temperature measurement, fire pulse generation, windowing and clock calibration it is sufficient to add a simple microprocessor (without A/D converter) and a transducer dependant driver and receiver. The extremely low current consumption guarantees the necessary long battery lifetime in such applications.

The measurement is fairly automated by the TDC-GP2. The microprocessor just sends a start command. The TDC then fires the transducers and measures the time of flight. It calibrates the results and provides them to the microprocessor.

Figure 6-1

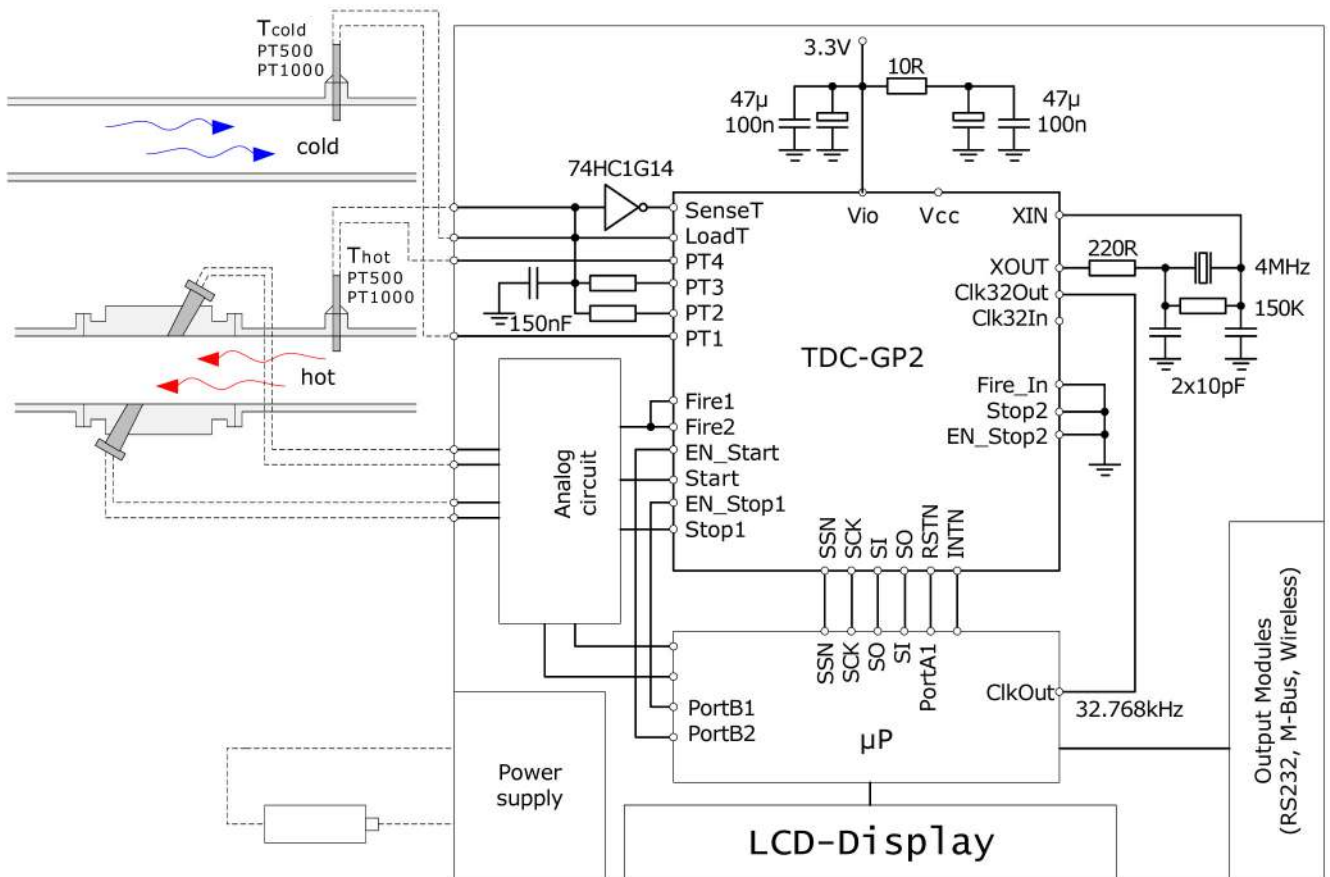

6.1.2 Configuration

A typical configuration could look like:

```
Register 0:  0x338AE8  Fire# = 3, DIV_FIRE=3, CalRes# = 8, ClkHSDiv = 0,START_CLKHS = 2,
              Port# = 4, TCycle = 0, Fake# = 2, SelClkT = 1, Calibrate = 1,
              DisAutoCal = 0, MRange2 = 1, NEG_STOP2 = 1, NEG_STOP1 = 1,
              NEG_START = 1

Register 1:  0x214400  HIT2 = 1, HIT1 = 2, EN_FASTINT = 0, HITIN2 = 0, HITIN1 = 4
Register 2:  0xE03200  TimeOut =1, Endhits = 1, ALU = 1, REFEDGE2 = 0, REFEDGE1 = 0
              DELVAL1 = 400
Register 3:  0x083300  EN_ERR_VAL = 0, SEL_TIMO_MB2 = 1DELVAL2 = 408
Register 4:  0x203400  DELVAL3 = 416
Register 5:  0x080000  CONF_FIRE = 0, EN_STARTNOISE = 0, DIS_Phasenoise = 1,
              REPEAT_FIRE = 0, PHASE_FIRE = 0
```

- All inputs are set to rising edges
- Measurement range 2 is used with Auto-calibration.
- The temperature measurement uses the high-speed clock with 128µs cycle time and 2 fake measurements on 4 ports (2 sensors, for cold and hot water)
- The high-speed clock is switched on only for the time measurement with 640µs delay
- The 4 MHz high-speed clock is used without a divider
- The 4 MHz clock calibration is based on 8 periods of the 32.768 kHz clock (244.14 µs)
- For the fire-pulse generation the 4 MHz is internally doubled and the divided by 4 making 1 MHz. The generator sends 3 pulses
- The first stop is accepted after 100 µs, the second one after 102 µs and the third one after 104 µs.
- The TDC is set to measure 3 hits on STOP1.
- The ALU is set to calculate first Hit1 – Start
- All interrupt options are activated, timeout will be given after 1024 µs
- Phase-shifting is disabled

6.1.3 Measurement Flow

Power-on reset:

Send SO = 0x50

Configuration:

Send SO = 0x80338AE8

Send SO = 0x82114000

Send SO = 0x82E03200

Send SO = 0x83083300

Send SO = 0x84203400

Send SO = 0x85080000

Calibrate Clock:

Send SO = 0x03 Start_Cal_Resonator

Check-loop INTN = 0?

Send SO = 0xB0, Read SI = RES_0

Correction factor = $488.28125/RES_0$

Measurement loop:

Temperature measurement every 30 seconds:

Send SO = 0x02 Start_Temp

Check-loop INTN = 0?

Send SO = 0xB4, Read SI = STAT

STAT&0x1E00 > 0: -> Error routine

Send SO = 0xB0, Read SI = RES_0

Send SO = 0xB1, Read SI = RES_1

Send SO = 0xB2, Read SI = RES_2

Send SO = 0xB3, Read SI = RES_3

$R_{hot}/R_{ref} = RES_0/RES_1$

$R_{cold}/R_{ref} = RES_3/RES_2$

Go to look-up table to get the temperatures

Time-of-flight measurement every half second:

Send SO = 0x70 Initialize TDC

Send SO = 0x01 Start_Cycle triggers fire-pulse generator.

Check-loop INTN = 0?

Send SO = 0xB4, Read SI = STAT

STAT&0x0600 > 0: -> Error routine

Send SO = 0x81314000 calculate HIT2-Start

Wait for 4.6µs (ALU time)

Send SO = 0x81414000 calculate HIT3-Start

Wait for 4.6µs (ALU time)

Send SO = 0xB0, Read SI = RES_0

Send SO = 0xB1, Read SI = RES_1

Send SO = 0xB2, Read SI = RES_2

µP can now start the data post-processing and calculate the flow and the heat.

6.1.4 Current consumption

a. Time measurement

32.768kHz: are provided by the μP : $< 1.3 \mu\text{A}$

4 MHz: $0 \mu\text{A}$ in power down, $270 \mu\text{A}$ when active

TDC: $< 150 \text{ nA}$ if not active, 15 mA during active time of the high-speed unit

With 2 measurements per second (forth and back flow) the total consumption is $< 3 \mu\text{A}$.

b. Temperature measurement

A full measurement over all four ports takes less than $2.5 \mu\text{As}$ current. Typically the temperature is measured once in 30 seconds. The average current then is about $0.085 \mu\text{A}$. This is about 50 times less than with solutions without a TDC.

c. Quiescent current

Thanks to the current optimized 0.35μ technology the quiescent current is less than 150 nA typ.

d. Total system current

The complete current for the measuring unit (TDC, analog part, Transducer) will depend on the analog circuit part. It will be in the range of 4 to $6 \mu\text{A}$.

With a low-power μP (e.g. MSP430 series from TI) the average current consumption of the total device might be in the range of 11 to $16 \mu\text{A}$.

It is possible to operate the system from a lithium-thionylchloride AA cell for 10 years without changing the battery. At 6 years runtime it maybe even possible to work with a low-cost 3V CR2450 coin cell battery.

7 Miscellaneous

7.1 Bug Report

7.1.1 Quartz Oscillator Start Up time

Bug:	<p>When using a quartz resonator for the oscillator the oscillation start up time is about 3 ms even with an optimized circuit. The TDC-GP2's automatic on-time control for the high speed clock is based on 640 μs or 1280 μs delay without any activity. In case of a quartz resonator this delay is too short and will cause malfunction.</p>
Corrective:	<p>There are several options to deal with.</p> <p>1.Oscillator permanently on The possibility of switching off the high speed oscillator is added only for current saving. This oscillator needs about 270 μA when running continuously. In all application without attention to current consumption we recommend to run the high speed oscillator continuously (START_CLKHS=1).</p> <p>2.Ceramic Resonator With a ceramic resonator the oscillation start up time is about 200 μs. There is no problem with TDC-GP2's internal delays. We recommend the use of ceramic resonators in all applications targeting ratio measurements (like ultrasonic flow metering).</p> <p>In all applications that need a quartz resonator and the switch-off functionality we recommend the following measures:</p> <p>3.Lower Clock Frequency at CLK32In A clock with lower frequency increases the internal timer delays. In this case we recommend about 4 kHz. The timer delay is increased to 10 ms then. This is enough for a save oscillation start up time of the quartz.</p> <p>4.Start/Stop Oscillator by Software Writing a „1“ or „0“ into Start_CLKHS starts or stops the oscillator by software. This way a μP can start the oscillator by command and then after 10 ms can send a measurement opcode like START_CYCLE. At the end of the measurement the μP has to switch off the oscillator by a further command.</p>

7.1.2 DIS_PHASENOISE

Bug:	<p>The TDC-GP2 offers a Phase-Noise function that decouples the calibration clock from the fire pulse generator. This option was implemented to provide the necessary statistics for averaging in case the user is looking for a resolution much better than 1 LSB (about 65 ps) and has a a very strong coupling between the start and the reference clock.</p> <p>Because of a design bug the phase noise unit might fail in case of distortions on the power supply. This is relevant only in measurement range 2.</p>
Corrective:	<p>The phase noise unit has to be switched off by setting DIS_PHASE_NOISE = 1. In case the start is already asynchronous to the referenceclock this has no effect on the capability of averaging.</p>

7.2 Last Changes

05.10.2006	3.2.1b&c, 5.1.3, DIS_PHASENOISE=1 required
27.11.2006	5.2.2 Additional corrections
	3.2.1 Corrections Example
01.02.2007	5.3 Additional corrections for temp. measurement
26.05.2010	Various smaller error fixes. General layout change



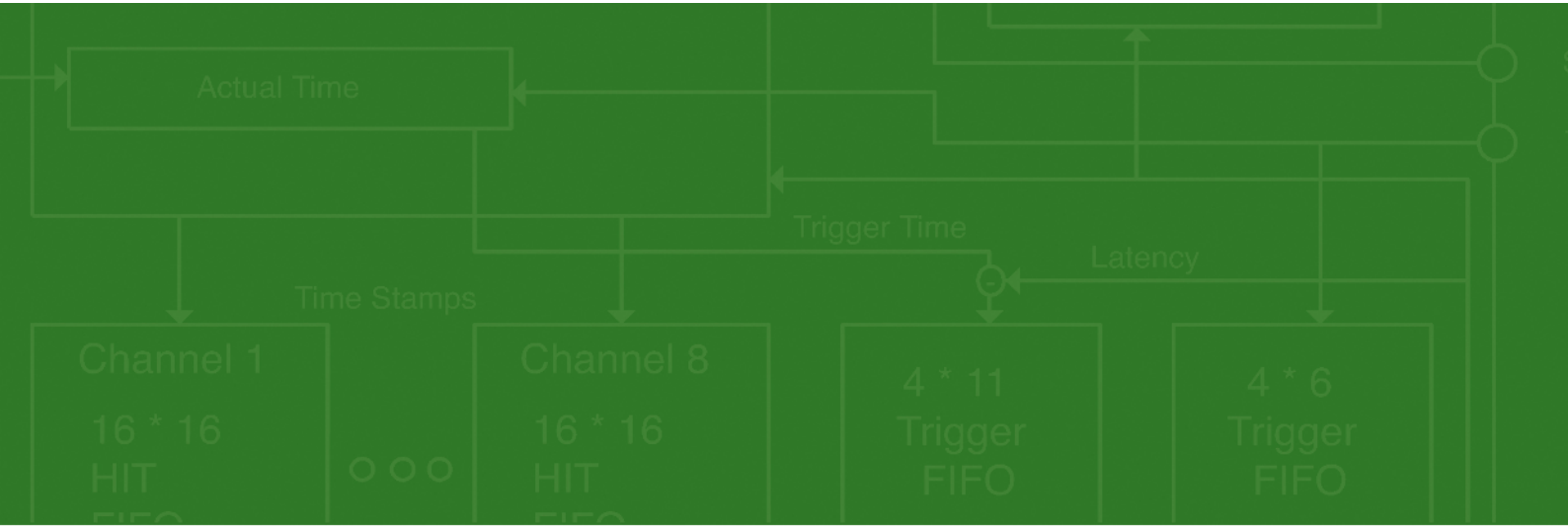

acam-messelectronic gmbh
Am Hasenbiel 27
76297 Stutensee-Blankenloch
Germany / Allemagne
ph. +49 7244 7419 - 0
fax +49 7244 7419 - 29
e-mail: support@acam.de
www.acam.de