

**Guardian
WIRE-TO-BOARD
INTERCONNECT SYSTEMS**

Receptacle Cable Assy

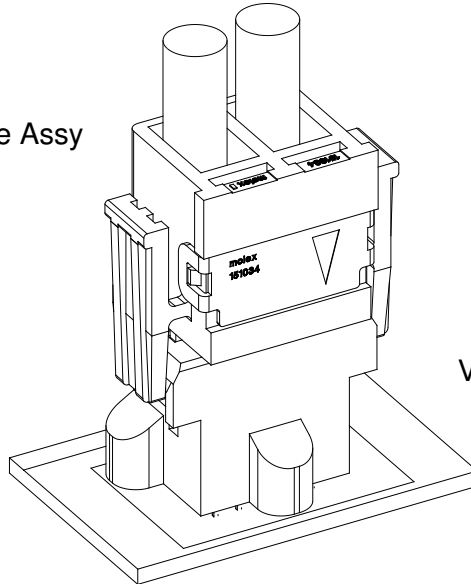

Vertical Plug

Receptacle Cable Assy

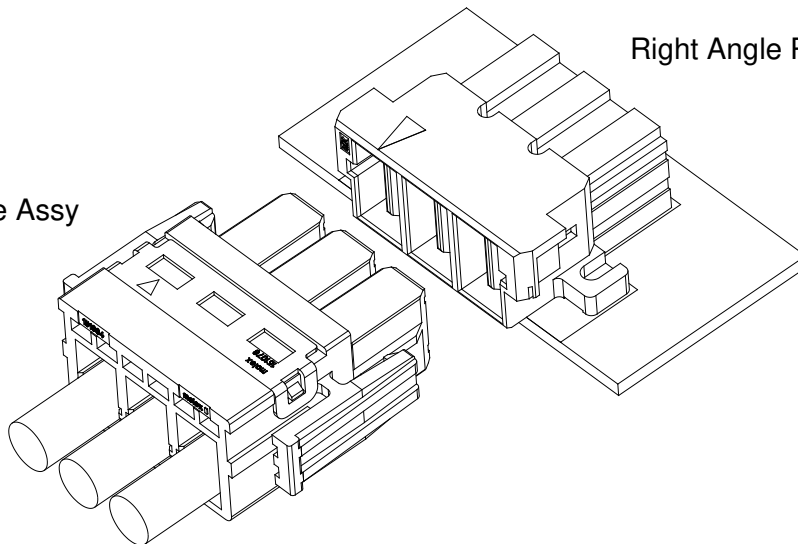

Right Angle Plug

<p>REVISION: A</p>	<p>ECR/ECN INFORMATION: EC No: S2016-0814 DATE: 2016 / 03 / 09</p>	<p>TITLE: GUARDIAN WIRE-TO-BOARD INTERCONNECT SYSTEMS</p>	<p>SHEET No. 1 of 12</p>
<p>DOCUMENT NUMBER: PS-151053-0000</p>	<p>CREATED / REVISED BY: CGOH/ 2016/03/09</p>	<p>CHECKED BY: EANG 2016/03/23</p>	<p>APPROVED BY: KHLIM 2016/03/23</p>

1.0 SCOPE

The specification covers the performance requirements and test methods of Guardian, wire to board interconnect system.

2.0 PRODUCT DESCRIPTION

2.1 PRODUCT NAME AND SERIES NUMBER(S)

This specification covers the following board to board configurations:

Receptacle cable Assy mated to Vertical Plug (Backplane configuration) or Right Angle Plug (Backplane configuration)

- 151053 – Vertical Plug
- 151035 – Right Angle Plug
- 151034 – Receptacle Crimp Housing
- 151076 – TPA for Receptacle Housing
- 46819 – Crimp Terminal

2.2 DIMENSIONS, MATERIALS, PLATINGS AND MARKINGS

Refer to appropriate Sales drawings for detailed information regarding dimensions, materials, plating and markings.

2.3 SAFETY AGENCY APPROVALS

UL FILE NUMBER: E29179 VOL 10. SEC18
 CSA FILE NUMBER: 1779070 (LR 19980)

3.0 APPLICABLE DOCUMENTS AND SPECIFICATIONS

See sales drawings and the other sections of this specifications for the necessary referenced documents and specifications.

4.0 RATINGS

4.1 VOLTAGE

Power Module: 600 Volts (Refer to pad layout in Section 7.2)

Connector Rating per UL-1977

Connector voltage rating meets the connector approval level defined by UL 1977, Sect. 11 for spacing per table 11.1. Example: 1.2 mm for ≥ 250 volt; 3.2 mm for ≤ 250 volt.

Exception taken for spacing less than those specified are permitted, if the device complies with the requirements in the dielectric voltage withstanding test per Sect. 17.

Application Voltage Guideline

For application voltage requirements please refer to UL-60950 or other applicable standards, the creepage & clearance also needs to be determined based upon pads/traces on the PCB.

REVISION: A	ECR/ECN INFORMATION: EC No: S2016-0814 DATE: 2016 / 03 / 09	TITLE: GUARDIAN WIRE-TO-BOARD INTERCONNECT SYSTEMS	SHEET No. 2 of 12
DOCUMENT NUMBER: PS-151053-0000	CREATED / REVISED BY: CGOH/ 2016/03/09	CHECKED BY: EANG 2016/03/23	APPROVED BY: KHLIM 2016/03/23

4.2 CURRENT

6 AWG: 80 Amps

8 AWG: 60 Amps

** Tested in accordance with EIA-364-70.

Current rating is application dependent and should be used as a guideline.

Appropriate rating is required per ckt size, ambient conditions, copper trace size on the PCB, gross heating from adjacent modules/components and other factors that influence connector performance. Wire size and stranding, tin coated or bare copper, wire length & Crimp quality are other factors that influence current rating.

<u>REVISION:</u> A	<u>ECR/ECN INFORMATION:</u> EC No: S2016-0814 DATE: 2016 / 03 / 09	<u>TITLE:</u> GUARDIAN WIRE-TO-BOARD INTERCONNECT SYSTEMS	<u>SHEET No.</u> 3 of 12
<u>DOCUMENT NUMBER:</u> PS-151053-0000	<u>CREATED / REVISED BY:</u> CGOH/ 2016/03/09	<u>CHECKED BY:</u> EANG 2016/03/23	<u>APPROVED BY:</u> KHLIM 2016/03/23

4.3 TEMPERATURE

Operating temperature (including T-rise from applied current) is -40° C to +105° C.

Temperature life tested per EIA 364-17 Method A for 240 hrs@105° per table-8 to meet field temperature of 65° C for 10 years life. See Section 8.0 for detail test sequence of EIA-364-1000.01, Group I.

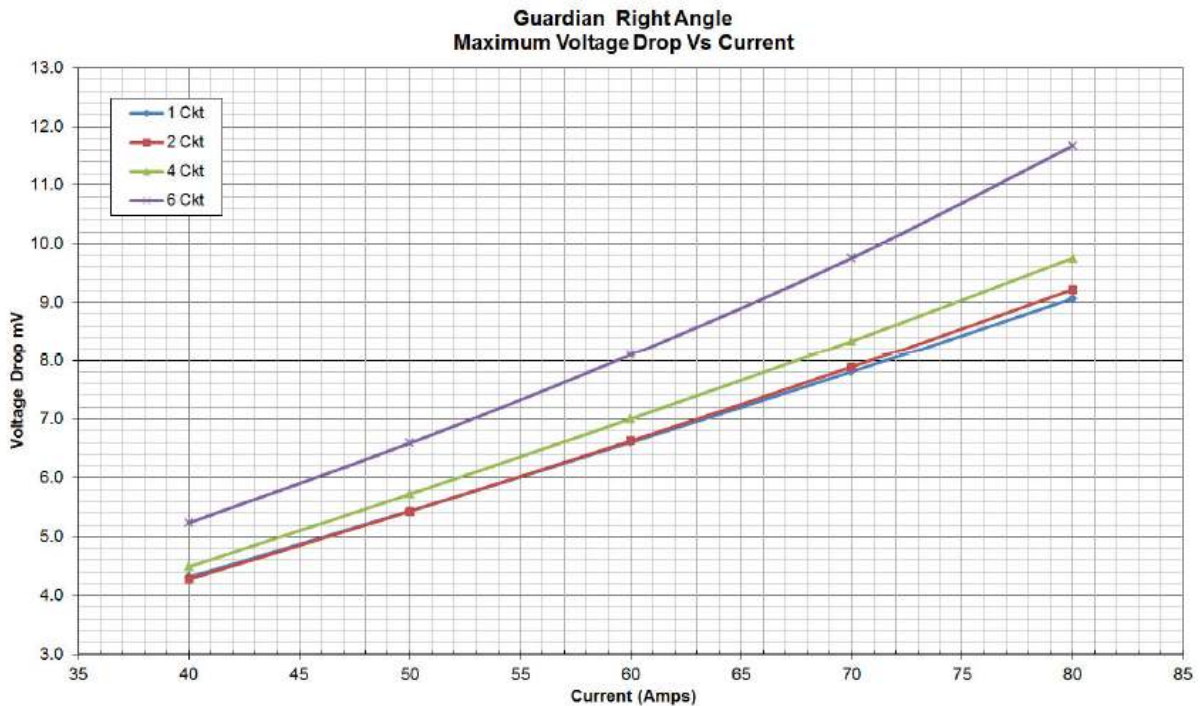
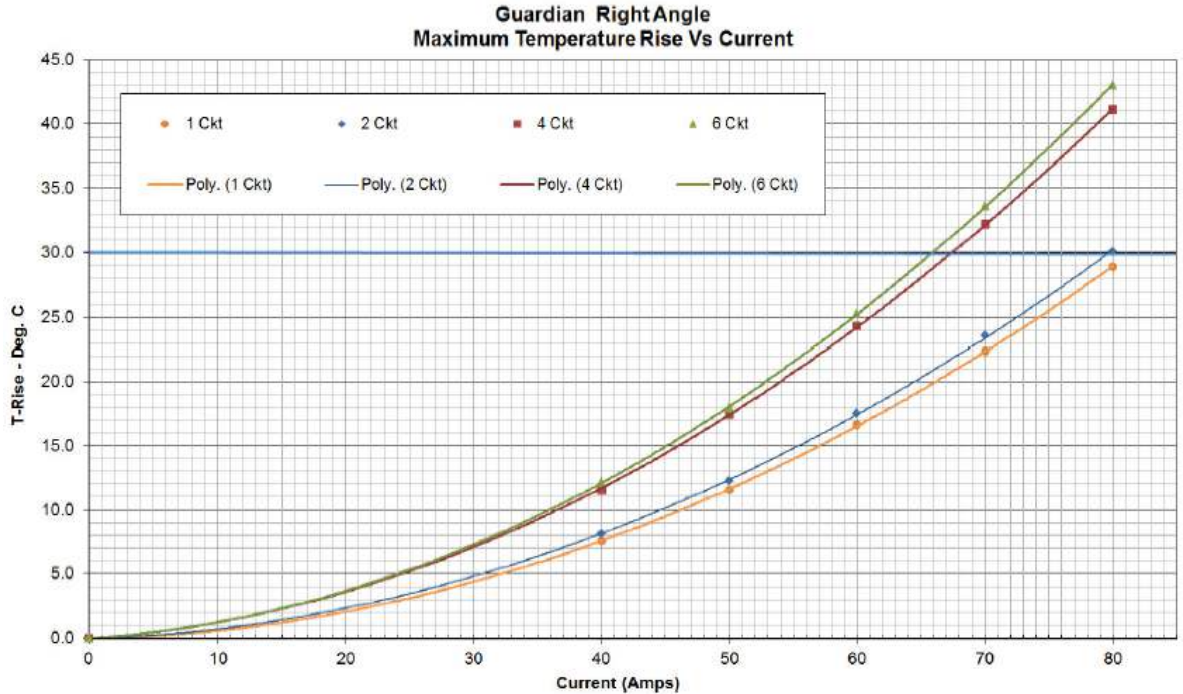

REVISION: A	ECR/ECN INFORMATION: EC No: S2016-0814 DATE: 2016 / 03 / 09	TITLE: GUARDIAN WIRE-TO-BOARD INTERCONNECT SYSTEMS	SHEET No. 4 of 12
DOCUMENT NUMBER: PS-151053-0000	CREATED / REVISED BY: CGOH/ 2016/03/09	CHECKED BY: EANG 2016/03/23	APPROVED BY: KHLIM 2016/03/23

5.0 PERFORMANCE

5.1 ELECTRICAL REQUIREMENTS

ITEM	DESCRIPTION	TEST CONDITION	REQUIREMENT
1	Contact Resistance (Low Level)	Mate connectors: apply a maximum voltage of 20 mV and a current of 100 mA . (Per EIA-364-23)	0.75 mΩ/ Blade Max
2	Voltage Drop @ Rated Current	Mate connectors: apply rated current. (Per EIA-364-70)	See Chart at Page 4
3	Insulation Resistance	Apply a voltage of 500 VDC between adjacent terminals and between terminals to ground. (Per EIA-364-21)	5,000 MΩ MINIMUM
4	Dielectric Withstanding Voltage	Apply a voltage 2200 VAC for 1 minute between adjacent terminals and between terminals to ground. (Per EIA-364-20)	No breakdown;
5	Temperature Rise	Mate connectors: measure the temperature rise at the rated current after: 96 hours (Per EIA-364-70)	See Chart at Page 4

5.2 MECHANICAL REQUIREMENTS

ITEM	DESCRIPTION	TEST CONDITION	REQUIREMENT
6	Mate force: Single Circuit	Mate connector (male to female) at a rate of 25.4 ± 6 mm per minute. Latch is push to open during this test. (Per EIA-364-37)	1.3kg Max
7	Unmate Force: Single Circuit	Unmate connector (male to female) at a rate of 25.4 ± 6 mm per minute. Latch is push to open during this test. (Per EIA-364-37)	0.3kg Min
8	Terminal Retention Force (in Housing for Plug)	Axial pullout force on the terminal in the housing at a rate of 25.4 ± 6 mm per minute.	750g Minimum per coupon

REVISION: A	ECR/ECN INFORMATION: EC No: S2016-0814 DATE: 2016 / 03 / 09	TITLE: GUARDIAN WIRE-TO-BOARD INTERCONNECT SYSTEMS	SHEET No. 5 of 12
DOCUMENT NUMBER: PS-151053-0000	CREATED / REVISED BY: CGOH/ 2016/03/09	CHECKED BY: EANG 2016/03/23	APPROVED BY: KHLIM 2016/03/23

5.2 MECHANICAL REQUIREMENTS (continued)

ITEM	DESCRIPTION	TEST CONDITION	REQUIREMENT
9	Durability	Mate connectors up to 5 cycles at a maximum rate of 10 cycles per minute per EIA-364-09	Maximum Change: 0.5mΩ
10	Vibration (Random)	Mate connectors and vibrate per EIA 364-28, test condition VII-D. 15 minutes per axis.	Maximum Change: 0.5 mΩ
11	Shock (Mechanical)	Mate connectors and shock at 50 g's with ½ sine wave (11 milliseconds) shocks in the ±X,±Y,±Z axes (18 shocks total).Per EIA-364-27	Maximum Change: 0.5 mΩ
12	Max Insertion Force in to PCB for Terminals with Compliant Pins	Insert contact at a rate of 25.4 ± 6 to Nominal PCB hole size.	8.5kg Max/ Pin
13	Min Extraction Force for Terminals with Compliant Pins	Pull out contacts at a rate of 25.4 ± 6 mm	1kg Min/ pin
14	Solder Resistance from rework	Per EIA-364-61, Test procedure 4 for compliant pin retention force	No Physical damage
15	Solder Resistance from rework	Per EIA-364-61, Test procedure 2 Test Condition II)	No Physical damage.
16	Crimp Wire Retention to Housing	Axial pullout force on the wire in the receptacle housing at a rate of 25.4 ± 6 mm per minute.	20kgf Min
17	Crimp Terminal to Wire Pull Force	Axial pullout force on the wire to the Crimp terminal at a rate of 25.4 ± 6 mm per minute.	6AWG: 9.7kgf Min

REVISION:	ECR/ECN INFORMATION:	TITLE:		SHEET No.
A	EC No: S2016-0814 DATE: 2016 / 03 / 09	GUARDIAN WIRE-TO-BOARD INTERCONNECT SYSTEMS		6 of 12
DOCUMENT NUMBER:	CREATED / REVISED BY:	CHECKED BY:	APPROVED BY:	
PS-151053-0000	CGOH/ 2016/03/09	EANG 2016/03/23	KHLIM 2016/03/23	

5.3 ENVIRONMENTAL REQUIREMENTS

TEM	DESCRIPTION	TEST CONDITION	REQUIREMENT										
18	Shock (Thermal)	Mate connectors; expose to 10 cycles of: <table border="0"> <tr> <td><u>Temperature °C</u></td> <td><u>Duration (Minutes)</u></td> </tr> <tr> <td>-55 +0/-5</td> <td>30</td> </tr> <tr> <td>Transfer</td> <td>5 MAXIMUM</td> </tr> <tr> <td>+85 +3/-0</td> <td>30</td> </tr> <tr> <td>Transfer</td> <td>5 MAXIMUM</td> </tr> </table> Per EIA-364-32F	<u>Temperature °C</u>	<u>Duration (Minutes)</u>	-55 +0/-5	30	Transfer	5 MAXIMUM	+85 +3/-0	30	Transfer	5 MAXIMUM	Maximum Change: 0.5 mΩ
<u>Temperature °C</u>	<u>Duration (Minutes)</u>												
-55 +0/-5	30												
Transfer	5 MAXIMUM												
+85 +3/-0	30												
Transfer	5 MAXIMUM												
19	Thermal Aging	Mate connectors; expose to: 240 hours at 105 ± 2°C Per EIA-364-17	Maximum Change: 0.5 mΩ										
20	Thermal Aging (Pre-conditioning)	Mate connectors; expose to: 120 hours at 105 ± 2°C Per EIA-364-17	Maximum Change: 0.5 mΩ										
21	Humidity (Cyclic)	Mate connectors: cycle per EIA-364-31: 24 cycles at temperature 25 ± 3°C at 80 ± 5% relative humidity and 65 ± 3°C at 50 ± 5% relative humidity; dwell time of 1.0 hour; ramp time of 0.5 hours. {Note: Remove surface moisture and air dry for 1 hour prior to measurements.}	Maximum Change: 0.5 mΩ										
22	Dust Test	Un-mated 1 hour duration 25 ± 3°C at 50 ± 5% relative humidity dust mass of 9g/ft ³ at rate of 300 m/min. Per EIA-364-91	Maximum Change: 0.5 mΩ										
23	Mixed Flowing Gas (MFG)	168 hours un-mated, 168 hours mated, Test per EIA-364-65, method 2A	Maximum Change: 0.5 mΩ										
24	Solderability	Steam Aging: 8 hr ± 15 mins Solder: 5 ± 0.5s Temp: 260 ± 5 °C Non activated flux.	Solder coverage: 95% MINIMUM (per SMES-152)										
25	Thermal Disturbance	Cycle Connector between 15 ± 3°C and 85 ± 3°C. Ramp should be a minimum of 2°C/ minute and dwell should be insure that the contacts reach the temperature extreme (a minimum of 5 minutes). Humidity is not controlled. Perform 10 cycles.	Maximum Change: 0.5 mΩ										

REVISION:	ECR/ECN INFORMATION:	TITLE:	SHEET No.
A	EC No: S2016-0814 DATE: 2016 / 03 / 09	GUARDIAN WIRE-TO-BOARD INTERCONNECT SYSTEMS	7 of 12
DOCUMENT NUMBER:	CREATED / REVISED BY:	CHECKED BY:	APPROVED BY:
PS-151053-0000	CGOH/ 2016/03/09	EANG 2016/03/23	KHLIM 2016/03/23

5.3 ENVIRONMENTAL REQUIREMENTS (Con't)

TEM	DESCRIPTION	TEST CONDITION	REQUIREMENT
26	Thermal Cycling	Cycle Connector between $15 \pm 3^{\circ}\text{C}$ and $85 \pm 3^{\circ}\text{C}$. Ramp should be a minimum of $2^{\circ}\text{C}/\text{minute}$ and dwell should be insure that the contacts reach the temperature extreme (a minimum of 5 minutes). Humidity is not controlled. Perform 500 cycles.	Maximum Change: 0.5 mΩ

6.0 PACKAGING

Parts shall be packaged per Packaging specification (refer to Sales drawing) to protect against damage during handling, transit and storage.

REVISION: A	ECR/ECN INFORMATION: EC No: S2016-0814 DATE: 2016 / 03 / 09	TITLE: GUARDIAN WIRE-TO-BOARD INTERCONNECT SYSTEMS	SHEET No. 8 of 12
DOCUMENT NUMBER: PS-151053-0000	CREATED / REVISED BY: CGOH/ 2016/03/09	CHECKED BY: EANG 2016/03/23	APPROVED BY: KHLIM 2016/03/23

7.0 PRINTED CIRCUIT BOARD SPECIFICATION

7.1 PCB THROUGH HOLE SPEC.

Profile for 1.02mm (finish) holes:

TIN PLATED OR OSP HOLE DIMENSIONS IN MM/IN

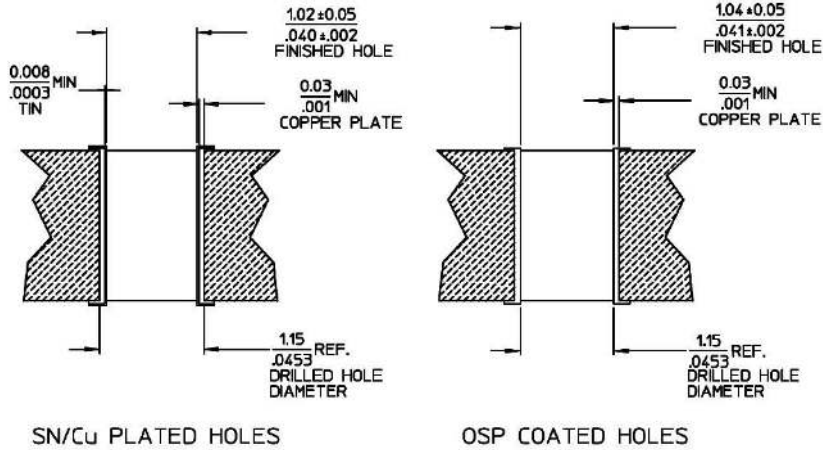

Notes:

1. The finished hole size is the critical feature for proper performance of the compliant pin terminal. The reference drill sizes listed are recommended by Molex to achieve the finished PCB hole size.
2. Depending on the specific manufacturer's plating process, a different drill size can be used to achieve the required finished PCB hole size.

7.2 TYPICAL PCB PADS LAYOUT

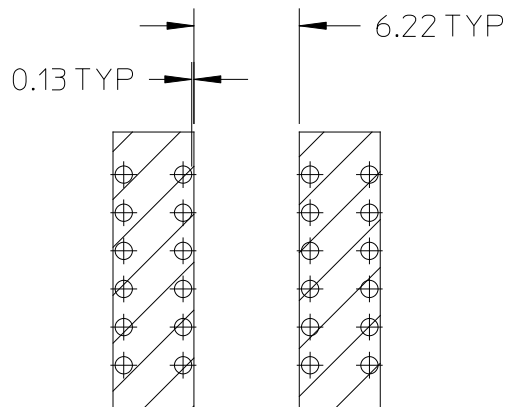

REVISION: A	ECR/ECN INFORMATION: EC No: S2016-0814 DATE: 2016 / 03 / 09	TITLE: GUARDIAN WIRE-TO-BOARD INTERCONNECT SYSTEMS	SHEET No. 9 of 12
DOCUMENT NUMBER: PS-151053-0000	CREATED / REVISED BY: CGOH/ 2016/03/09	CHECKED BY: EANG 2016/03/23	APPROVED BY: KHLIM 2016/03/23

7.3 SOLDERING PROFILE

(This profile is per JEDEC J-STD-020D.1) and it is for guide line only. Please see notes for additional information).

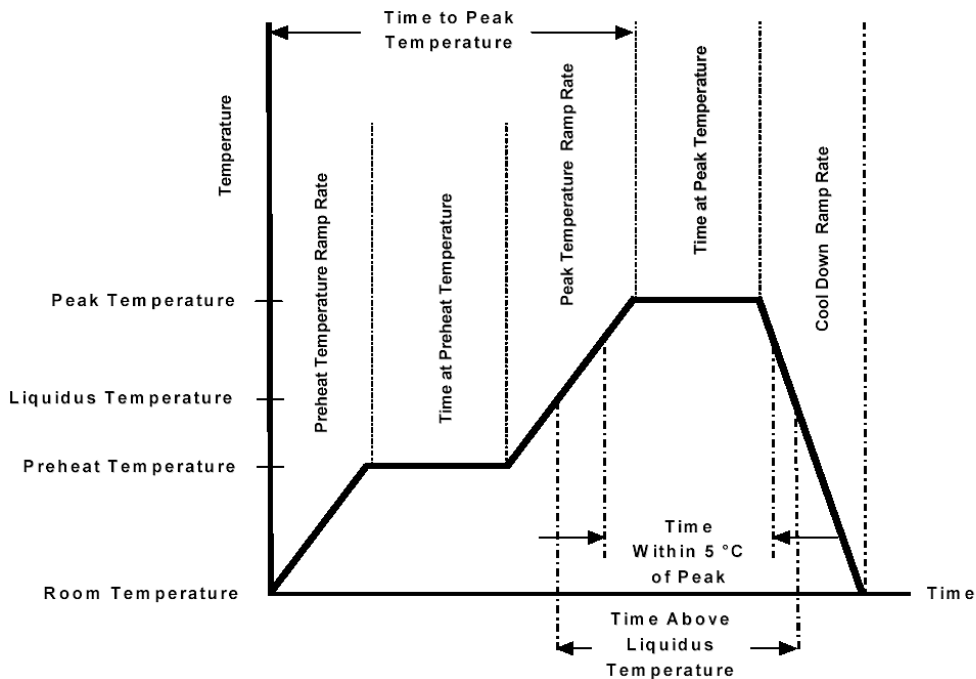

Description	Requirement
Average Ramp Rate	3°C/sec Max
Preheat Temperature	150°C Min to 200°C Max
Preheat Time	60 to 180 sec
Ramp to Peak	3°C/sec Max
Time over Liquids (217°C)	60 to 150 sec
Peak Temperature	260 +0/-5°C
Time within 5°C of Peak	20 to 40 sec
Ramp - Cool Down	6°C/sec Max
Time 25°C to Peak	8 min Max

Notes:

1. Temperature indicated refers to the PCB surface temperature at solder tail area.
2. Connector can withstand up to 3 reflow cycles with a cool-down to room temperature in-between.
3. Actual reflow profile also depends on equipment, solder paste, PCB thickness, and other components on the board. Please consult your solder paste & reflow equipment manufacturer for their recommendations to adopt a suitable process.

REVISION: A	ECR/ECN INFORMATION: EC No: S2016-0814 DATE: 2016 / 03 / 09	TITLE: GUARDIAN WIRE-TO-BOARD INTERCONNECT SYSTEMS	SHEET No. 10 of 12
DOCUMENT NUMBER: PS-151053-0000	CREATED / REVISED BY: CGOH/ 2016/03/09	CHECKED BY: EANG 2016/03/23	APPROVED BY: KHLIM 2016/03/23

8.0 TEST SEQUENCE

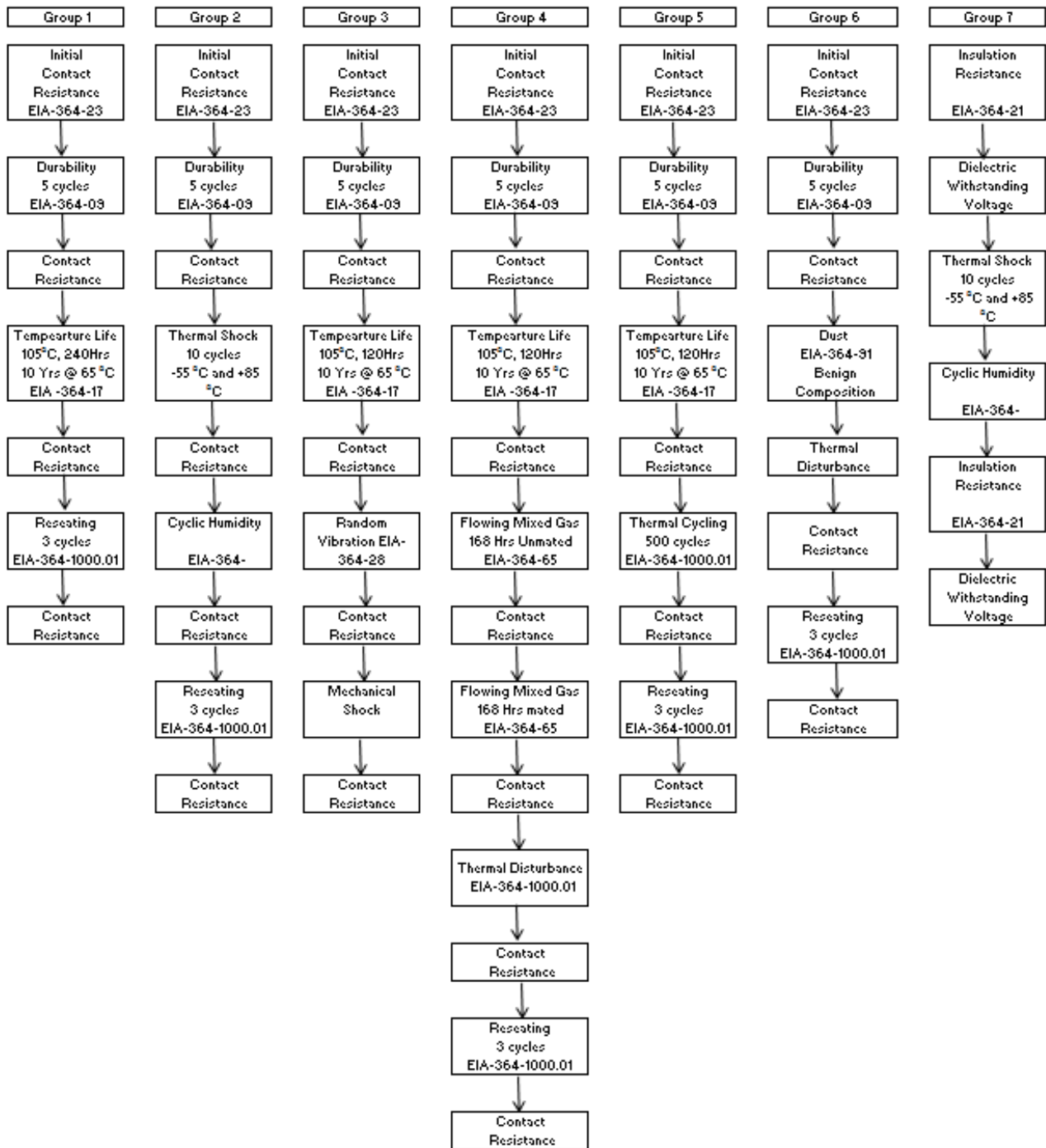

REVISION: A	ECR/ECN INFORMATION: EC No: S2016-0814 DATE: 2016 / 03 / 09	TITLE: GUARDIAN WIRE-TO-BOARD INTERCONNECT SYSTEMS	SHEET No. 11 of 12
DOCUMENT NUMBER: PS-151053-0000	CREATED / REVISED BY: CGOH/ 2016/03/09	CHECKED BY: EANG 2016/03/23	APPROVED BY: KHLIM 2016/03/23

8.0 TEST SEQUENCE (CON'T)

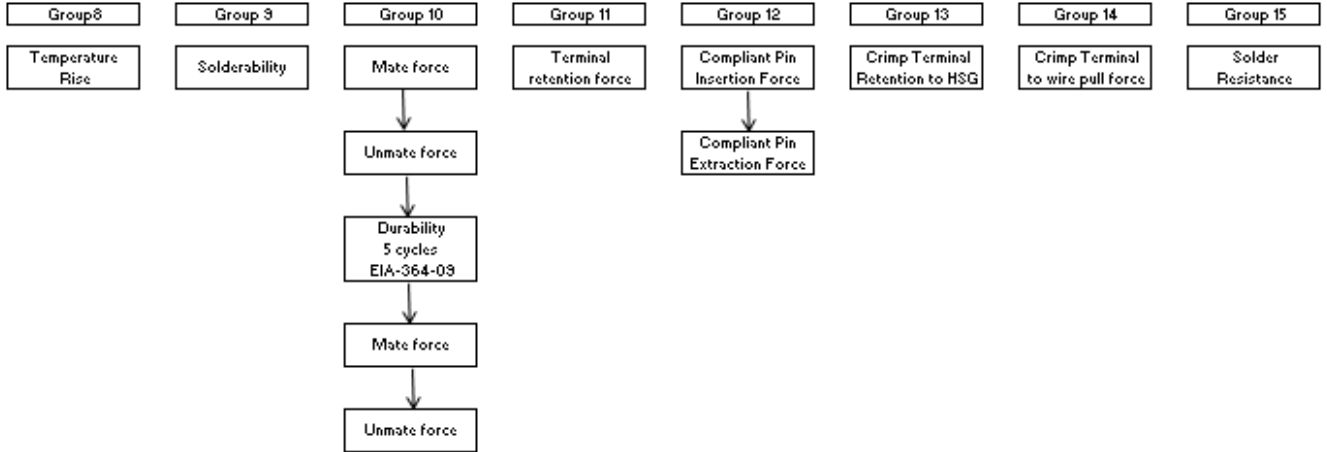

REVISION: A	ECR/ECN INFORMATION: EC No: S2016-0814 DATE: 2016 / 03 / 09	TITLE: GUARDIAN WIRE-TO-BOARD INTERCONNECT SYSTEMS	SHEET No. 12 of 12
DOCUMENT NUMBER: PS-151053-0000	CREATED / REVISED BY: CGOH/ 2016/03/09	CHECKED BY: EANG 2016/03/23	APPROVED BY: KHLIM 2016/03/23