

DATA SHEET

2322 615 1....
Surface mount NTC thermistors

Product specification
Supersedes data of 17th May 1999
File under BCcomponents, BC02

2001 Mar 27

Surface mount NTC thermistors

2322 615 1....

FEATURES

- High sensitivity
- High accuracy over a wide temperature range
- Taped on reel
- Suitable for wave or reflow soldering.

APPLICATION

- Temperature compensation, sensing and protection in, for example:
 - Battery chargers
 - Consumer equipment
 - Office equipment.

DESCRIPTION

Size 0805 chip thermistors with a negative temperature coefficient and silver palladium contacts⁽¹⁾. The device has no marking.

(1) NiSn contacts are available on request.

PACKAGING

Packaged in punched type paper tape on reel of 4000 units.

QUICK REFERENCE DATA

PARAMETER	VALUE
Resistance value at 25 °C	100 Ω to 470 kΩ
Tolerance on R ₂₅ -value	±5%; ±10%
Tolerance on B _{25/85} -value	see Table 2
Maximum dissipation at 25 °C	210 mW
Operating temperature range	-55 to +150 °C
Climatic category	40/125/56
Mass	≈0.015 g

MECHANICAL DATA

Outline

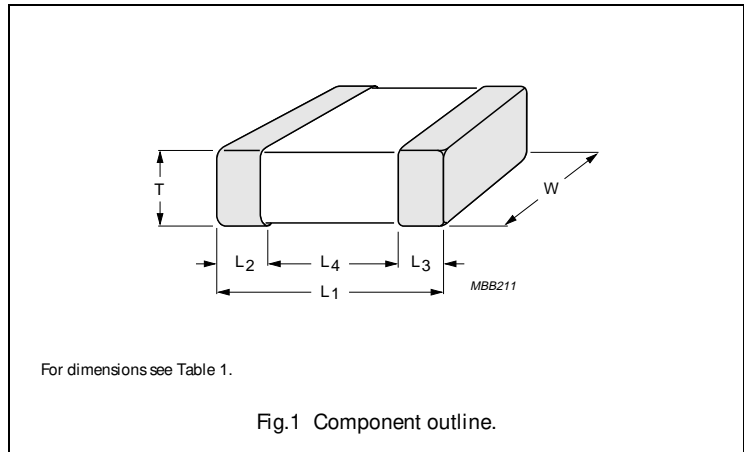

Table 1 Component dimensions; see Fig.1

L ₁ (mm)	W (mm)	T		L ₂ and L ₃ (mm)	L ₄ MIN. (mm)
		MIN. (mm)	MAX. (mm)		
2.0 ±0.2	1.25 ±0.2	0.5	1.25	0.5 ±0.25	0.5

Surface mount NTC thermistors

2322 615 1....

ELECTRICAL CHARACTERISTICS

Unless otherwise stated, measurements are in accordance with "IEC publication 60539"; see also Table 2

PARAMETER	VALUE
Tolerance on R_{25}	$\pm 5\%$; $\pm 10\%$
Tolerance on $B_{25/85}$ -value	see Table 2
Climatic category	40/125/56
Maximum dissipation at 25 °C	210 mW
Thermal time constant τ	≈ 10 s
Operating temperature range	-55 to +150 °C
R/T values	see Tables 13 to 24

Table 2 R_{25} -values, $B_{25/85}$ -values and catalogue numbers; see Tables 4 to 24

R_{25} (Ω)	$B_{25/85}$ -VALUE (K)	TOLERANCE ON $B_{25/85}$ (%)	CATALOGUE NUMBER 2322 615 1....	
			$\pm 5\%$ TOL. ON R_{25}	$\pm 10\%$ TOL. ON R_{25}
100	2880	± 3	3101	2101
220	2990	± 3	3221	2221
330	3041	± 3	3331	2331
470	3136	± 3	3471	2471
680	3270	± 3	3681	2681
1000	3390	± 3	3102	2102
2200	3680	± 3	3222	2222
3300	3830	± 3	3332	2332
4700	3560	± 1	3472	2472
5000	3560	± 1	3502	2502
10000	3620	± 1	3103	2103
15000	3528	± 1	3153	2153
22000	3930	± 1.5	3223	2223
33000	3960	± 3	3333	2333
47000	4090	± 1.5	3473	2473
68000	3740	± 3	3683	2683
100000	3650	± 1	3104	2104
150000	3807	± 3	3154	2154
330000	4015	± 3	3334	2334
470000	4130	± 3	3474	2474

Table 3 Solderability and resistance to soldering heat

IEC 60068-2-20	TEST METHOD	TEST	PROCEDURE	REQUIREMENTS
6	Tc	solderability	3 s at 215 °C; 2 s at 235 °C	$\Delta R/R < 5\%$
		resistance to soldering heat	10 s at 260 °C	$\Delta R/R < 5\%$

Surface mount NTC thermistors

2322 615 1...

Table 4 Resistance values at intermediate temperatures with R_{25} at 100 Ω ; see also Table 2

T_{oper} (°C)	CATALOGUE NUMBER 2322 615 1.101						
	R_T/R_{25}	TC (%/K)	R_T (Ω)	5% TOL. $\Delta R/R$ (%)	5% TOL. ΔT (K)	10% TOL. $\Delta R/R$ (%)	10% TOL. ΔT (K)
-40	13.64	-4.97	1363.6	13.56	2.73	18.97	3.82
-35	10.68	-4.80	1068.1	12.73	2.65	18.10	3.77
-30	8.435	-4.64	843.5	11.94	2.57	17.27	3.72
-25	6.715	-4.48	671.5	11.17	2.49	16.47	3.67
-20	5.387	-4.33	538.7	10.44	2.41	15.70	3.62
-15	4.353	-4.19	535.3	9.74	2.32	14.96	3.57
-10	3.543	-4.05	354.3	9.06	2.24	14.25	3.52
-5	2.904	-3.92	290.4	8.41	2.15	13.57	3.47
0	2.395	-3.79	239.5	7.79	2.06	12.92	3.41
5	1.988	-3.66	198.8	7.19	1.96	12.29	3.35
10	1.660	-3.55	166.0	6.61	1.86	11.69	3.30
15	1.394	-3.43	139.4	6.05	1.76	11.10	3.23
20	1.178	-3.32	117.8	5.52	1.66	10.54	3.17
25	1.000	-3.22	100.0	5.00	1.55	10.00	3.11
30	0.8531	-3.12	85.34	5.50	1.76	10.52	3.37
35	0.7319	-3.02	73.19	5.99	1.98	11.03	3.65
40	0.6307	-2.93	63.07	6.46	2.20	11.53	3.93
45	0.5459	-2.84	54.59	6.92	2.43	12.02	4.23
50	0.4746	-2.76	47.46	7.37	2.67	12.49	4.53
55	0.4143	-2.68	41.43	7.81	2.92	12.95	4.84
60	0.3631	-2.60	36.31	8.24	3.17	13.39	5.15
65	0.3194	-2.52	31.94	8.66	3.43	13.83	5.48
70	0.2820	-2.45	28.20	9.06	3.70	14.26	5.81
75	0.2499	-2.38	24.99	9.46	3.97	14.67	6.16
80	0.2222	-2.32	22.22	9.85	4.25	15.08	6.51
85	0.1982	-2.25	19.82	10.22	4.54	15.47	6.87
90	0.1774	-2.19	17.74	10.59	4.83	15.86	7.24
95	0.1592	-2.13	15.92	10.95	5.14	16.23	7.62
100	0.1433	-2.07	14.33	11.30	5.45	16.60	8.00
105	0.1294	-2.02	12.94	11.64	5.77	16.96	8.40
110	0.1171	-1.97	11.71	11.98	6.09	17.31	8.80
115	0.1063	-1.92	10.63	12.30	6.42	17.65	9.22
120	0.0967	-1.87	9.67	12.62	6.76	17.99	9.64
125	0.0882	-1.82	8.82	12.93	7.11	18.31	10.07
130	0.0806	-1.77	8.06	13.24	7.47	18.63	10.51
135	0.0739	-1.73	7.39	13.54	7.83	18.94	10.96
140	0.0678	-1.69	6.78	13.83	8.20	19.25	11.41
145	0.0624	-1.65	6.24	14.11	8.58	19.55	11.88
150	0.0575	-1.61	5.75	14.39	8.96	19.84	12.36

Surface mount NTC thermistors

2322 615 1...

Table 5 Resistance values at intermediate temperatures with R_{25} at 220 Ω ; see also Table 2

T_{oper} (°C)	CATALOGUE NUMBER 2322 615 1.221						
	R_T/R_{25}	TC (%/K)	R_T (Ω)	5% TOL. $\Delta R/R$ (%)	5% TOL. ΔT (K)	10% TOL. $\Delta R/R$ (%)	10% TOL. ΔT (K)
-40	13.68	-4.86	3008.5	18.98	3.91	13.57	2.79
-35	10.76	-4.72	2367.9	18.13	3.84	12.76	2.70
-30	8.532	-4.58	1877.0	17.31	3.78	11.97	2.62
-25	6.810	-4.44	1498.1	16.52	3.72	11.22	2.53
-20	5.472	-4.31	1203.8	15.75	3.66	10.49	2.43
-15	4.425	-4.18	973.6	15.02	3.59	9.79	2.34
-10	3.602	-4.06	792.4	14.31	3.53	9.12	2.25
-5	2.949	-3.94	648.9	13.63	3.46	8.46	2.15
0	2.430	-3.82	534.5	12.97	3.39	7.83	2.05
5	2.013	-3.71	442.8	12.33	3.33	7.23	1.95
10	1.677	-3.60	368.9	11.72	3.26	6.64	1.84
15	1.404	-3.50	308.9	11.13	3.18	6.07	1.74
20	1.182	-3.39	260.1	10.55	3.11	5.53	1.63
25	1.000	-3.30	220.0	10.00	3.03	5.00	1.52
30	0.8500	-3.20	187.0	10.54	3.29	5.51	1.72
35	0.7259	-3.11	159.7	11.06	3.55	6.01	1.93
40	0.6226	-3.03	137.0	11.67	3.83	6.50	2.15
45	0.5363	-2.94	118.0	12.08	4.10	6.98	2.37
50	0.4639	-2.86	102.1	12.56	4.39	7.45	2.60
55	0.4029	-2.78	88.63	13.04	4.69	7.90	2.84
60	0.3512	-2.71	77.26	13.51	4.99	8.35	3.08
65	0.3073	-2.64	67.60	13.96	5.30	8.78	3.33
70	0.2698	-2.57	59.36	14.41	5.62	9.21	3.59
75	0.2377	-2.50	52.30	14.84	5.94	9.62	3.85
80	0.2101	-2.43	46.23	15.27	6.27	10.03	4.12
85	0.1864	-2.37	41.00	15.69	6.62	10.43	4.40
90	0.1658	-2.31	36.47	16.09	6.96	10.82	4.68
95	0.1479	-2.25	32.54	16.49	7.32	11.20	4.97
100	0.1323	-2.20	29.12	16.88	7.69	11.57	5.27
105	0.1187	-2.14	26.12	17.26	8.06	11.93	5.57
110	0.1068	-2.09	23.50	17.63	8.44	12.29	5.88
115	0.0964	-2.04	21.20	18.00	8.83	12.63	6.20
120	0.0871	-1.99	19.17	18.36	9.23	12.98	6.52
125	0.0790	-1.94	17.37	18.71	9.63	13.31	6.85
130	0.0717	-1.90	15.78	19.05	10.04	13.64	7.19
135	0.0653	-1.85	14.37	19.38	10.46	13.96	7.54
140	0.0596	-1.81	13.11	19.71	10.89	14.27	7.89
145	0.0545	-1.77	11.99	20.03	11.33	14.58	8.24
150	0.0500	-1.73	10.99	20.35	11.78	14.88	8.61

Surface mount NTC thermistors

2322 615 1...

Table 6 Resistance values at intermediate temperatures with R_{25} at 330 Ω ; see also Table 2

T_{oper} (°C)	CATALOGUE NUMBER 2322 615 1.331						
	R_T/R_{25}	TC (%/K)	R_T (Ω)	5% TOL. $\Delta R/R$ (%)	5% TOL. ΔT (K)	10% TOL. $\Delta R/R$ (%)	10% TOL. ΔT (K)
-40	14.99	-5.16	4945.1	13.88	2.69	19.31	3.74
-35	11.63	-4.98	3838.4	13.02	2.62	18.40	3.70
-30	9.110	-4.80	3006.2	12.20	2.54	17.54	3.65
-25	7.196	-4.64	2374.5	11.40	2.46	16.71	3.60
-20	5.730	-4.48	1890.7	10.65	2.38	15.91	3.55
-15	4.597	-4.33	1517.1	9.92	2.29	15.15	3.50
-10	3.716	-4.19	1226.3	9.22	2.20	14.42	3.44
-5	3.024	-4.05	998.1	8.54	2.11	13.71	3.39
0	2.478	-3.92	817.7	7.90	2.01	13.04	3.32
5	2.043	-3.80	674.2	7.27	1.92	12.38	3.26
10	1.695	-3.68	559.2	6.67	1.81	11.75	3.19
15	1.414	-3.57	466.5	6.10	1.71	11.15	3.12
20	1.186	-3.46	391.3	5.54	1.60	10.56	3.05
25	1.000	-3.36	330.0	5.00	1.49	10.00	2.98
30	0.8475	-3.26	279.7	5.52	1.69	10.55	3.23
35	0.7217	-3.17	238.2	6.03	1.90	11.08	3.50
40	0.6174	-3.08	203.7	6.53	2.12	11.60	3.77
45	0.5305	-2.99	175.1	7.02	2.35	12.11	4.05
50	0.4578	-2.91	151.1	7.49	2.58	12.61	4.34
55	0.3966	-2.83	130.9	7.95	2.81	13.09	4.63
60	0.3450	-2.75	113.8	8.41	3.05	13.57	4.93
65	0.3012	-2.68	99.39	8.85	3.30	14.03	5.24
70	0.2639	-2.61	87.08	9.28	3.56	14.49	5.55
75	0.2320	-2.54	76.56	9.70	3.82	14.93	5.87
80	0.2046	-2.48	67.53	10.12	4.09	15.36	6.20
85	0.1811	-2.41	59.76	10.52	4.36	15.79	6.54
90	0.1608	-2.35	53.05	10.92	4.64	16.20	6.88
95	0.1431	-2.30	47.23	11.31	4.93	16.61	7.23
100	0.1278	-2.24	42.17	11.69	5.22	17.00	7.59
105	0.1144	-2.19	37.75	12.06	5.52	17.39	7.96
110	0.1027	-2.13	33.89	12.42	5.82	17.77	8.33
115	0.0924	-2.08	30.50	12.78	6.13	18.15	8.71
120	0.0834	-2.03	27.51	13.12	6.45	18.51	9.10
125	0.0754	-1.99	24.88	13.47	6.77	18.87	9.49
130	0.0683	-1.94	22.55	13.80	7.10	19.22	9.89
135	0.0621	-1.90	20.49	14.13	7.44	19.56	10.30
140	0.0565	-1.86	18.65	14.45	7.75	19.90	10.72
145	0.0516	-1.82	17.01	14.77	8.13	20.23	11.14
150	0.0471	-1.78	15.55	15.08	8.49	20.56	11.57

Surface mount NTC thermistors

2322 615 1...

Table 7 Resistance values at intermediate temperatures with R_{25} at 470 Ω ; see also Table 2

T_{oper} (°C)	CATALOGUE NUMBER 2322 615 1.471						
	R_T/R_{25}	TC (%/K)	R_T (Ω)	5% TOL. $\Delta R/R$ (%)	5% TOL. ΔT (K)	10% TOL. $\Delta R/R$ (%)	10% TOL. ΔT (K)
-40	17.04	-5.54	8009.6	14.32	2.58	19.77	3.57
-35	12.99	-5.31	6106.7	13.40	2.52	18.80	3.54
-30	10.02	-5.10	4708.2	12.52	2.46	17.87	3.51
-25	7.804	-4.90	3667.7	11.68	2.38	16.99	3.47
-20	6.138	-4.71	2885.0	10.87	2.31	16.15	3.43
-15	4.872	-4.53	2289.8	10.11	2.23	15.35	3.39
-10	3.900	-4.37	1832.8	9.38	2.14	14.58	3.34
-5	3.146	-4.22	1478.7	8.67	2.06	13.85	3.28
0	2.557	-4.07	1201.9	8.00	1.96	13.14	3.23
5	2.093	-3.94	983.7	7.35	1.87	12.46	3.17
10	1.725	-3.81	810.5	6.73	1.77	11.81	3.10
15	1.430	-3.69	672.0	6.13	1.66	11.19	3.03
20	1.192	-3.57	560.4	5.56	1.55	10.58	2.96
25	1.000	-3.47	470.0	5.00	1.44	10.00	2.89
30	0.8431	-3.36	396.3	5.54	1.65	10.56	3.14
35	0.7144	-3.26	335.8	6.06	1.86	11.12	3.41
40	0.6083	-3.17	285.9	6.58	2.07	11.65	3.68
45	0.523	-3.08	244.5	7.08	2.30	12.18	4.95
50	0.4470	-3.00	210.1	7.57	2.53	12.69	4.24
55	0.3856	-2.92	181.2	8.05	2.76	13.19	4.52
60	0.3339	-2.84	156.9	8.51	3.00	13.68	4.82
65	0.2903	-2.76	136.4	8.97	3.25	14.16	5.12
70	0.2533	-2.69	119.0	9.42	3.50	14.63	5.43
75	0.2218	-2.62	104.2	9.85	3.75	15.08	5.75
80	0.1948	-2.56	91.56	10.28	4.02	15.53	6.07
85	0.1717	-2.50	80.69	10.70	4.29	15.97	6.40
90	0.1518	-2.44	71.33	11.11	4.56	16.40	6.73
95	0.1346	-2.38	63.25	11.51	4.84	16.82	7.07
100	0.1196	-2.32	56.24	11.91	5.13	17.23	7.42
105	0.1067	-2.27	50.14	12.29	5.42	17.64	7.78
110	0.0954	-2.22	44.82	12.67	5.72	18.04	8.14
115	0.0855	-2.17	40.17	13.04	6.02	18.42	8.50
120	0.0768	-2.12	36.09	13.40	6.33	18.80	8.88
125	0.0691	-2.07	32.50	13.76	6.64	19.18	9.26
130	0.0624	-2.03	29.33	14.11	6.96	19.55	9.64
135	0.0565	-1.98	26.53	14.46	7.29	19.91	10.03
140	0.0512	-1.94	24.05	14.79	7.62	20.26	10.43
145	0.0465	-1.90	21.85	15.12	7.95	20.61	10.84
150	0.0423	-1.86	19.89	15.45	8.30	20.95	11.25

Surface mount NTC thermistors

2322 615 1...

Table 8 Resistance values at intermediate temperatures with R_{25} at 680 Ω ; see also Table 2

T_{oper} (°C)	CATALOGUE NUMBER 2322 615 1.681						
	R_T/R_{25}	TC (%/K)	R_T (Ω)	5% TOL. $\Delta R/R$ (%)	5% TOL. ΔT (K)	10% TOL. $\Delta R/R$ (%)	10% TOL. ΔT (K)
-40	19.23	-5.77	13073.7	14.74	2.56	20.20	3.50
-35	14.50	-5.53	9858.6	13.77	2.49	19.19	3.47
-30	11.06	-5.31	7519.7	12.85	2.42	18.22	3.43
-25	8.525	-5.10	5797.3	11.97	2.35	17.30	3.39
-20	6.638	-4.91	4514.1	11.14	2.27	16.43	3.35
-15	5.217	-4.73	3547.8	10.33	2.19	15.59	3.30
-10	4.137	-4.56	2812.8	9.57	2.10	14.79	3.24
-5	3.307	-4.40	2248.4	8.84	2.01	14.02	3.19
0	2.664	-4.25	1811.2	8.13	1.91	13.28	3.12
5	1.161	-4.11	1469.7	7.46	1.81	12.57	3.06
10	1.766	-3.98	1200.8	6.81	1.71	11.89	2.99
15	1.452	-3.85	987.5	6.18	1.61	11.24	2.92
20	1.202	-3.73	817.0	5.58	1.50	10.61	2.84
25	1.000	-3.62	680.0	5.00	1.38	10.00	2.77
30	0.8369	-3.51	569.1	5.56	1.59	10.59	3.02
35	0.7041	-3.41	478.8	6.11	1.79	11.16	3.28
40	0.5953	-3.31	404.8	6.65	2.01	11.72	3.55
45	0.5058	-3.21	343.9	7.17	2.23	12.27	3.82
50	0.4317	-3.12	293.5	7.68	2.46	12.81	4.10
55	0.3700	-3.04	251.6	8.18	2.69	13.33	4.39
60	0.3185	-2.96	216.6	8.67	2.93	13.84	4.68
65	0.2752	-2.88	187.2	9.14	3.17	14.34	4.98
70	0.2388	-2.81	162.4	9.61	3.42	14.83	5.29
75	0.2079	-2.73	141.4	10.07	3.68	15.31	5.60
80	0.1816	-2.67	123.5	10.51	3.94	15.78	5.92
85	0.1592	-2.60	108.3	10.95	4.21	16.23	6.24
90	0.1400	-2.54	95.23	11.38	4.49	16.68	6.58
95	0.1236	-2.48	84.02	11.80	4.77	17.12	6.92
100	0.1093	-2.42	74.34	12.21	5.05	17.55	7.26
105	0.0970	-2.36	65.98	12.61	5.34	17.97	7.61
110	0.0863	-2.31	58.71	13.01	5.64	18.39	7.97
115	0.0770	-2.25	52.38	13.39	5.94	18.79	8.34
120	0.0689	-2.20	46.86	13.77	6.25	19.19	8.71
125	0.0618	-2.15	42.02	14.15	6.57	19.58	9.09
130	0.0556	-2.11	37.78	14.51	6.89	19.96	9.47
135	0.0501	-2.06	34.04	14.87	7.21	20.34	9.86
140	0.0452	-2.02	30.74	15.22	7.54	20.71	10.26
145	0.0409	-1.98	27.82	15.57	7.88	21.07	10.67
150	0.0371	-1.93	25.23	15.91	8.22	21.43	11.08

Surface mount NTC thermistors

2322 615 1...

Table 9 Resistance values at intermediate temperatures with R_{25} at 1000 Ω ; see also Table 2

T_{oper} (°C)	CATALOGUE NUMBER 2322 615 1.102						
	R_T/R_{25}	TC (%/K)	R_T (Ω)	5% TOL. $\Delta R/R$ (%)	5% TOL. ΔT (K)	10% TOL. $\Delta R/R$ (%)	10% TOL. ΔT (K)
-40	21.42	-5.94	21424.1	15.11	2.54	20.57	3.47
-35	16.01	-5.70	16014.7	14.11	2.47	19.54	3.43
-30	12.11	-5.49	12107.4	13.16	2.40	18.55	3.38
-25	9.251	-5.28	9251.1	12.25	2.32	17.59	3.33
-20	7.140	-5.09	7139.5	11.38	2.24	16.68	3.28
-15	5.562	-4.90	5561.9	10.55	2.15	15.81	3.22
-10	4.372	-4.73	4371.5	9.75	2.06	14.98	3.17
-5	3.465	-4.57	3464.7	8.99	1.97	14.18	3.10
0	2.768	-4.42	2767.8	8.26	1.87	13.41	3.04
5	2.228	-4.27	2227.6	7.55	1.77	12.68	2.97
10	1.806	-4.13	1805.7	6.88	1.66	11.97	2.90
15	1.474	-4.00	1473.5	6.23	1.56	11.29	2.81
20	1.210	-3.88	1210.2	5.60	1.45	10.63	2.74
25	1.000	-3.76	1000.0	5.00	1.33	10.00	2.66
30	0.8311	-3.64	831.1	5.58	1.53	10.61	2.91
35	0.6946	-3.54	694.6	6.15	1.74	11.21	3.17
40	0.5835	-3.43	583.5	6.71	1.95	11.79	3.43
45	0.4927	-3.34	492.7	7.25	2.17	12.36	3.71
50	0.4180	-3.24	418.0	7.78	2.40	12.92	3.98
55	0.3563	-3.15	356.3	8.30	2.63	13.46	4.27
60	0.3050	-3.07	305.0	8.81	2.87	13.99	4.56
65	0.2622	-2.98	262.2	9.30	3.12	14.51	4.86
70	0.2263	-2.90	226.3	9.79	3.37	15.01	5.17
75	0.1961	-2.83	196.1	10.26	3.63	15.51	5.48
80	0.1705	-2.76	170.5	10.72	3.89	15.99	5.80
85	0.1489	-2.69	148.9	11.17	4.16	16.47	6.13
90	0.1304	-2.62	130.4	11.62	4.44	16.93	6.47
95	0.1146	-2.55	114.6	12.05	4.72	17.39	6.81
100	0.1010	-2.49	101.0	12.48	5.01	17.83	7.16
105	0.0893	-2.43	89.29	12.89	5.30	18.27	7.51
110	0.0792	-2.37	79.18	13.30	5.60	18.70	7.87
115	0.0704	-2.32	70.41	13.70	5.91	19.11	8.24
120	0.0628	-2.26	62.79	14.09	6.22	19.52	8.62
125	0.0561	-2.21	56.14	14.47	6.54	19.93	9.00
130	0.0503	-2.16	50.32	14.85	6.87	20.32	9.39
135	0.0452	-2.11	45.22	15.22	7.20	20.71	9.79
140	0.0407	-2.07	40.73	15.58	7.53	21.09	10.20
145	0.0368	-2.02	36.77	15.94	7.88	21.46	10.61
150	0.0333	-1.98	33.27	16.29	8.23	21.82	11.02

Surface mount NTC thermistors

2322 615 1...

Table 10 Resistance values at intermediate temperatures with R_{25} at 2000 Ω ; see also Table 2

T_{oper} (°C)	CATALOGUE NUMBER 2322 615 1.202						
	R_T/R_{25}	TC (%/K)	R_T (Ω)	5% TOL. $\Delta R/R$ (%)	5% TOL. ΔT (K)	10% TOL. $\Delta R/R$ (%)	10% TOL. ΔT (K)
-40	27.23	-6.21	54462.6	15.94	2.57	21.46	3.46
-35	20.06	-6.02	40118.4	14.88	2.47	20.35	3.38
-30	14.92	-5.83	29834.5	13.87	2.38	19.29	3.31
-25	11.20	-5.65	22393.8	12.89	2.28	18.27	3.24
-20	8.481	-5.47	16961.6	11.95	2.19	17.29	3.16
-15	6.480	-5.29	12960.5	11.05	2.09	16.34	3.09
-10	4.994	-5.13	9987.9	10.19	1.99	15.44	3.01
-5	3.880	-4.97	7760.8	9.36	1.89	14.57	2.93
0	3.393	-4.81	6078.6	8.56	1.78	13.73	2.86
5	2.399	-4.66	4797.7	7.79	1.67	12.93	2.78
10	1.908	-4.51	3815.0	7.05	1.56	12.15	2.69
15	1.528	-4.37	3055.3	6.34	1.45	11.41	2.61
20	1.232	-4.24	2463.8	5.66	1.34	10.69	2.52
25	1.000	-4.11	2000.0	5.00	1.22	10.00	2.44
30	0.8170	-3.98	1633.9	5.64	1.42	10.67	2.68
35	0.6715	-3.86	1343.1	6.26	1.62	11.32	2.93
40	0.5553	-3.74	1110.5	6.87	1.83	11.96	3.19
45	0.4618	-3.63	923.5	7.46	2.05	12.58	3.46
50	0.3861	-3.53	772.2	8.04	2.28	13.19	3.74
55	0.3245	-3.42	649.0	8.61	2.51	13.78	4.03
60	0.2742	-3.32	548.3	9.16	2.76	14.35	4.32
65	0.2327	-3.23	465.5	9.69	3.00	14.92	4.62
70	0.1985	-3.14	397.0	10.22	3.26	15.47	4.93
75	0.1701	-3.05	340.2	10.73	3.52	16.00	5.25
80	0.1464	-2.96	292.7	11.23	3.79	16.53	5.58
85	0.1265	-2.88	252.9	11.72	4.07	17.04	5.92
90	0.1097	-2.80	219.4	12.20	4.35	17.54	6.26
95	0.0956	-2.73	191.1	12.66	4.65	18.03	6.61
100	0.0835	-2.65	167.1	13.12	4.95	18.50	6.98
105	0.0733	-2.58	146.6	13.56	5.25	18.97	7.35
110	0.0645	-2.51	129.1	14.00	5.57	19.43	7.73
115	0.0570	-2.45	114.0	14.42	5.89	19.87	8.12
120	0.0505	-2.38	101.0	14.84	6.22	20.31	8.52
125	0.0449	-2.32	89.8	15.24	6.56	20.73	8.92
130	0.0400	-2.26	80.1	15.64	6.91	21.15	9.34
135	0.0358	-2.21	71.6	16.03	7.26	21.55	9.76
140	0.0321	-2.15	64.2	16.41	7.62	21.95	10.20
145	0.0289	-2.10	57.7	16.78	7.99	22.34	10.64
150	0.0260	-2.05	52.1	17.15	8.37	22.72	11.09

Surface mount NTC thermistors

2322 615 1...

Table 11 Resistance values at intermediate temperatures with R_{25} at 2200 Ω ; see also Table 2

T_{oper} (°C)	CATALOGUE NUMBER 2322 615 1.222						
	R_T/R_{25}	TC (%/K)	R_T (Ω)	5% TOL $\Delta R/R$ (%)	5% TOL ΔT (K)	10% TOL $\Delta R/R$ (%)	10% TOL ΔT (K)
-40	27.23	-6.21	59909	15.94	2.57	21.46	3.46
-35	20.06	-6.02	44130	14.88	2.47	20.35	3.38
-30	14.92	-5.83	12818	13.87	2.38	19.29	3.31
-25	11.20	-5.65	24633	12.89	2.28	18.27	3.24
-20	8.481	-5.47	18658	11.95	2.19	17.29	3.16
-15	6.480	-5.29	14257	11.05	2.09	16.34	3.09
-10	4.994	-5.13	10987	10.19	1.99	15.44	3.01
-5	3.880	-4.97	8537	9.36	1.89	14.57	2.93
0	3.393	-4.81	6686	8.56	1.78	13.73	2.86
5	2.399	-4.66	5278	7.79	1.67	12.93	2.78
10	1.908	-4.51	4196	7.05	1.56	12.15	2.69
15	1.528	-4.37	3361	6.34	1.45	11.41	2.61
20	1.232	-4.24	2710	5.66	1.34	10.69	2.52
25	1.000	-4.11	2200	5.00	1.22	10.00	2.44
30	0.8170	-3.98	1797	5.64	1.42	10.67	2.68
35	0.6715	-3.86	1477	6.26	1.62	11.32	2.93
40	0.5553	-3.74	1222	6.87	1.83	11.96	3.19
45	0.4618	-3.63	1016	7.46	2.05	12.58	3.46
50	0.3861	-3.53	849.4	8.04	2.28	13.19	3.74
55	0.3245	-3.42	714.0	8.61	2.51	13.78	4.03
60	0.2742	-3.32	603.2	9.16	2.76	14.35	4.32
65	0.2327	-3.23	512.0	9.69	3.00	14.92	4.62
70	0.1985	-3.14	436.7	10.22	3.26	15.47	4.93
75	0.1701	-3.05	374.2	10.73	3.52	16.00	5.25
80	0.1464	-2.96	322.0	11.23	3.79	16.53	5.58
85	0.1265	-2.88	278.2	11.72	4.07	17.04	5.92
90	0.1097	-2.80	241.4	12.20	4.35	17.54	6.26
95	0.0956	-2.73	210.2	12.66	4.65	18.03	6.61
100	0.0835	-2.65	183.8	13.12	4.95	18.50	6.98
105	0.0733	-2.58	161.3	13.56	5.25	18.97	7.35
110	0.0645	-2.51	142.0	14.00	5.57	19.43	7.73
115	0.0570	-2.45	125.4	14.42	5.89	19.87	8.12
120	0.0505	-2.38	111.2	14.84	6.22	20.31	8.52
125	0.0449	-2.32	98.81	15.24	6.56	20.73	8.92
130	0.0400	-2.26	88.10	15.64	6.91	21.15	9.34
135	0.0358	-2.21	78.78	16.03	7.26	21.55	9.76
140	0.0321	-2.15	70.65	16.41	7.62	21.95	10.20
145	0.0289	-2.10	63.52	16.78	7.99	22.34	10.64
150	0.0260	-2.05	57.26	17.15	8.37	22.72	11.09

Surface mount NTC thermistors

2322 615 1...

Table 12 Resistance values at intermediate temperatures with R_{25} at 3300 Ω ; see also Table 2

T_{oper} (°C)	CATALOGUE NUMBER 2322 615 1.332						
	R_T/R_{25}	TC (%/K)	R_T (Ω)	5% TOL. $\Delta R/R$ (%)	5% TOL. ΔT (K)	10% TOL. $\Delta R/R$ (%)	10% TOL. ΔT (K)
-40	32.8313	-6.58	108343.1	15.84	2.41	21.36	3.25
-35	23.7526	-6.37	78383.5	14.80	2.32	20.26	3.18
-30	17.3614	-6.17	57292.8	13.79	2.24	19.21	3.11
-25	12.8173	-5.97	42297.2	12.83	2.15	18.21	3.05
-20	9.5548	-5.78	31530.9	11.91	2.06	17.24	2.98
-15	7.1900	-5.59	23727.1	11.02	1.97	16.31	2.92
-10	5.4600	-5.42	18018.0	10.17	1.88	15.42	2.85
-5	4.1828	-5.24	13803.4	9.35	1.78	14.56	2.78
0	3.2317	-5.08	10664.7	8.56	1.69	13.73	2.70
5	2.5174	-4.92	8307.44	7.80	1.59	12.93	2.63
10	1.9765	-4.76	6522.40	7.06	1.48	12.16	2.55
15	1.5636	-4.61	5159.94	6.35	1.38	11.41	2.47
20	1.2461	-4.47	4112.00	5.66	1.27	10.69	2.39
25	1.0000	-4.33	3300.0	5.00	1.15	10.00	2.31
30	0.8080	-4.20	2666.31	5.64	1.34	10.67	2.54
35	0.6571	-4.07	2168.35	6.26	1.54	11.32	2.78
40	0.5377	-3.95	1774.45	6.86	1.74	11.95	3.03
45	0.4427	-3.83	1460.86	7.44	1.94	12.56	3.28
50	0.3666	-3.72	1209.65	8.01	2.15	13.15	3.54
55	0.3052	-3.61	1007.23	8.55	2.37	13.72	3.80
60	0.2555	-3.50	843.17	9.08	2.59	14.28	4.08
65	0.2150	-3.40	709.47	9.60	2.82	14.82	4.35
70	0.1818	-3.31	599.93	10.10	3.05	15.34	4.64
75	0.1545	-3.21	509.73	10.58	3.29	15.85	4.93
80	0.1318	-3.12	435.07	11.06	3.54	16.34	5.23
85	0.1130	-3.04	372.99	11.51	3.79	16.82	5.54
90	0.0973	-2.95	321.12	11.96	4.05	17.29	5.86
95	0.0841	-2.87	277.60	12.39	4.31	17.74	6.18
100	0.0730	-2.80	240.92	12.81	4.58	18.19	6.51
105	0.0636	-2.72	209.89	13.23	4.86	18.62	6.84
110	0.0556	-2.65	183.52	13.63	5.14	19.04	7.18
115	0.0488	-2.58	161.03	14.02	5.43	19.44	7.54
120	0.0430	-2.51	141.77	14.39	5.73	19.84	7.89
125	0.0379	-2.45	125.23	14.77	6.03	20.23	8.26
130	0.0336	-2.39	110.97	15.13	6.34	20.61	8.63
135	0.0299	-2.33	98.63	15.48	6.65	20.98	9.01
140	0.0266	-2.27	87.92	15.82	6.97	21.34	9.40
145	0.0238	-2.21	78.60	16.16	7.30	21.69	9.80
150	0.0214	-2.16	70.46	16.49	7.63	22.03	10.20

Surface mount NTC thermistors

2322 615 1...

Table 13 Resistance values at intermediate temperatures with R_{25} at 4700 Ω ; see also Table 2

T_{oper} (°C)	CATALOGUE NUMBER 2322 615 1.472						
	R_T/R_{25}	TC (%/K)	R_T (Ω)	5% TOL. $\Delta R/R$ (%)	5% TOL. ΔT (K)	10% TOL. $\Delta R/R$ (%)	10% TOL. ΔT (K)
-40	21.9261	-5.75	103053	8.50	1.48	13.66	2.38
-35	16.5224	-5.57	77655	8.16	1.46	13.31	2.39
-30	12.5583	-5.40	59024	7.84	1.45	12.97	2.40
-25	9.62492	-5.24	45237	7.53	1.44	12.65	2.41
-20	7.43618	-5.08	34950	7.23	1.42	12.33	2.43
-15	5.78976	-4.93	27212	6.94	1.41	12.04	2.44
-10	4.54158	-4.78	21345	6.67	1.39	11.75	2.46
-5	3.58813	-4.64	16864	6.40	1.38	11.47	2.47
0	2.85449	-4.51	13416	6.15	1.36	11.20	2.49
5	2.28599	-4.38	10744	5.90	1.35	10.94	2.50
10	1.84245	-4.25	8659.5	5.66	1.33	10.70	2.52
15	1.49414	-4.13	7022.5	5.44	1.32	10.46	2.53
20	1.21887	-4.01	5728.7	5.21	1.30	10.22	2.55
25	1.00	-3.90	4700.0	5.00	1.28	10.00	2.56
30	0.82494	-3.80	3877.2	5.21	1.37	10.22	2.69
35	0.68413	-3.69	3215.4	5.41	1.46	10.43	2.82
40	0.57025	-3.59	2680.2	5.60	1.56	10.63	2.96
45	0.47765	-3.50	2245.0	5.79	1.66	10.83	3.10
50	0.40198	-3.40	1889.3	5.97	1.75	11.02	3.24
55	0.33984	-3.31	1597.2	6.15	1.85	11.20	3.38
60	0.28856	-3.23	1356.2	6.32	1.96	11.38	3.52
65	0.24606	-3.15	1156.5	6.48	2.06	11.55	3.67
70	0.21067	-3.07	990.1	6.64	2.17	11.72	3.82
75	0.18108	-2.99	851.06	6.80	2.28	11.89	3.98
80	0.15623	-2.91	734.29	6.95	2.39	12.05	4.13
85	0.13529	-2.84	635.86	7.10	2.50	12.20	4.29
90	0.11757	-2.77	552.56	7.24	2.61	12.35	4.45
95	0.10251	-2.71	481.81	7.38	2.73	12.50	4.62
100	0.08968	-2.64	421.50	7.52	2.85	12.64	4.78
105	0.07871	-2.58	369.91	7.65	2.97	12.78	4.95
110	0.06928	-2.52	325.64	7.78	3.09	12.91	5.12
115	0.06117	-2.46	287.51	7.91	3.21	13.05	5.30
120	0.05416	-2.41	254.57	8.03	3.34	13.17	5.48
125	0.04809	-2.35	226.03	8.15	3.47	13.30	5.66
130	0.04282	-2.30	201.23	8.27	3.60	13.42	5.84
135	0.03822	-2.25	179.62	8.38	3.73	13.54	6.03
140	0.0342	-2.20	160.73	8.49	3.86	13.66	6.21
145	0.03068	-2.15	144.17	8.60	4.00	13.77	6.40
150	0.02758	-2.10	129.63	8.70	4.14	13.88	6.60

Surface mount NTC thermistors

2322 615 1...

Table 14 Resistance values at intermediate temperatures with R_{25} at 5000 Ω ; see also Table 2

T_{oper} (°C)	CATALOGUE NUMBER 2322 615 1.502						
	R_T/R_{25}	TC (%/K)	R_T (Ω)	5% TOL. $\Delta R/R$ (%)	5% TOL. ΔT (K)	10% TOL. $\Delta R/R$ (%)	10% TOL. ΔT (K)
-40	21.92609	-5.75	109630	8.50	1.48	13.66	2.38
-35	16.52243	-5.57	82612	8.16	1.46	13.31	2.39
-30	12.55825	-5.40	62791	7.84	1.45	12.97	2.40
-25	9.624924	-5.24	48125	7.53	1.44	12.65	2.41
-20	7.43618	-5.08	37181	7.23	1.42	12.33	2.43
-15	5.789764	-4.93	28949	6.94	1.41	12.04	2.44
-10	4.54158	-4.78	22708	6.67	1.39	11.75	2.46
-5	3.58813	-4.64	17941	6.40	1.38	11.47	2.47
0	2.854486	-4.51	14272	6.15	1.36	11.20	2.49
5	2.285986	-4.38	11430	5.90	1.35	10.94	2.50
10	1.842453	-4.25	9212.3	5.66	1.33	10.70	2.52
15	1.494141	-4.13	7470.7	5.44	1.32	10.46	2.53
20	1.218873	-4.01	6094.4	5.21	1.30	10.22	2.55
25	1.00	-3.90	5000.0	5.00	1.28	10.00	2.56
30	0.824942	-3.80	4124.7	5.21	1.37	10.22	2.69
35	0.68413	-3.69	3420.7	5.41	1.46	10.43	2.82
40	0.570246	-3.59	2851.2	5.60	1.56	10.63	2.96
45	0.47765	-3.50	2388.3	5.79	1.66	10.83	3.10
50	0.401981	-3.40	2009.9	5.97	1.75	11.02	3.24
55	0.339838	-3.31	1699.2	6.15	1.85	11.20	3.38
60	0.288561	-3.23	1442.8	6.32	1.96	11.38	3.52
65	0.246057	-3.15	1230.3	6.48	2.06	11.55	3.67
70	0.210668	-3.07	1053.3	6.64	2.17	11.72	3.82
75	0.181077	-2.99	905.39	6.80	2.28	11.89	3.98
80	0.156233	-2.91	781.16	6.95	2.39	12.05	4.13
85	0.135289	-2.84	676.45	7.10	2.50	12.20	4.29
90	0.117567	-2.77	587.83	7.24	2.61	12.35	4.45
95	0.102513	-2.71	512.57	7.38	2.73	12.50	4.62
100	0.089682	-2.64	448.41	7.52	2.85	12.64	4.78
105	0.078705	-2.58	393.53	7.65	2.97	12.78	4.95
110	0.069284	-2.52	346.42	7.78	3.09	12.91	5.12
115	0.061172	-2.46	305.86	7.91	3.21	13.05	5.30
120	0.054164	-2.41	270.82	8.03	3.34	13.17	5.48
125	0.048092	-2.35	240.46	8.15	3.47	13.30	5.66
130	0.042815	-2.30	214.08	8.27	3.60	13.42	5.84
135	0.038216	-2.25	191.08	8.38	3.73	13.54	6.03
140	0.034197	-2.20	170.99	8.49	3.86	13.66	6.21
145	0.030675	-2.15	153.38	8.60	4.00	13.77	6.40
150	0.027581	-2.10	137.90	8.70	4.14	13.88	6.60

Surface mount NTC thermistors

2322 615 1...

Table 15 Resistance values at intermediate temperatures with R_{25} at 10000 Ω ; see also Table 2

T_{oper} (°C)	CATALOGUE NUMBER 2322 615 1.103						
	R_T/R_{25}	TC (%/K)	R_T (Ω)	5% TOL. $\Delta R/R$ (%)	5% TOL. ΔT (K)	10% TOL. $\Delta R/R$ (%)	10% TOL. ΔT (K)
-40	23.0973	-5.84	230973	8.50	1.45	13.72	2.34
-35	17.3222	-5.67	173222	8.16	1.44	13.36	2.35
-30	13.1054	-5.49	131054	7.84	1.43	13.02	2.36
-25	9.99934	-5.33	99993	7.53	1.41	12.69	2.38
-20	7.69193	-5.17	76919	7.23	1.40	12.37	2.39
-15	5.96369	-5.01	59637	6.94	1.38	12.07	2.40
-10	4.6589	-4.86	46589	6.67	1.37	11.78	2.42
-5	3.66623	-4.72	36662	6.40	1.36	11.49	2.43
0	2.9054	-4.58	29054	6.15	1.34	11.22	2.44
5	2.31806	-4.45	23181	5.90	1.33	10.96	2.46
10	1.86153	-4.32	18615.3	5.66	1.31	10.71	2.47
15	1.50429	-4.20	15042.9	5.44	1.29	10.46	2.49
20	1.22295	-4.08	12229.5	5.21	1.28	10.23	2.50
25	1.00	-3.97	10000.0	5.00	1.26	10.00	2.52
30	0.82227	-3.86	8222.7	5.21	1.35	10.22	2.65
35	0.67977	-3.75	6797.7	5.41	1.44	10.43	2.78
40	0.56487	-3.65	5648.7	5.60	1.53	10.64	2.91
45	0.47174	-3.55	4717.4	5.79	1.63	10.84	3.05
50	0.39585	-3.46	3958.5	5.97	1.72	11.03	3.19
55	0.33371	-3.37	3337.1	6.15	1.82	11.22	3.33
60	0.28258	-3.28	2825.8	6.32	1.92	11.40	3.47
65	0.24031	-3.20	2403.1	6.48	2.03	11.58	3.62
70	0.20521	-3.12	2052.1	6.64	2.13	11.75	3.77
75	0.17594	-3.04	1759.37	6.80	2.24	11.92	3.92
80	0.15142	-2.96	1514.20	6.95	2.35	12.08	4.08
85	0.1308	-2.89	1308.04	7.10	2.46	12.24	4.24
90	0.1134	-2.82	1134.00	7.24	2.57	12.39	4.40
95	0.09865	-2.75	986.53	7.38	2.68	12.54	4.56
100	0.08611	-2.69	861.10	7.52	2.80	12.68	4.72
105	0.0754	-2.62	754.04	7.65	2.92	12.83	4.89
110	0.06624	-2.56	662.36	7.78	3.04	12.96	5.06
115	0.05836	-2.50	583.58	7.91	3.16	13.10	5.24
120	0.05157	-2.45	515.67	8.03	3.28	13.23	5.41
125	0.4569	-2.39	456.94	8.15	3.41	13.35	5.59
130	0.0406	-2.34	406.01	8.27	3.54	13.48	5.77
135	0.03617	-2.29	361.71	8.38	3.67	13.60	5.96
140	0.03231	-2.23	323.06	8.49	3.80	13.72	6.15
145	0.02893	-2.19	289.26	8.60	3.93	13.83	6.34
150	0.02596	-2.14	259.61	8.70	4.07	13.95	6.53

Surface mount NTC thermistors

2322 615 1...

Table 16 Resistance values at intermediate temperatures with R_{25} at 15000 Ω ; see also Table 2

T_{oper} (°C)	CATALOGUE NUMBER 2322 615 1.153						
	R_T/R_{25}	TC (%/K)	R_T (Ω)	5% TOL. $\Delta R/R$ (%)	5% TOL. ΔT (K)	10% TOL. $\Delta R/R$ (%)	10% TOL. ΔT (K)
-40	23.3421	-6.06	350131	8.46	1.40	13.63	2.25
-35	17.336	-5.84	260040	8.13	1.39	13.28	2.27
-30	13.0176	-5.62	195263	7.81	1.39	12.94	2.30
-25	9.87717	-5.42	148158	7.50	1.38	12.62	2.33
-20	7.56881	-5.23	113532	7.21	1.38	12.31	2.36
-15	5.8546	-5.05	87819	6.93	1.37	12.02	2.38
-10	4.56918	-4.87	68538	6.65	1.37	11.73	2.41
-5	3.59635	-4.71	53945	6.39	1.36	11.46	2.43
0	2.85356	-4.55	42803	6.14	1.35	11.19	2.46
5	2.28163	-4.40	34224	5.89	1.34	10.94	2.49
10	1.83772	-4.26	27566	5.66	1.33	10.69	2.51
15	1.49054	-4.12	22358	5.43	1.32	10.45	2.54
20	1.21701	-3.99	18255	5.21	1.31	10.22	2.56
25	1.00	-3.87	15000	5.00	1.29	10.00	2.59
30	0.83154	-3.75	12473	5.20	1.39	10.21	2.73
35	0.69408	-3.63	10411	5.40	1.49	10.42	2.87
40	0.58149	-3.53	8722.3	5.60	1.59	10.62	3.01
45	0.48893	-3.42	7334.0	5.78	1.69	10.82	3.16
50	0.41256	-3.32	6188.5	5.96	1.79	11.01	3.31
55	0.34933	-3.23	5240.0	6.14	1.90	11.19	3.47
60	0.2968	-3.14	4451.9	6.31	2.01	11.37	3.62
65	0.253	-3.05	3794.9	6.47	2.12	11.54	3.78
70	0.21635	-2.97	3245.3	6.63	2.24	11.71	3.95
75	0.1856	-2.89	2784.0	6.78	2.35	11.87	4.11
80	0.15971	-2.81	2395.7	6.94	2.47	12.03	4.28
85	0.13785	-2.73	2067.7	7.08	2.59	12.18	4.46
90	0.11932	-2.66	1789.8	7.22	2.71	12.33	4.63
95	0.10358	-2.59	1553.7	7.36	2.84	12.47	4.81
100	0.09016	-2.53	1352.4	7.50	2.97	12.62	4.99
105	0.0787	-2.46	1180.5	7.63	3.10	12.75	5.18
110	0.06887	-2.40	1033.1	7.76	3.23	12.89	5.36
115	0.06043	-2.34	906.41	7.88	3.36	13.02	5.56
120	0.05315	-2.29	797.27	8.00	3.50	13.15	5.75
125	0.04687	-2.23	702.99	8.12	3.64	13.27	5.95
130	0.04142	-2.18	621.33	8.24	3.78	13.39	6.15
135	0.03669	-2.13	550.42	8.35	3.92	13.51	6.35
140	0.03258	-2.08	488.72	8.46	4.07	13.62	6.56
145	0.02899	-2.03	434.88	8.57	4.22	13.74	6.77
150	0.02585	-1.98	387.81	8.67	4.37	13.85	6.98

Surface mount NTC thermistors

2322 615 1...

Table 17 Resistance values at intermediate temperatures with R_{25} at 22000 Ω ; see also Table 2

T_{oper} (°C)	CATALOGUE NUMBER 2322 615 1.223						
	R_T/R_{25}	TC (%/K)	R_T (Ω)	5% TOL. $\Delta R/R$ (%)	5% TOL. ΔT (K)	10% TOL. $\Delta R/R$ (%)	10% TOL. ΔT (K)
-40	30.7958	-6.42	677507.99	16.71	2.60	22.27	3.47
-35	22.4562	-6.21	494036.94	15.59	2.51	21.09	3.39
-30	16.5404	-6.02	363888.31	14.50	2.41	19.96	3.32
-25	12.3010	-5.83	270622.69	13.47	2.31	18.87	3.24
-20	9.2333	-5.65	203131.71	12.47	2.21	17.82	3.16
-15	6.9923	-5.47	153831.44	11.51	2.10	16.82	3.07
-10	5.3406	-5.31	117492.27	10.59	2.00	15.85	2.99
-5	4.1124	-5.15	90473.18	9.70	1.88	14.92	2.90
0	3.1916	-4.99	70215.46	8.85	1.77	14.03	2.81
5	2.4957	-4.85	54904.79	8.02	1.66	13.17	2.72
10	1.9656	-4.70	43243.49	7.23	1.54	12.33	2.62
15	1.5589	-4.57	34295.62	6.46	1.41	11.53	2.52
20	1.2446	-4.44	27380.67	5.72	1.29	10.75	2.42
25	1.0000	-4.31	22000.00	5.00	1.16	10.00	2.32
30	0.8084	-4.19	17785.47	5.69	1.36	10.73	2.56
35	0.6574	-4.08	14463.33	6.36	1.56	11.43	2.80
40	0.5377	-3.97	11828.57	7.01	1.77	12.11	3.05
45	0.4421	-3.86	9726.63	7.64	1.98	12.77	3.31
50	0.3655	-3.76	8040.24	8.25	2.20	13.41	3.57
55	0.3036	-3.66	6679.83	8.84	2.42	14.02	3.83
60	0.2535	-3.56	5576.61	9.41	2.64	14.62	4.10
65	0.2126	-3.47	4677.41	9.97	2.87	15.21	4.38
70	0.1791	-3.38	3940.90	10.51	3.11	15.77	4.66
75	0.1516	-3.30	3334.80	11.03	3.35	16.32	4.95
80	0.1288	-3.22	2833.74	11.54	3.59	16.86	5.24
85	0.1099	-3.14	2417.69	12.04	3.84	17.37	5.54
90	0.0941	-3.06	2070.77	12.52	4.09	17.88	5.84
95	0.0809	-2.99	1780.29	12.99	4.35	18.37	6.15
100	0.0698	-2.92	1536.11	13.45	4.61	18.85	6.47
105	0.0605	-2.85	1330.07	13.89	4.88	19.31	6.79
110	0.0525	-2.78	1155.56	14.32	5.15	19.77	7.11
115	0.0458	-2.72	1007.23	14.74	5.43	20.21	7.44
120	0.0400	-2.65	880.71	15.15	5.71	20.64	7.78
125	0.0351	-2.59	772.44	15.55	6.00	21.06	8.12
130	0.0309	-2.54	679.48	15.94	6.29	21.46	8.46
135	0.0272	-2.48	599.41	16.32	6.58	21.86	8.82
140	0.0241	-2.43	530.24	16.70	6.88	22.25	9.18
145	0.0214	-2.37	470.31	17.06	7.19	22.63	9.54
150	0.0190	-2.32	418.23	17.41	7.50	23.00	9.91

Surface mount NTC thermistors

2322 615 1...

Table 18 Resistance values at intermediate temperatures with R_{25} at 33000 Ω ; see also Table 2

T_{oper} (°C)	CATALOGUE NUMBER 2322 615 1.333						
	R_T/R_{25}	TC (%/K)	R_T (Ω)	5% TOL. $\Delta R/R$ (%)	5% TOL. ΔT (K)	10% TOL. $\Delta R/R$ (%)	10% TOL. ΔT (K)
-40	32.68563	-6.59	1078626	16.66	2.53	22.22	3.37
-35	23.6478	-6.36	780377	15.54	2.44	21.04	3.31
-30	17.29545	-6.15	570750	14.46	2.35	19.91	3.24
-25	12.78101	-5.95	421773	13.43	2.26	18.83	3.17
-20	9.538645	-5.76	314775	12.44	2.16	17.79	3.09
-15	7.186265	-5.57	237147	11.48	2.06	16.79	3.01
-10	5.463007	-5.40	180279	10.56	1.96	15.83	2.93
-5	4.18889	-5.23	138233	9.68	1.85	14.90	2.85
0	3.238476	-5.07	106870	8.83	1.74	14.01	2.77
5	2.523488	-4.91	83275	8.01	1.63	13.15	2.68
10	1.9812223	-4.77	65380.4	7.22	1.51	12.32	2.59
15	1.566743	-4.62	51702.5	6.45	1.40	11.52	2.49
20	1.247561	-4.49	41169.5	5.71	1.27	10.75	2.39
25	1.00	-4.36	33000.0	5.00	1.15	10.00	2.29
30	0.806666	-4.24	26620.0	5.69	1.34	10.72	2.53
35	0.654682	-4.12	21604.5	6.36	1.54	11.42	2.78
40	0.534445	-4.00	17636.7	7.00	1.75	12.10	3.02
45	0.438742	-3.89	14478.5	7.63	1.96	12.76	3.28
50	0.362121	-3.79	11950.0	8.24	2.18	13.39	3.54
55	0.30043	-3.68	9914.2	8.82	2.39	14.01	3.80
60	0.250491	-3.59	8266.2	9.40	2.62	14.60	4.07
65	0.209854	-3.49	6925.2	9.95	2.85	15.18	4.35
70	0.17662	-3.40	5828.5	10.49	3.08	15.75	4.63
75	0.149308	-3.32	4927.18	11.01	3.32	16.29	4.91
80	0.126759	-3.23	4183.06	11.52	3.56	16.83	5.20
85	0.108058	-3.15	3565.93	12.01	3.81	17.34	5.50
90	0.092482	-3.07	3051.89	12.49	4.06	17.85	5.80
95	0.079453	-3.00	2621.93	12.96	4.32	18.33	6.11
100	0.068511	-2.93	2260.85	13.41	4.58	18.81	6.43
105	0.059286	-2.86	1956.42	13.85	4.85	19.27	6.74
110	0.051479	-2.79	1698.80	14.28	5.12	19.72	7.07
115	0.044848	-2.73	1479.98	14.70	5.39	20.16	7.40
120	0.039196	-2.66	1293.47	15.11	5.67	20.59	7.73
125	0.034363	-2.60	1133.96	15.51	5.96	21.01	8.07
130	0.030215	-2.54	997.09	15.90	6.25	21.42	8.42
135	0.026645	-2.49	879.28	16.28	6.55	21.81	8.77
140	0.023562	-2.43	777.55	16.65	6.84	22.20	9.13
145	0.020892	-2.38	689.45	17.01	7.15	22.58	9.49
150	0.018573	-2.33	612.93	17.36	7.46	22.95	9.86

Surface mount NTC thermistors

2322 615 1...

Table 19 Resistance values at intermediate temperatures with R_{25} at 47000 Ω ; see also Table 2

T_{oper} (°C)	CATALOGUE NUMBER 2322 615 1.473						
	R_T/R_{25}	TC (%/K)	R_T (Ω)	5% TOL. $\Delta R/R$ (%)	5% TOL. ΔT (K)	10% TOL. $\Delta R/R$ (%)	10% TOL. ΔT (K)
-40	37.156	-6.82	1746331	11.02	1.62	16.31	2.39
-35	26.5657	-6.60	1248589	10.44	1.58	15.70	2.38
-30	19.2065	-6.38	902705	9.89	1.55	15.12	2.37
-25	14.0347	-6.17	659632	9.35	1.52	14.56	2.36
-20	10.3608	-5.97	486956	8.84	1.48	14.02	2.35
-15	7.72365	-5.78	363012	8.35	1.44	13.51	2.34
-10	5.81188	-5.60	273158	7.87	1.41	13.01	2.32
-5	4.41266	-5.42	207395	7.42	1.37	12.53	2.31
0	3.37917	-5.25	158821	6.98	1.33	12.07	2.30
5	2.60609	-5.09	122627	6.55	1.29	11.63	2.28
10	2.03042	-4.94	95430	6.14	1.24	11.20	2.27
15	1.59206	-4.79	74827	5.75	1.20	10.79	2.25
20	1.2574	-4.65	59098	5.37	1.15	10.39	2.23
25	1.00	-4.51	47000	5.00	1.11	10.00	2.22
30	0.8006	-4.38	37628	5.36	1.22	10.37	2.37
35	0.64506	-4.26	30318	5.70	1.34	10.73	2.52
40	0.52294	-4.14	24578	6.04	1.46	11.08	2.68
45	0.42644	-4.02	20043	6.36	1.58	11.42	2.84
50	0.34971	-3.91	16437	6.67	1.71	11.75	3.00
55	0.28836	-3.81	13553	6.98	1.83	12.07	3.17
60	0.23901	-3.70	11233	7.27	1.96	12.38	3.34
65	0.1991	-3.60	9358	7.56	2.10	12.68	3.52
70	0.16666	-3.51	7833	7.83	2.23	12.97	3.69
75	0.14016	-3.42	6587	8.10	2.37	13.25	3.88
80	0.1184	-3.33	5565	8.37	2.51	13.53	4.06
85	0.10045	-3.25	4721	8.62	2.66	13.79	4.25
90	0.08557	-3.16	4022	8.87	2.80	14.05	4.44
95	0.07319	-3.09	3440	9.11	2.95	14.30	4.64
100	0.06285	-3.01	2954	9.34	3.10	14.55	4.83
105	0.05416	-2.94	2546	9.57	3.26	14.79	5.04
110	0.04685	-2.87	2202	9.79	3.42	15.02	5.24
115	0.04066	-2.80	1911	10.01	3.58	15.25	5.45
120	0.03541	-2.73	1664	10.22	3.74	15.47	5.66
125	0.03094	-2.67	1454	10.43	3.91	15.69	5.88
130	0.02711	-2.61	1274	10.63	4.08	15.90	6.10
135	0.02383	-2.55	1120	10.82	4.25	16.10	6.32
140	0.02101	-2.49	987.6	11.02	4.42	16.30	6.54
145	0.01858	-2.44	873.2	11.20	4.60	16.50	6.77
150	0.01647	-2.38	774.1	11.38	4.78	16.69	7.01

Surface mount NTC thermistors

2322 615 1...

Table 20 Resistance values at intermediate temperatures with R_{25} at 68000 Ω ; see also Table 2

T_{oper} (°C)	CATALOGUE NUMBER 2322 615 1.683						
	R_T/R_{25}	TC (%/K)	R_T (Ω)	5% TOL. $\Delta R/R$ (%)	5% TOL. ΔT (K)	10% TOL. $\Delta R/R$ (%)	10% TOL. ΔT (K)
-40	25.783	-6.07	1753245	16.02	2.64	21.54	3.55
-35	19.1253	-5.88	1300524	14.96	2.54	20.43	3.47
-30	14.32	-5.70	973759.8	13.94	2.45	19.36	3.40
-25	10.8187	-5.52	735674.7	12.96	2.35	18.34	3.32
-20	8.24438	-5.35	560618	12.02	2.25	17.36	3.24
-15	6.33489	-5.19	430772.3	11.12	2.14	16.41	3.16
-10	4.90655	-5.03	333645.6	10.26	2.04	15.51	3.08
-5	3.82943	-4.88	260401.1	9.42	1.93	14.63	3.00
0	3.01078	-4.74	204733.3	8.62	1.82	13.79	2.91
5	2.3839	-4.60	162105	7.84	1.70	12.98	2.82
10	1.90036	-4.47	129224.7	7.09	1.59	12.19	2.73
15	1.52479	-4.34	103686	6.37	1.47	11.44	2.63
20	1.23112	-4.22	83716.26	5.67	1.35	10.71	2.54
25	1.00	-4.10	68000	5.00	1.22	10.00	2.44
30	0.81697	-3.99	55554.14	5.65	1.42	10.68	2.68
35	0.67116	-3.88	45638.98	6.28	1.62	11.34	2.93
40	0.55433	-3.77	37694.27	6.89	1.83	11.98	3.18
45	0.46019	-3.67	31292.96	7.48	2.04	12.60	3.43
50	0.38393	-3.58	26107.56	8.06	2.25	13.20	3.69
55	0.32184	-3.48	21885.36	8.61	2.47	13.78	3.96
60	0.27103	-3.39	18430.3	9.15	2.70	14.35	4.23
65	0.22926	-3.30	15589.41	9.67	2.93	14.90	4.51
70	0.19475	-3.22	13242.67	10.18	3.16	15.43	4.79
75	0.16611	-3.14	11295.44	10.67	3.40	15.95	5.08
80	0.14225	-3.06	9672.73	11.15	3.64	16.45	5.37
85	0.12228	-2.99	8314.81	11.62	3.89	16.93	5.67
90	0.1055	-2.92	7173.88	12.07	4.14	17.41	5.97
95	0.09135	-2.85	6211.55	12.51	4.40	17.87	6.28
100	0.07936	-2.78	5396.80	12.94	4.66	18.32	6.59
105	0.06918	-2.71	4704.48	13.36	4.92	18.76	6.91
110	0.0605	-2.65	4114.12	13.77	5.19	19.18	7.24
115	0.05307	-2.59	3609	14.16	5.47	19.60	7.57
120	0.0467	-2.53	3175.38	14.55	5.75	20.00	7.90
125	0.04121	-2.47	2801.96	14.92	6.03	20.40	8.24
130	0.03646	-2.42	2479.38	15.29	6.32	20.78	8.59
135	0.03235	-2.37	2199.88	15.65	6.62	21.16	8.94
140	0.02878	-2.31	1957.02	16.00	6.91	21.52	9.30
145	0.02567	-2.26	1745.39	16.34	7.22	21.88	9.66
150	0.02295	-2.22	1560.48	16.67	7.52	22.23	10.03

Surface mount NTC thermistors

2322 615 1...

Table 21 Resistance values at intermediate temperatures with R_{25} at 100000 Ω ; see also Table 2

T_{oper} (°C)	CATALOGUE NUMBER 2322 615 1.104						
	R_T/R_{25}	TC (%/K)	R_T (Ω)	5% TOL. $\Delta R/R$ (%)	5% TOL. ΔT (K)	10% TOL. $\Delta R/R$ (%)	10% TOL. ΔT (K)
-40	23.8997	-5.92	2389969	8.58	1.45	13.72	2.32
-35	17.8586	-5.74	1785861	8.24	1.44	13.36	2.33
-30	13.465	-5.56	1346502	7.91	1.42	13.02	2.34
-25	10.2407	-5.39	1024071	7.59	1.41	12.69	2.35
-20	7.85378	-5.23	785378.1	7.28	1.39	12.37	2.37
-15	6.07181	-5.07	607181.2	6.99	1.38	12.07	2.38
-10	4.73061	-4.92	473061.1	6.71	1.36	11.78	2.40
-5	3.7132	-4.77	371319.7	6.44	1.35	11.49	2.41
0	2.93554	-4.63	293553.6	6.18	1.33	11.22	2.42
5	2.33677	-4.50	233677.1	5.92	1.32	10.96	2.44
10	1.87249	-4.37	187249.2	5.68	1.30	10.71	2.45
15	1.51004	-4.24	151003.9	5.45	1.28	10.46	2.47
20	1.22522	-4.12	122522.4	5.22	1.27	10.23	2.48
25	1.00	-4.01	100000	5.00	1.25	10.00	2.50
30	0.82081	-3.89	82081.36	5.21	1.34	10.22	2.62
35	0.67742	-3.79	67741.67	5.42	1.43	10.43	2.76
40	0.56201	-3.68	56201.1	5.62	1.52	10.64	2.89
45	0.46863	-3.59	46862.56	5.81	1.62	10.84	3.02
50	0.39266	-3.49	39266.09	5.99	1.72	11.03	3.16
55	0.33055	-3.40	33055.34	6.18	1.82	11.22	3.30
60	0.27953	-3.31	27952.66	6.35	1.92	11.40	3.45
65	0.23741	-3.22	23740.56	6.52	2.02	11.58	3.59
70	0.20248	-3.14	20247.74	6.69	2.13	11.75	3.74
75	0.17339	-3.06	17338.63	6.85	2.24	11.92	3.89
80	0.14905	-2.99	14905.37	7.00	2.34	12.08	4.05
85	0.12862	-2.91	12861.77	7.15	2.46	12.24	4.20
90	0.11139	-2.84	11138.64	7.30	2.57	12.39	4.36
95	0.0968	-2.77	9680.13	7.44	2.68	12.54	4.52
100	0.08441	-2.71	8441.05	7.58	2.80	12.68	4.69
105	0.07385	-2.64	7384.60	7.72	2.92	12.83	4.85
110	0.06481	-2.58	6480.76	7.85	3.04	12.96	5.02
115	0.05705	-2.52	5704.87	7.98	3.17	13.10	5.20
120	0.05037	-2.46	5036.67	8.11	3.29	13.23	5.37
125	0.04459	-2.41	4459.40	8.23	3.42	13.35	5.55
130	0.03959	-2.35	3959.18	8.35	3.55	13.48	5.73
135	0.03524	-2.30	3524.43	8.46	3.68	13.60	5.91
140	0.03146	-2.25	3145.52	8.58	3.81	13.72	6.10
145	0.02814	-2.20	2814.35	8.69	3.95	13.83	6.29
150	0.02524	-2.15	2524.15	8.80	4.09	13.95	6.48

Surface mount NTC thermistors

2322 615 1...

Table 22 Resistance values at intermediate temperatures with R_{25} at 150000 Ω ; see also Table 2

T_{oper} (°C)	CATALOGUE NUMBER 2322 615 1.154						
	R_T/R_{25}	TC (%/K)	R_T (k Ω)	5% TOL. $\Delta R/R$ (%)	5% TOL. ΔT (K)	10% TOL. $\Delta R/R$ (%)	10% TOL. ΔT (K)
-40	27.4500	-6.19	4117.5	16.21	2.62	21.75	3.51
-35	20.2394	-6.00	3035.9	15.13	2.52	20.62	3.44
-30	15.0667	-5.81	2260.0	14.10	2.43	19.53	3.36
-25	11.3199	-5.63	1698.0	13.10	2.33	18.49	3.28
-20	8.5804	-5.46	1287.1	12.15	2.23	17.49	3.21
-15	6.5594	-5.29	983.9	11.23	2.12	16.53	3.13
-10	5.0554	-5.13	758.3	10.35	2.02	15.60	3.04
-5	3.9269	-4.98	589.0	9.50	1.91	14.71	2.96
0	3.0733	-4.83	461.0	8.68	1.80	13.86	2.87
5	2.4227	-4.69	363.41	7.89	1.68	13.03	2.78
10	1.9231	-4.55	288.47	7.13	1.57	12.23	2.69
15	1.5367	-4.42	230.51	6.40	1.45	11.46	2.59
20	1.2358	-4.30	185.38	5.69	1.32	10.72	2.50
25	1.0000	-4.18	150.00	5.00	1.20	10.00	2.39
30	0.8140	-4.06	122.09	5.66	1.40	10.69	2.63
35	0.6663	-3.95	99.94	6.31	1.60	11.37	2.88
40	0.5484	-3.84	82.26	6.93	1.80	12.02	3.13
45	0.4537	-3.74	68.06	7.53	2.01	12.65	3.38
50	0.3773	-3.64	56.60	8.11	2.23	13.26	3.64
55	0.3153	-3.54	47.29	8.68	2.45	13.85	3.91
60	0.2647	-3.45	39.71	9.23	2.67	14.43	4.18
65	0.2232	-3.36	33.49	9.76	2.90	14.98	4.45
70	0.1891	-3.28	28.36	10.27	3.13	15.53	4.74
75	0.1608	-3.20	24.13	10.78	3.37	16.05	5.02
80	0.1374	-3.12	20.60	11.26	3.61	16.56	5.31
85	0.1178	-3.04	17.66	11.74	3.86	17.06	5.61
90	0.1013	-2.97	15.20	12.20	4.11	17.54	5.91
95	0.0875	-2.90	13.13	12.65	4.37	18.01	6.22
100	0.0759	-2.83	11.38	13.08	4.63	18.47	6.53
105	0.0660	-2.76	9.90	13.51	4.89	18.91	6.85
110	0.0576	-2.70	8.63	13.92	5.16	19.35	7.18
115	0.0504	-2.63	7.56	14.33	5.44	19.77	7.51
120	0.0442	-2.57	6.63	14.72	5.72	20.18	7.84
125	0.0389	-2.52	5.84	15.10	6.00	20.58	8.18
130	0.0344	-2.46	5.158	15.48	6.29	20.97	8.53
135	0.0305	-2.41	4.568	15.84	6.58	21.36	8.88
140	0.0270	-2.35	4.055	16.20	6.88	21.73	9.23
145	0.0241	-2.30	3.610	16.54	7.19	22.09	9.60
150	0.0215	-2.25	3.221	16.88	7.49	22.45	9.96

Surface mount NTC thermistors

2322 615 1...

Table 23 Resistance values at intermediate temperatures with R_{25} at 330000 Ω ; see also Table 2

T_{oper} (°C)	CATALOGUE NUMBER 2322 615 1.334						
	R_T/R_{25}	TC (%/K)	R_T (k Ω)	5% TOL. $\Delta R/R$ (%)	5% TOL. ΔT (K)	10% TOL. $\Delta R/R$ (%)	10% TOL. ΔT (K)
-40	33.3434	-6.58	11 003.3	16.83	2.56	22.39	3.40
-35	24.1285	-6.36	7962.4	15.69	2.46	21.20	3.33
-30	17.6422	-6.16	5821.9	14.60	2.37	21.05	3.25
-25	13.0283	-5.97	4299.4	13.55	2.27	18.95	3.18
-20	9.7132	-5.78	3205.4	12.54	2.17	17.90	3.10
-15	7.3081	-5.60	2411.7	11.57	2.07	16.89	3.01
-10	5.5470	-5.43	1830.5	10.64	1.96	15.91	2.93
-5	4.2457	-5.27	1401.1	9.75	1.85	14.97	2.84
0	3.2760	-5.11	1081.1	8.88	1.74	14.07	2.75
5	2.5474	-4.96	840.63	8.05	1.62	13.20	2.66
10	1.9955	-4.81	658.52	7.25	1.51	12.35	2.57
15	1.5744	-4.67	519.55	6.47	1.39	11.54	2.47
20	1.2506	-4.54	412.71	5.72	1.26	10.76	2.37
25	1.0000	-4.41	330.00	5.00	1.13	10.00	2.27
30	0.8046	-4.29	265.53	5.70	1.33	10.73	2.50
35	0.6514	-4.17	214.95	6.38	1.53	11.44	2.75
40	0.5304	-4.05	175.02	7.03	1.73	12.13	2.99
45	0.4343	-3.94	143.31	7.67	1.94	12.79	3.24
50	0.3575	-3.84	117.97	8.28	2.16	13.44	3.50
55	0.2958	-3.74	97.62	8.88	2.36	14.06	3.76
60	0.2460	-3.64	81.18	9.46	2.60	14.67	4.03
65	0.2056	-3.55	67.83	10.02	2.83	15.26	4.30
70	0.1726	-3.45	56.94	10.56	3.06	15.83	4.58
75	0.1455	-3.37	48.02	11.09	3.29	16.38	4.86
80	0.1232	-3.28	40.66	11.61	3.53	16.92	5.15
85	0.1048	-3.20	34.57	12.11	3.78	17.44	5.45
90	0.0894	-3.12	29.52	12.59	4.03	17.95	5.75
95	0.0767	-3.05	25.30	13.07	4.29	18.45	6.05
100	0.0659	-2.98	21.76	13.53	4.54	18.93	6.36
105	0.0569	-2.91	18.78	13.97	4.81	19.40	6.68
110	0.0493	-2.84	16.27	14.41	5.08	19.86	7.00
115	0.0429	-2.77	14.14	14.84	5.35	20.30	7.32
120	0.0374	-2.71	12.33	15.25	5.63	20.74	7.66
125	0.0327	-2.65	10.79	15.65	5.91	21.16	7.99
130	0.0287	-2.59	9.463	16.05	6.20	21.57	8.34
135	0.0252	-2.53	8.326	16.43	6.49	21.98	8.68
140	0.0223	-2.48	7.347	16.81	6.79	22.37	9.04
145	0.0197	-2.42	6.500	17.17	7.09	22.75	9.40
150	0.0175	-2.37	5.767	17.53	7.40	22.13	9.76

Surface mount NTC thermistors

2322 615 1...

Table 24 Resistance values at intermediate temperatures with R_{25} at 470000 Ω ; see also Table 2

T_{oper} (°C)	CATALOGUE NUMBER 2322 615 1.474						
	R_T/R_{25}	TC (%/K)	R_T (k Ω)	5% TOL. $\Delta R/R$ (%)	5% TOL. ΔT (K)	10% TOL. $\Delta R/R$ (%)	10% TOL. ΔT (K)
-40	37.1288	-6.79	17450.5	17.16	2.53	22.74	3.35
-35	26.5910	-6.57	12497.8	15.99	2.44	21.52	3.28
-30	19.2505	-6.36	9047.8	14.87	2.34	20.34	3.20
-25	14.0812	-6.15	6618.2	13.79	2.24	19.21	3.12
-20	10.4026	-5.96	4889.2	12.76	2.14	18.13	3.04
-15	7.7582	-5.77	3646.4	11.76	2.04	17.08	2.96
-10	5.8389	-5.60	2744.3	10.80	1.93	16.08	2.87
-5	4.4329	-5.43	2083.5	9.88	1.82	15.11	2.79
0	3.3937	-5.26	1595.0	8.99	1.71	14.18	2.70
5	2.6190	-5.10	1230.93	8.14	1.59	13.29	2.60
10	2.0367	-4.95	957.26	7.31	1.48	12.42	2.51
15	1.5956	-4.81	749.94	6.51	1.35	11.59	2.41
20	1.2589	-4.67	591.68	5.74	1.23	10.78	2.31
25	1.0000	-4.54	470.00	5.00	1.10	10.00	2.20
30	0.7995	-4.41	375.78	5.72	1.30	10.75	2.44
35	0.6433	-4.29	302.34	6.42	1.50	11.48	2.68
40	0.5207	-4.17	244.71	7.09	1.70	12.19	2.92
45	0.4239	-4.06	199.22	7.74	1.91	12.87	3.17
50	0.3470	-3.95	163.08	8.38	2.12	13.54	3.43
55	0.2856	-3.84	134.22	8.99	2.34	14.18	3.69
60	0.2362	-3.74	111.03	9.58	2.56	14.80	3.95
65	0.1964	-3.65	92.30	10.16	2.79	15.41	4.23
70	0.1640	-3.55	77.10	10.72	3.02	15.99	4.50
75	0.1377	-3.46	64.70	11.27	3.25	16.56	4.78
80	0.1160	-3.38	54.53	11.80	3.49	17.12	5.07
85	0.0982	-3.29	46.16	12.31	3.74	17.66	5.36
90	0.0835	-3.21	39.23	12.81	3.99	18.18	5.66
95	0.0712	-3.13	33.48	13.30	4.24	18.69	5.96
100	0.0610	-3.06	28.68	13.77	4.50	19.19	6.27
105	0.0525	-2.99	24.66	14.23	4.77	19.67	6.59
110	0.0453	-2.92	21.27	14.68	5.03	20.14	6.91
115	0.0392	-2.85	18.42	15.12	5.31	20.60	7.23
120	0.0340	-2.78	16.00	15.54	5.58	21.05	7.56
125	0.0297	-2.72	13.94	15.96	5.87	21.48	7.90
130	0.0259	-2.66	12.189	16.36	6.15	21.91	8.24
135	0.0227	-2.60	10.688	16.76	6.45	22.32	8.59
140	0.0200	-2.54	9.398	17.15	6.74	22.72	8.94
145	0.0176	-2.49	8.288	17.52	7.05	23.12	9.30
150	0.0156	-2.43	7.329	17.89	7.35	23.50	9.66