

REVISIONS				
P	LTN	DESCRIPTION	DATE	APVD
A		RELEASED PER ECO-19-014774	26SEP2019	CJV JW
B		REVISED PER ECN-21-126523	14MAR2022	TX DZ
C		REVISED PER ECN-22-153747	26MAY2022	TX DZ
C1		REVISED PER ECN-22-177902	07OCT2022	TM DZ

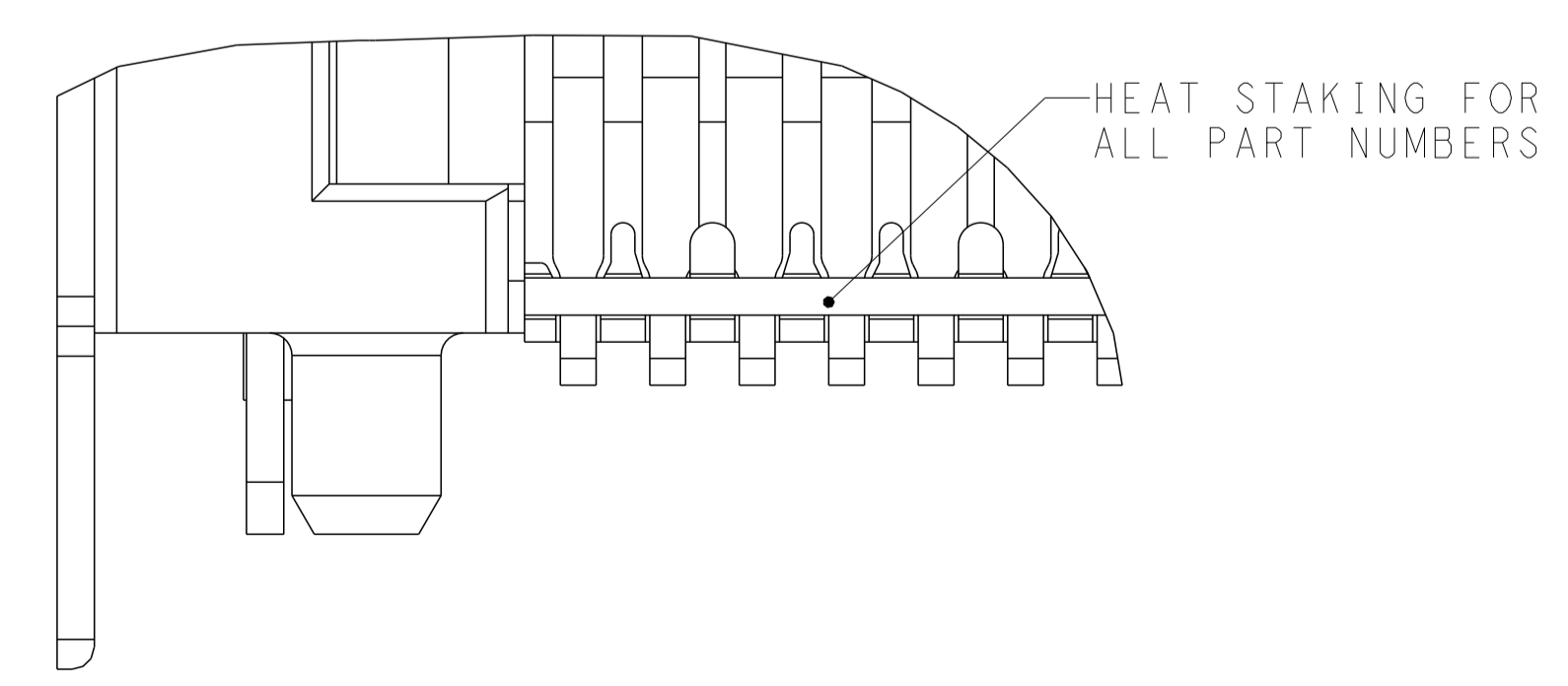
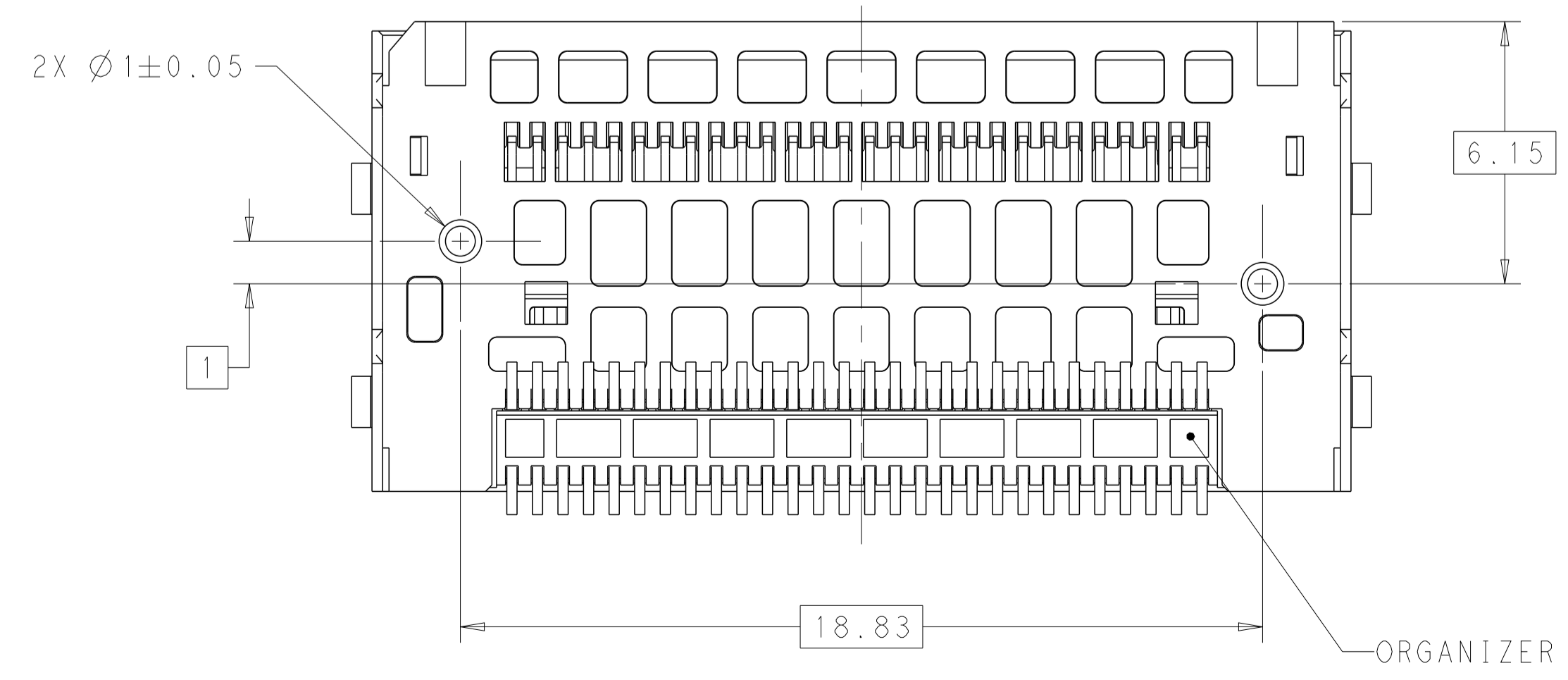
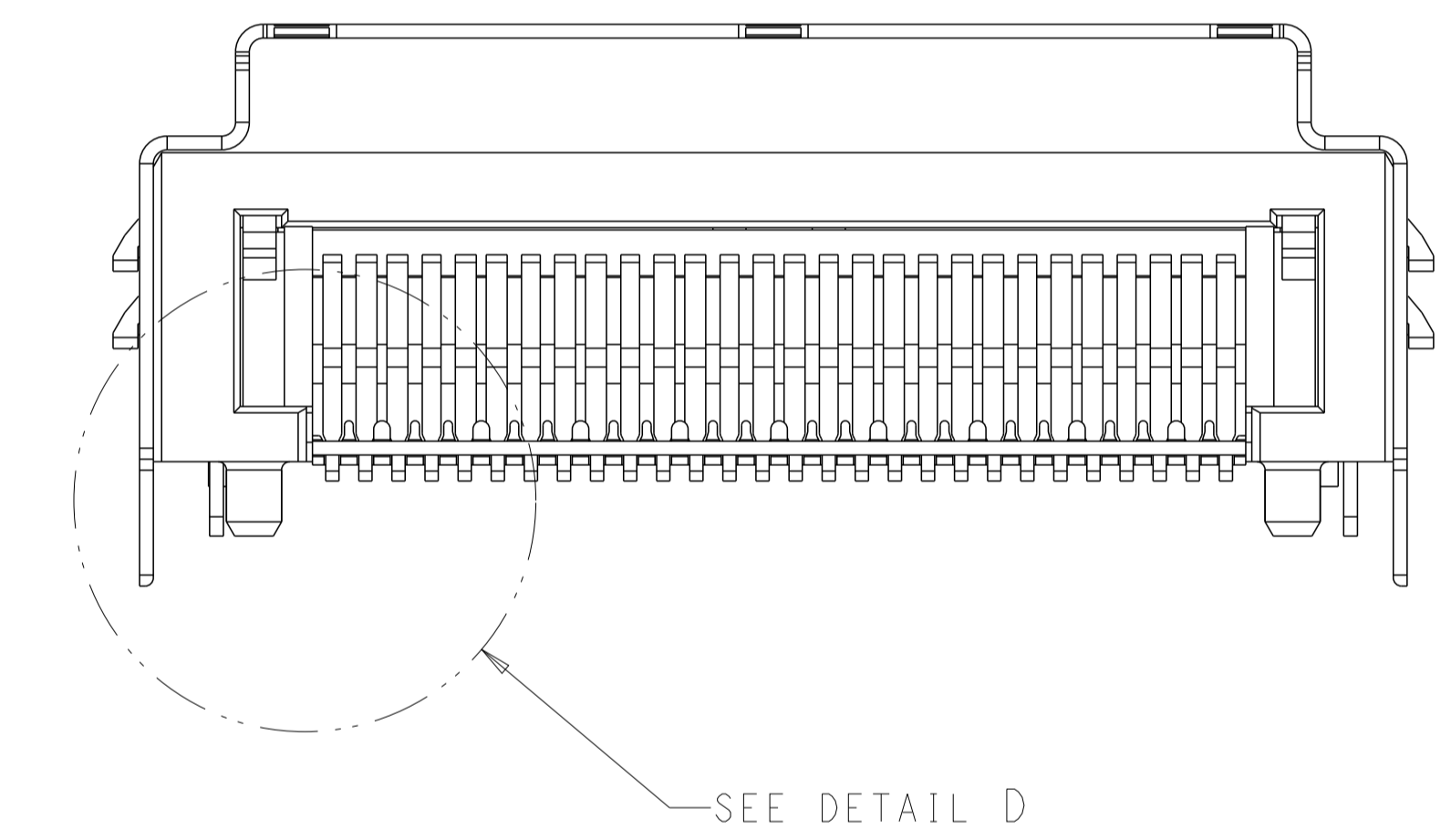
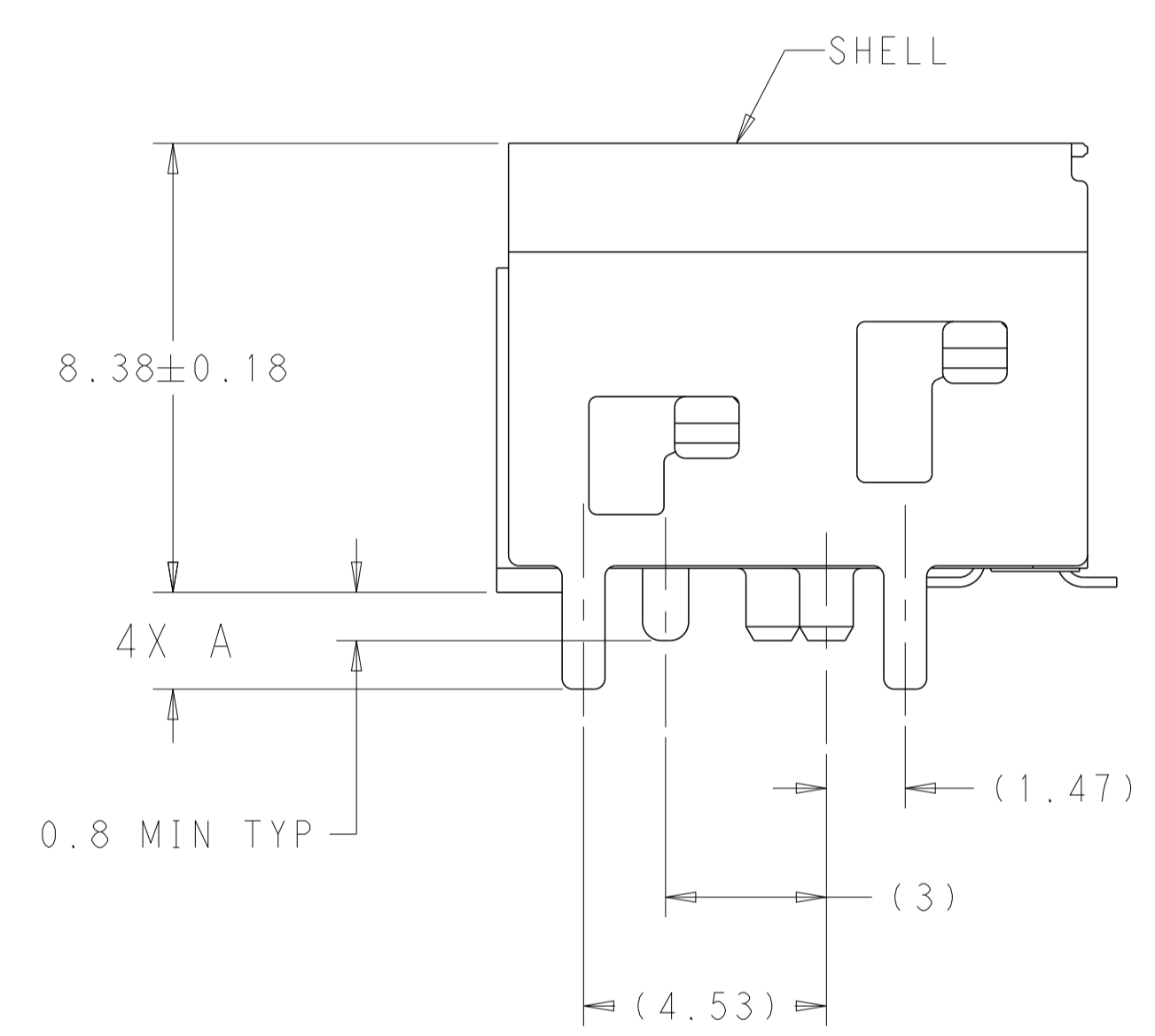
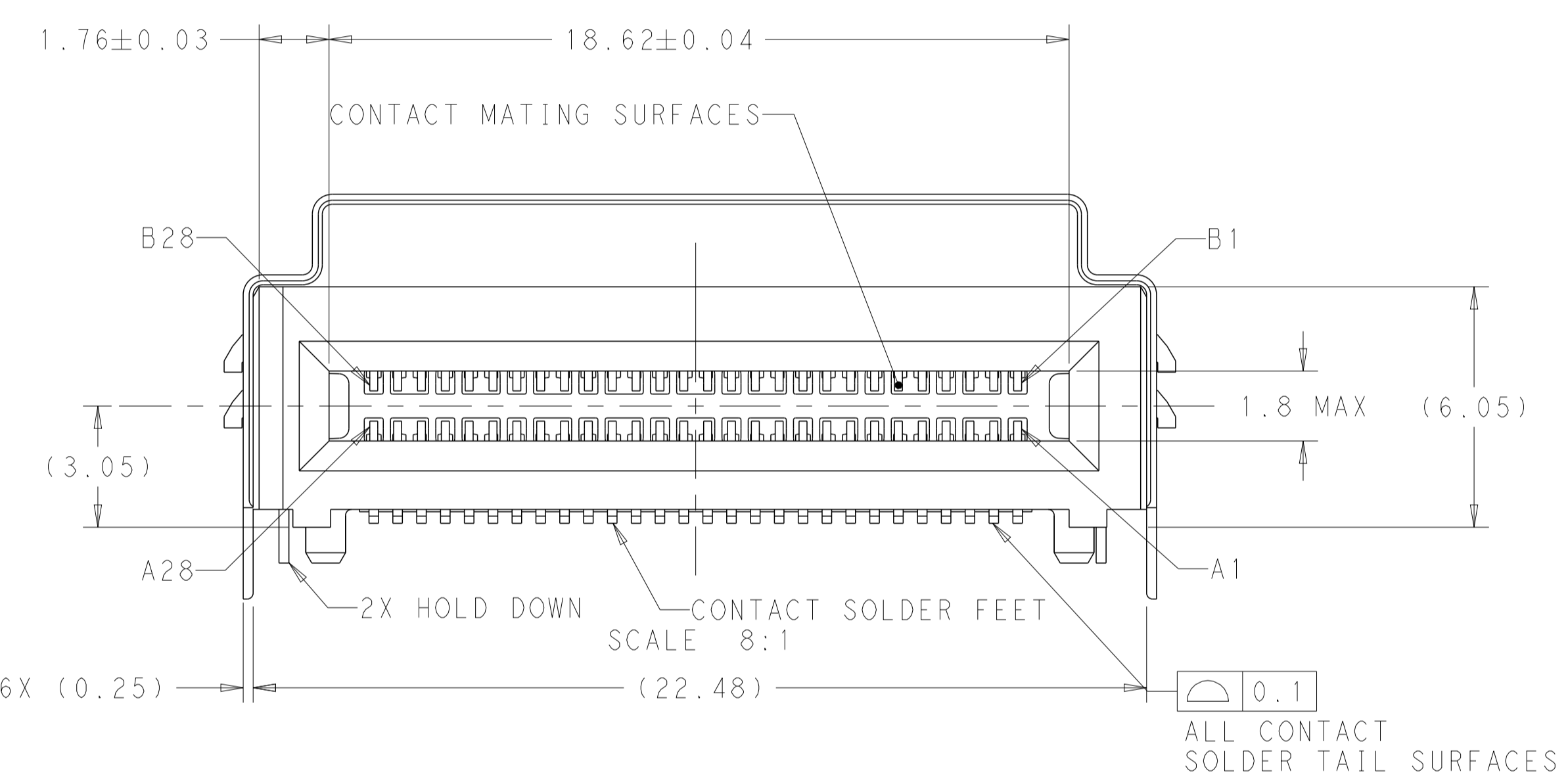
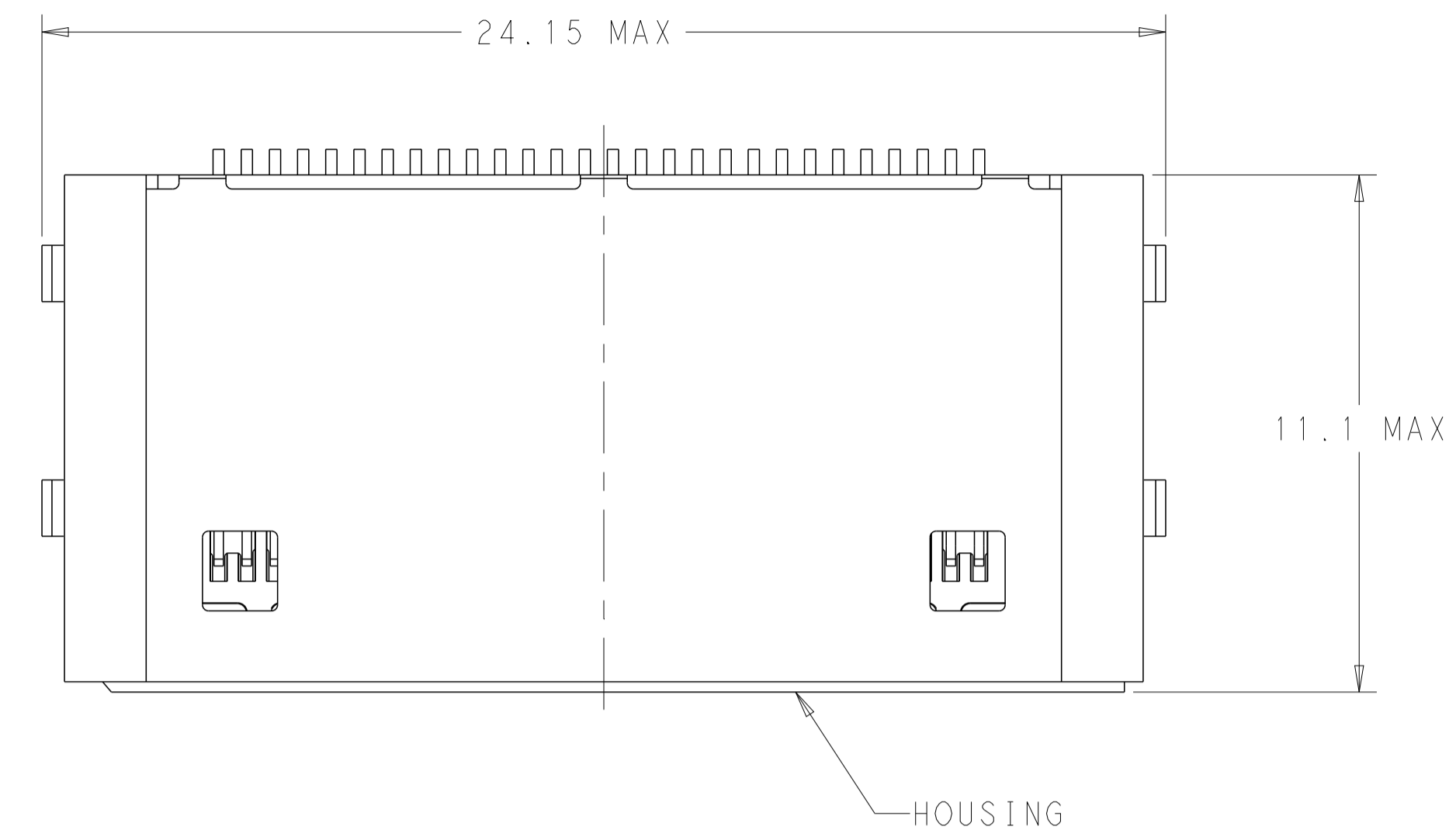

DETAIL D
SCALE 20:1

- △ HOUSING, ORGANIZER AND CONTACT OVERMOLDS - LCP, UL94V-0, BLACK. SHELL, CONTACTS AND HOLD DOWNS - COPPER ALLOY.
- △ CONTACTS - GOLD PLATE ON MATING SURFACES, TIN PLATE ON SOLDER FEET. HOLD DOWNS - TIN PLATE. SHELL - NICKEL PLATE, TIN PLATE ON HOLD DOWNS.
- △ DATUMS AND BASIC DIMENSIONS ESTABLISHED BY CUSTOMER.
- 4. MINIMUM HOST PCB THICKNESS: 1.5.
- △ SEE MSA SPECIFICATION FOR ADDITIONAL PADDLE CARD LAYOUTS COMPATIBLE WITH THIS RECEPTACLE AND FOR OPTIONAL SPLIT CONTACT PAD LAYOUTS FOR THE PADDLE CARD. SPECIFICATION PINOUT MAY ALSO DESIGNATE PAD SEQUENCE DIFFERENT FROM ILLUSTRATION.
- △ POSITIONS DESIGNATED AS "SIGNAL" ARE REQUIRED LOCATIONS FOR HIGH SPEED DIFFERENTIAL PAIR SIGNALING. THESE LOCATIONS MAY ALSO BE USED FOR SUPPORTING SIDEBAND SIGNALS OR OTHER UTILITY PURPOSES. POSITIONS DESIGNATED AS "GROUND" ARE REQUIRED WHEN SUPPORTING HIGH SPEED DIFFERENTIAL SIGNALS. THESE LOCATIONS MAY ALSO BE USED FOR SIDEBAND SIGNALS OR OTHER UTILITY PURPOSES.
- △ COMPONENT AND TRACES KEEP OUT AREA. EACH EDGE 0.15 MIN FROM EDGE OF HOLE.
- △ TAPE AND REEL PACKAGED FOR PICK AND PLACE SURFACE MOUNT PROCESSING, SEE FIGURE 1 AND FIGURE 2. POCKET TAPE: WIDTH = 44.

SEE SHEET 4
FOR PART TABLE

THIS DRAWING IS A CONTROLLED DOCUMENT.		OWN: B. MATTHEWS 29MAR2018	TE Connectivity
		CHK: D. HARMON 29MAR2018	
DIMENSIONS:		APVD: D. HARMON 29MAR2018	NAME: RECEPTACLE ASSEMBLY, RIGHT ANGLE, 56 POSITION, SLIVER 2.0
mm	TOLERANCES UNLESS OTHERWISE SPECIFIED:	PRODUCT SPEC	SIZE: CAGE CODE: DRAWING NO:
0 PLC ±	1 PLC ±	108-130021	A100779C=2332208
2 PLC ±	3 PLC ±	APPLICATION SPEC	RESTRICTED TO:
4 PLC ±	ANGLES ±	114-130015	SCALE: 10:1 SHEET 1 OF 5 REV: C1
MATERIAL	FINISH	WEIGHT	CUSTOMER DRAWING

REVISIONS				
P.	LTN.	DESCRIPTION	DATE	APVD.
-	-	SEE SHEET 1	-	-

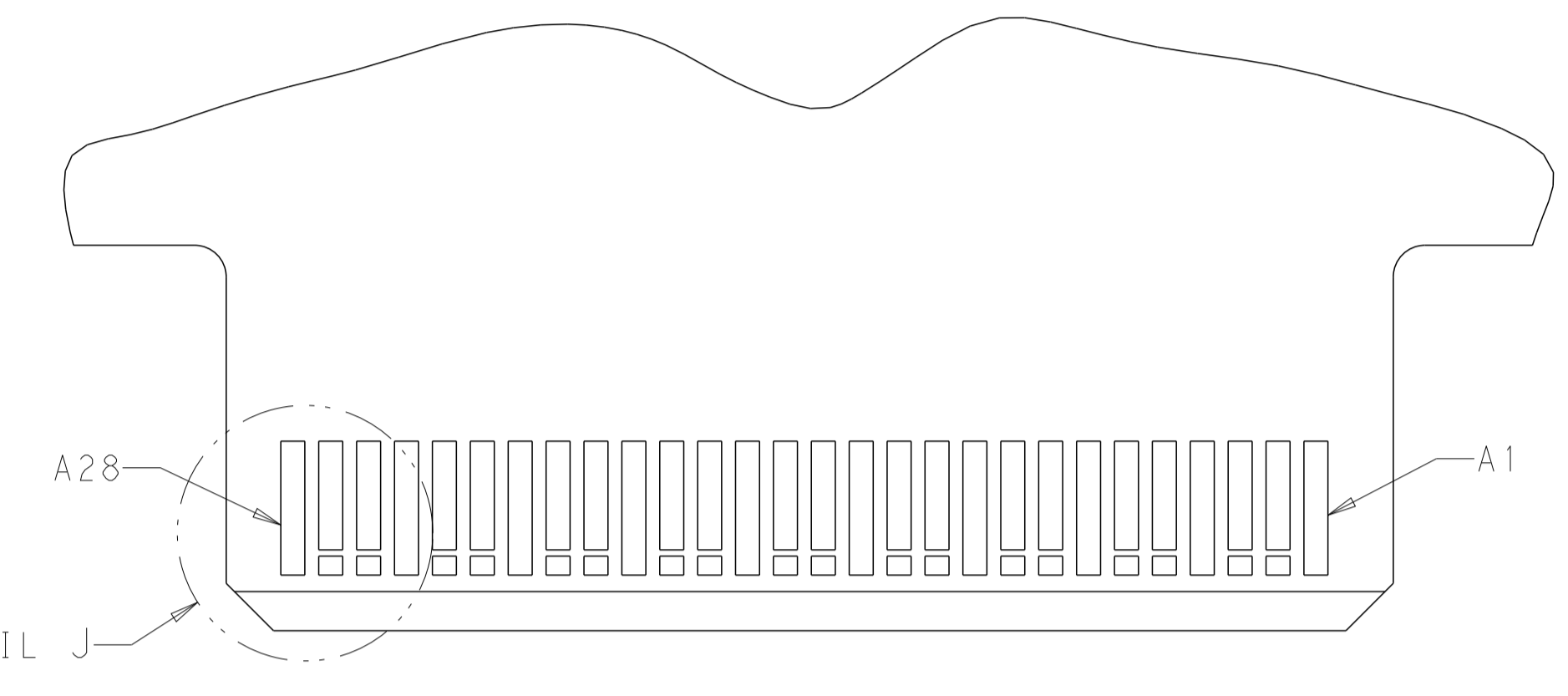
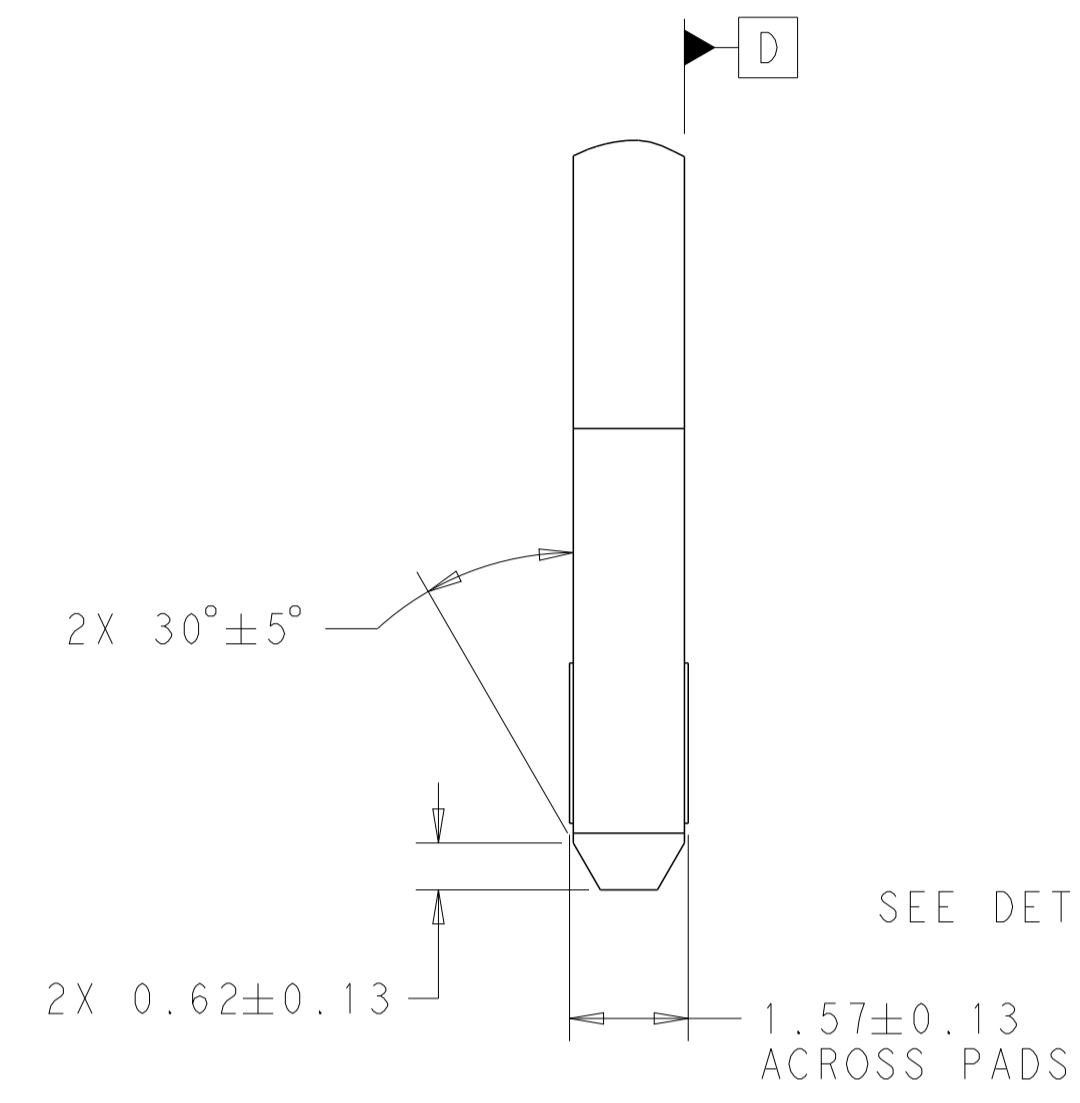
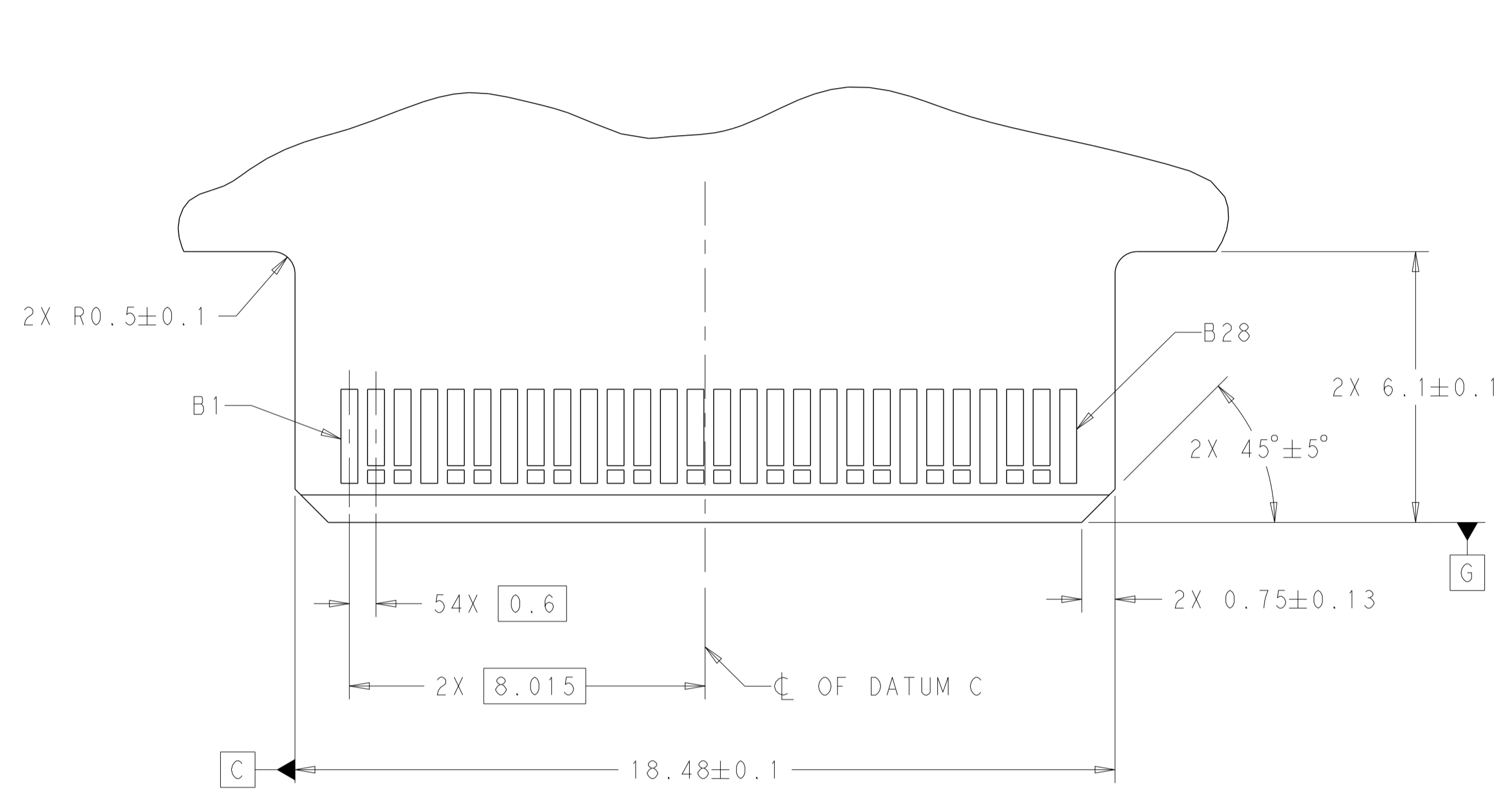

RECOMMENDED PCB OUTLINE DIMENSIONS:
 TOLERANCE VALUES ARE CRITICAL. PLEASE BE SURE TO DESIGNATE
 TOLERANCES TO PCB SUPPLIER TO ENSURE OPTIMIZED FUNCTIONALITY.

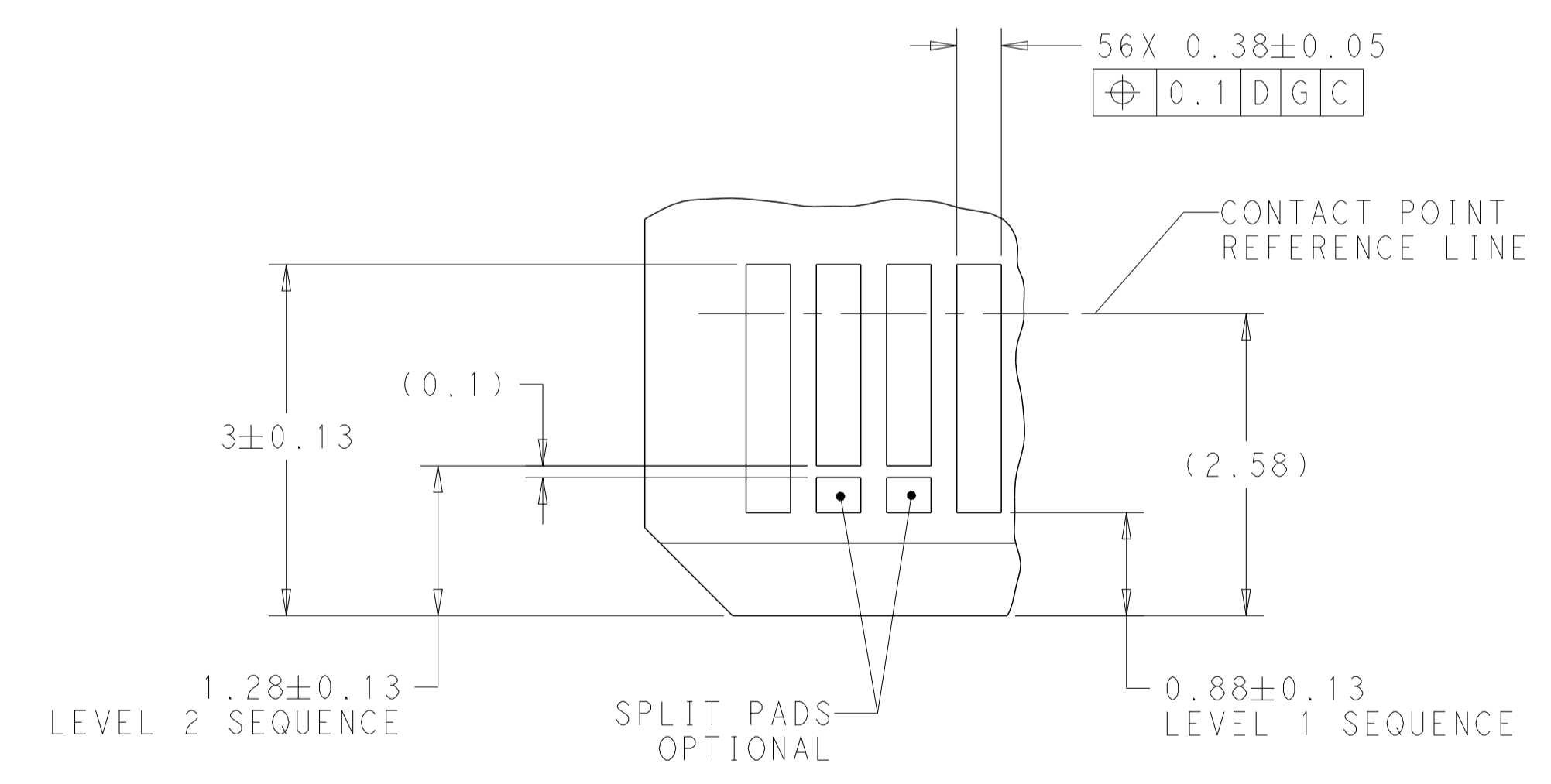

DETAIL J
 SCALE 20:1

THIS DRAWING IS A CONTROLLED DOCUMENT.		OWN: B. MATTHEWS 29MAR2018	TE Connectivity
DIMENSIONS: mm		CHK: D. HARMON 29MAR2018	
TOLERANCES UNLESS OTHERWISE SPECIFIED:		APVD: D. HARMON 29MAR2018	NAME: RECEPTACLE ASSEMBLY, RIGHT ANGLE, 56 POSITION, SLIVER 2.0
0 PLC ±	1 PLC ±	PRODUCT SPEC	SIZE: CAGE CODE DRAWING NO
2 PLC ±	3 PLC ±	108-130021	RESTRICTED TO
4 PLC ±	ANGLES ±	APPLICATION SPEC	A100779C=2332208
MATERIAL	FINISH	114-130015	SCALE 10:1 SHEET 3 OF 5 REV C1
CUSTOMER DRAWING		WEIGHT	

REVISIONS				
P.	LTN.	DESCRIPTION	DATE	APVD.
-	-	SEE SHEET 1	-	-

TABLE 1: CONNECTOR CONTACT IDENTIFICATION \triangle \triangle 6

CONTACT NUMBER	SIDE A	SIDE B
1	GROUND	GROUND
2	SIGNAL	SIGNAL
3	SIGNAL	SIGNAL
4	GROUND	GROUND
5	SIGNAL	SIGNAL
6	SIGNAL	SIGNAL
7	GROUND	GROUND
8	SIGNAL	SIGNAL
9	SIGNAL	SIGNAL
10	GROUND	GROUND
11	SIGNAL	SIGNAL
12	SIGNAL	SIGNAL
13	GROUND	GROUND
14	SIGNAL	SIGNAL
15	SIGNAL	SIGNAL
16	GROUND	GROUND
17	SIGNAL	SIGNAL
18	SIGNAL	SIGNAL
19	GROUND	GROUND
20	SIGNAL	SIGNAL
21	SIGNAL	SIGNAL
22	GROUND	GROUND
23	SIGNAL	SIGNAL
24	SIGNAL	SIGNAL
25	GROUND	GROUND
26	SIGNAL	SIGNAL
27	SIGNAL	SIGNAL
28	GROUND	GROUND

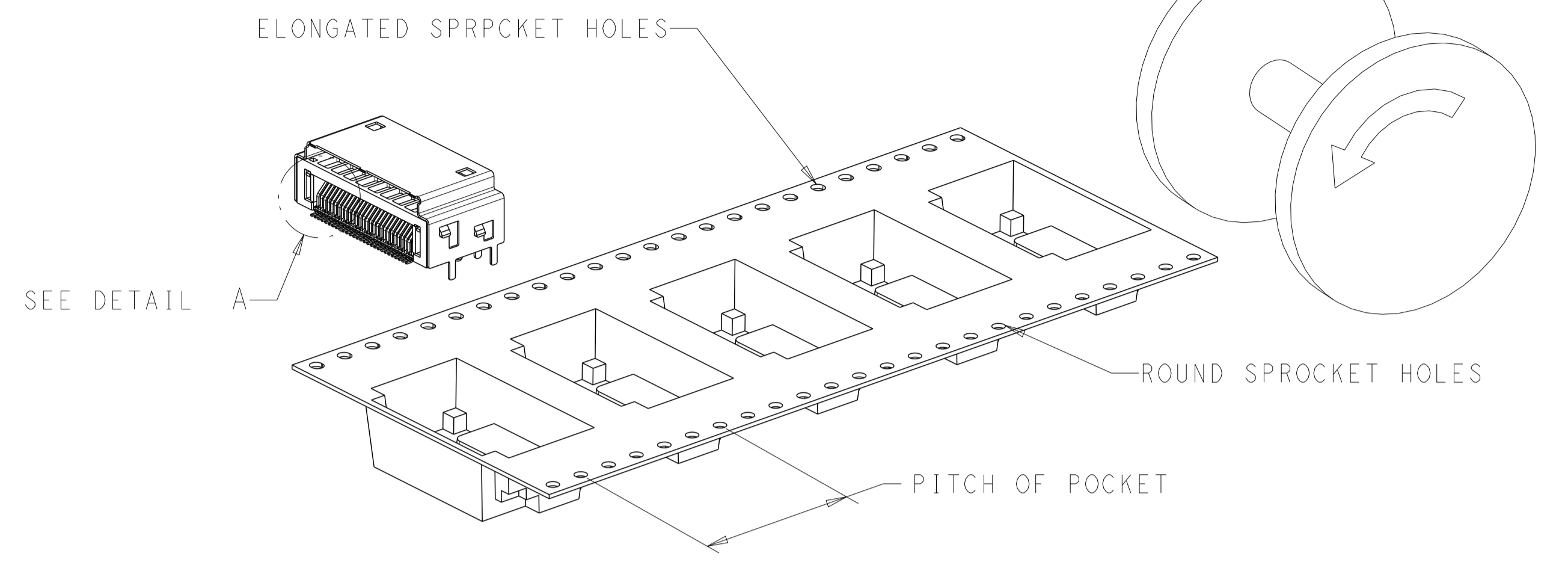
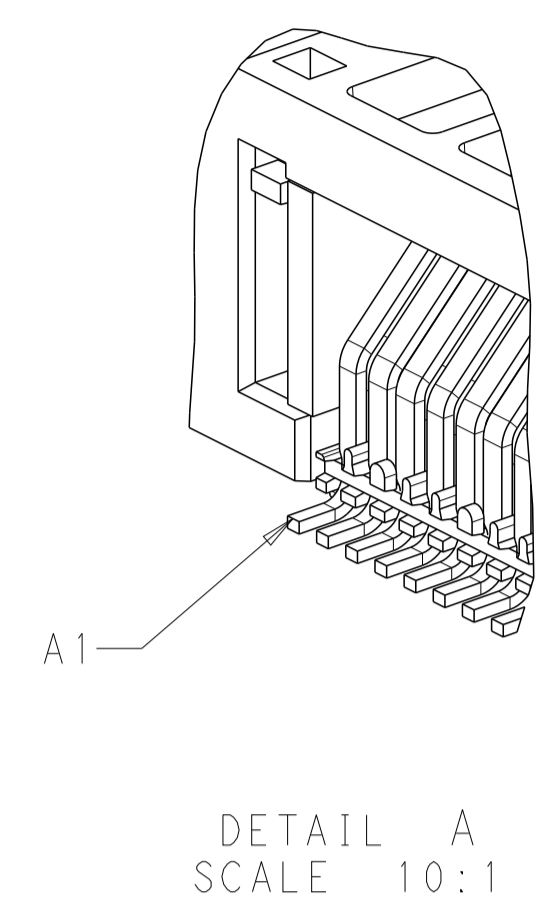

FIGURE 1 \triangle
 DIRECTION OFF TOP OF REEL
 FOR USER UNREELING FOR 2332208-1,
 2332208-2 AND 2332208-4 TO 2332208-6
 SCALE 2:1

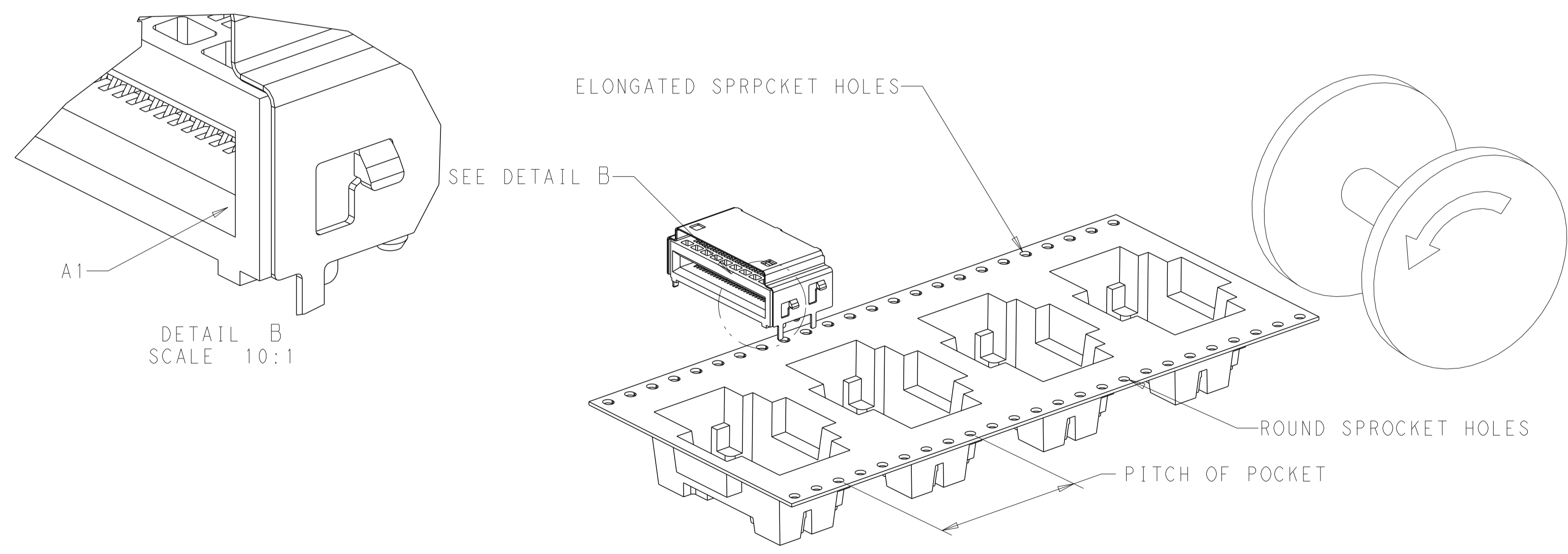

FIGURE 2 \triangle
 DIRECTION OFF TOP OF REEL
 FOR USER UNREELING
 FOR 1-2332208-1 TO 1-2332208-6
 SCALE 2:1

	1.8 +0.2/-0.1	0.76 μ m Au	20	350	200	1-2332208-0
OBSOLETE	3 \pm 0.1	0.76 μ m Au	24	300	200	1-2332208-9
OBSOLETE		0.38 μ m Au			100	1-2332208-8
OBSOLETE	1.2 \pm 0.2	FLASH Au/PdNi	24	300	50	1-2332208-7
		0.76 μ m Au			200	1-2332208-6
	1.8 +0.2/-0.1	0.38 μ m Au	24	300	100	1-2332208-5
		FLASH Au/PdNi			50	1-2332208-4
	1.8 +0.2/-0.1	0.76 μ m Au	24	300	200	1-2332208-3
		0.38 μ m Au			100	1-2332208-2
	3 \pm 0.1	FLASH Au/PdNi	20	350	50	1-2332208-1
OBSOLETE		0.76 μ m Au			200	2332208-9
OBSOLETE	1.2 \pm 0.2	0.38 μ m Au	20	350	100	2332208-8
OBSOLETE		FLASH Au/PdNi			50	2332208-7
	1.2 \pm 0.2	0.76 μ m Au	20	350	200	2332208-6
		0.38 μ m Au			100	2332208-5
	1.8 +0.2/-0.1	FLASH Au/PdNi	20	350	50	2332208-4
		0.76 μ m Au			200	2332208-3
	1.8 +0.2/-0.1	0.38 μ m Au	20	350	100	2332208-2
		FLASH Au/PdNi			50	2332208-1
	A	PLATING	POCKET TAPE PITCH	REEL QUANTITY	MATING CYCLES	PART NUMBER

THIS DRAWING IS A CONTROLLED DOCUMENT.

OWN: B. MATTHEWS 29MAR2018
 CHK: D. HARMON 29MAR2018
 APVD: D. HARMON 29MAR2018

DIMENSIONS: mm
 TOLERANCES UNLESS OTHERWISE SPECIFIED:
 0 PLC \pm
 1 PLC \pm
 2 PLC \pm
 3 PLC \pm
 4 PLC \pm
 ANGLES \pm
 FINISH

MATERIAL

WEIGHT: 114-130015
 CUSTOMER DRAWING

NAME: RECEPTACLE ASSEMBLY, RIGHT ANGLE, 56 POSITION, SLIVER 2.0
 PRODUCT SPEC: 108-130021
 APPLICATION SPEC: -

SIZE: A1
 CAGE CODE: 00779
 DRAWING NO: C=2332208

RESTRICTED TO: -

SCALE: 10:1
 SHEET: 4 OF 5
 REV: C1

TE Connectivity

REVISIONS				
P.	LTN	DESCRIPTION	DATE	APVD
-	-	SEE SHEET 1	-	-

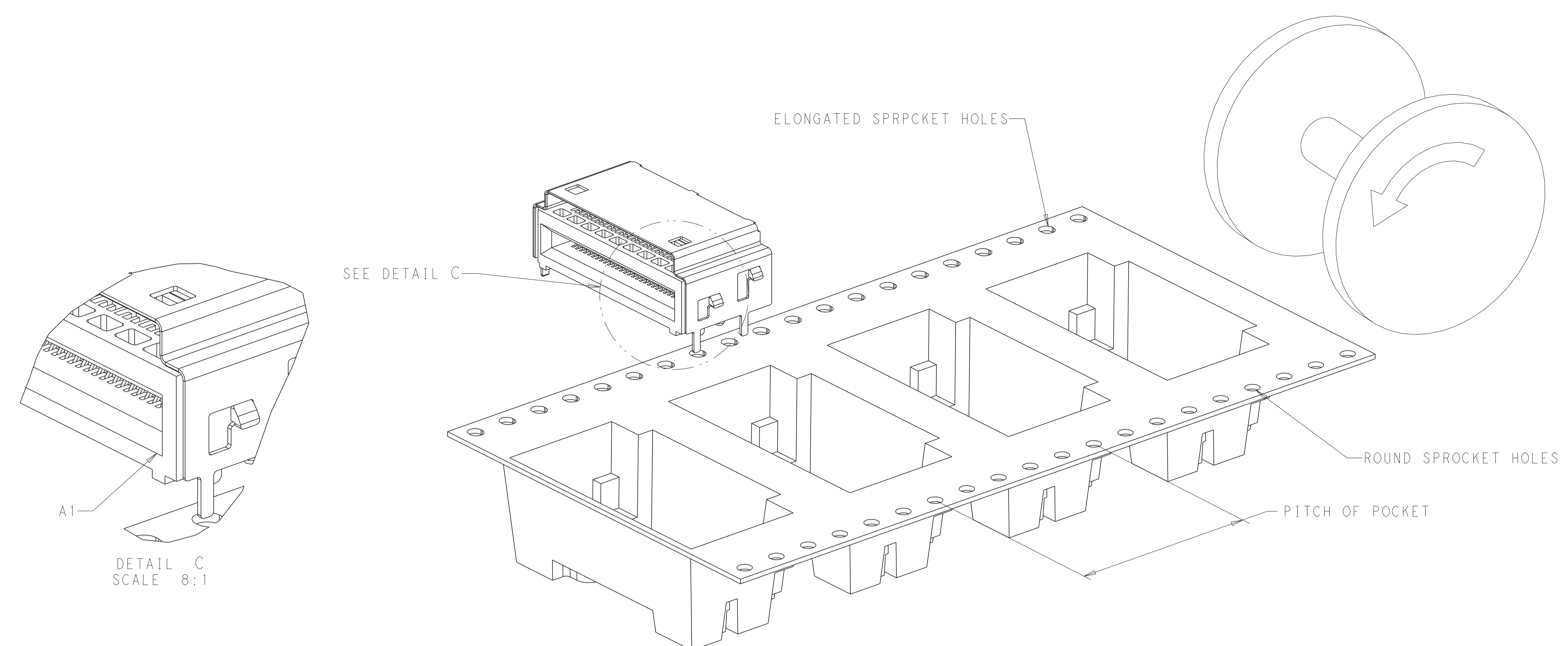

A1
 DETAIL C
 SCALE 8:1

FIGURE 3 
 DIRECTION OFF TOP OF REEL
 FOR USER UNREELING
 FOR 2332208-3 AND 1-2332208-0
 SCALE 4:1

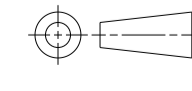
THIS DRAWING IS A CONTROLLED DOCUMENT.		OWN: B. MATTHEWS 29MAR2018	 TE Connectivity
		CHK: D. HARMON 29MAR2018	
DIMENSIONS:		APVD: D. HARMON 29MAR2018	NAME: RECEPTACLE ASSEMBLY, RIGHT ANGLE, 56 POSITION, SLIVER 2.0
TOLERANCES UNLESS OTHERWISE SPECIFIED:		PRODUCT SPEC: 108-130021	
mm	0 PLC ±	APPLICATION SPEC: 114-130015	SIZE: A1
	1 PLC ±	WEIGHT: -	CAGE CODE: 2332208
	2 PLC ±	CUSTOMER DRAWING	RESTRICTED TO: -
	3 PLC ±	SCALE: 10:1	SHEET: 5 OF 5
	4 PLC ±		REV: C1
	ANGLES ±		
	FINISH ±		