



GS1011M

LOW-POWER WIRELESS SYSTEM-ON-CHIP WI-FI MODULE

DATA SHEET

Reference: GS1011M-DS

Version: SP-1.6

Date: 1-Mar-13

Information in this document is provided in connection with GainSpan products. No license, express or implied, to any intellectual property rights is granted by this document. GainSpan assumes no liability whatsoever, and disclaims any express or implied warranty, relating to sale and/or use of GainSpan products including liability or warranties relating to fitness for a particular purpose, merchantability, or infringement of any patent, copyright or other intellectual property right. GainSpan products are not authorized for use as critical components in medical, lifesaving, or life-sustaining applications

GainSpan may make changes to specifications and product descriptions at any time, without notice.

*Other names and brands may be claimed as the property of others.

Copyright © 2009-2011 by GainSpan Corporation. (www.gainspan.com)
All Rights Reserved.

GainSpan Corporation

+1 (408) 673-2900

Version	Date	Remarks
1.0	20-May-2011	Updated description of ext_resetn and UART RTS/CTS signals Added power consumption information for deep sleep Updated package information to match module package Updated min Vbat spec and Receiver sensitivity numbers Updated latency numbers for GS1011ME module in 2.4.1
1.1	14-June-2011	Updated package drawing to reflect measurements from datum in bottom right corner for the bottom view Updated section 3.1.1 to make signal state column match description column
1.2	20-June-2011	Updated bottom view drawing for GS1011MI in Fig 5-2
1.4	27-April-2012	Updated Sleep States Description with more details Updated Layout guidelines with additional details Updated power consumption table with max current consumption values for GS1011Mxx Updated RF Parameter table (MI typical output to 9dBm)
1.5	15-Oct-2012	Updated ordering info for module rev 1.3 Added note related to module firmware in the ordering section
1.6	1-Mar-13	Updated section 5.2.1 reflow profile info and package info

Table of Contents

1	Overview	7
1.1	Document Overview.....	7
1.2	Product Overview.....	7
2	Architecture	9
2.1	G1011Mxx Block Diagram.....	9
2.2	Block Diagram Description.....	10
2.2.1	Overview	10
2.2.2	Wireless LAN and System Control Subsystem.....	10
2.2.2.1	Onboard antenna / RF port / Radio	11
2.2.3	Network Services Subsystem	11
2.2.3.1	APP CPU	11
2.2.4	Memory Subsystem.....	11
2.2.4.1	Overview.....	11
2.2.5	Clock Circuitries	11
2.2.5.1	Real Time Clock (RTC) Overview	11
2.2.5.2	Real Time Counter.....	13
2.2.5.3	RTC Outputs	13
2.2.5.3.1	DC_DC_CNTL.....	14
2.2.5.3.2	RTC_OUT1.....	14
2.2.5.4	RTC Alarm Inputs 1 and 2.....	14
2.3	Peripherals.....	14
2.3.1	SPI.....	14
2.3.2	I ² C	15
2.3.3	UART.....	16
2.3.4	JTAG.....	16
2.3.5	GPIO & LED Driver / GPIO.....	17
2.3.6	ADC	17
2.4	System States.....	18
2.5	Power Supply	21
2.5.1	Power Supply Connection Summary	24
3	Pin-out and Signal Description.....	26
3.1	GS1011Mxx Device Pin-out Diagram (Module top view)	26
3.1.1	GS1011Mxx Module Pins Description	27
4	Electrical Characteristics	31
4.1	Absolute Maximum Ratings.....	31
4.2	Operating Conditions	31
4.3	Internal 1.8V regulator	32
4.4	I/O DC Specifications	32
4.4.1	Digital Input Specifications.....	32
4.4.2	Digital Output Specification	32
4.4.3	I/O Digital Specifications (Tri-State).....	33
4.4.4	RTC Input Specifications (with Schmitt Trigger).....	33
4.4.5	RTC Output Specifications	34
4.5	Power Consumption (Estimated).....	34
4.6	Radio Parameters.....	34
4.7	ADC Parameters.....	35
4.8	SPI Interface Timing	36

4.8.1	Motorola SPI, clock polarity SPO = 0, clock phase SPH = 0	36
4.8.2	Motorola SPI, clock polarity SPO = 0, clock phase SPH = 1	38
4.8.3	Motorola SPI, clock polarity SPO = 1, clock phase SPH = 0	40
4.8.4	Motorola SPI, clock polarity SPO = 1, clock phase SPH = 1	42
5	Package and Layout Guidelines	44
5.1	GS1011Mxx Recommended PCB Footprint and Dimensions	44
5.2	GS1011MxP Layout Guidelines.....	46
5.2.1	Surface Mount Assembly	48
6	Ordering Information.....	50
7	Regulatory Notes	51
8	Limitations.....	53
9	References	54

Figures

Figure 2-1: GS1011MIx Block Diagram.....	9
Figure 2-2: GS1011MEx Block Diagram.....	9
Figure 2-4: GS1011Mxx System States	18
Figure 2-5 : GS1011Mxx Always ON Power Supply Connection.....	21
Figure 2-6: GS1011MIx Battery Powered with 3.3V IO and Standby Support.....	22
Figure 2-7 : GS1011ME Battery Powered with 3.3V IO and Standby Support.....	23
Figure 2-8 : GS1011MI Battery Powered with 1.8V only and Standby Support.....	24
Figure 2-9: Single board design using either GS1011MI or GS1011ME modules with Standby Support.....	25
Figure 3-1: GS1011Mxx Device Pin-out Diagram (Module top view).....	26
Figure 3-2: Module pin connection diagram	30
Figure 4-1: timing diagram, Master mode, SPO=SPH=0.....	36
Figure 4-2: timing diagram, Slave mode, SPO=SPH=0.....	37
Figure 4-3: timing diagram, Master, SPO=0, SPH=1.....	38
Figure 4-4: timing diagram, Slave, SPO=0, SPH=1.....	39
Figure 4-5: timing diagram, Master mode, SPO=1, SPH=0.....	40
Figure 4-6: timing diagram, Slave mode, SPO=1, SPH=0.....	41
Figure 4-7: timing diagram, Master mode, SPO=SPH=1.....	42
Figure 4-8: timing diagram, Slave mode, SPO=SPH=1.....	43
Figure 5-1: GS1011MIx Module Recommended PCB Footprint (in inches).....	44
Figure 5-2: GS1011MIx Module Dimensions (in inches).....	45
Figure 5-3: GS1011MEx Module Recommended PCB Footprint (in inches)	45
Figure 5-4: GS1011MEx Module Dimensions (in inches).....	46
Figure 5-5: GS1011MxP module onboard antenna keep-out layout guidelines (dimensions are in inches)	46
Figure 5-6 Recommended keep out area to accommodate both GS1011MIP and GS1011MEP.....	47
Figure 5-7 Recommended clearance above and below the GS1011MxP trace antenna	48
Figure 5-8: Reflow temperature profile.....	48

Tables

Table 3-1: Signal Description.....	29
Table 4-1: Absolute Maximum Ratings	31
Table 4-2: Operating Conditions	31
Table 4-3: Internal 1.8V Regulator	32
Table 4-4: Digital Input Parameters	32
Table 4-5: Digital Output Parameters.....	32
Table 4-6: I/O Digital Parameters	33
Table 4-7: RTC Input Parameters.....	33
Table 4-8: RTC Output Parameters	34
Table 4-9: Power Consumption in Different States.....	34
Table 4-10: Radio Parameters	35
Table 4-11: ADC Parameters	35
Table 4-12: timing parameters, Master mode, SPO=SPH=0.	36
Table 4-13: timing parameters, Slave mode, SPO=SPH=0.....	37
Table 4-14: timing parameters, Master mode; SPO=0, SPH=1.	38
Table 4-15: timing parameters, Slave mode, SPO=0, SPH=1.....	39
Table 4-16: timing parameters, Master mode, SPO=1, SPH=0.....	40
Table 4-17: timing parameters, Slave mode, SPO=1, SPH=0.....	41
Table 4-18: timing parameters, Master mode, SPO=SPH=1.	42
Table 4-19: timing parameters, Master mode, SPO=SPH=1.	43
Table 5-1: Recommended reflow parameters.....	48

1 Overview

1.1 Document Overview

THIS DOCUMENT describes the GS1011Mxx Low Power module hardware specification. The GS1011 based modules provide cost effective, low power, and flexible platform to add Wi-Fi® connectivity for embedded devices for a variety of applications, such as wireless sensors and thermostats. It combines ARM7-based processors with an RF transceiver, 802.11 MAC, security, & PHY functions, FLASH and SRAM, onboard and off module certified antenna options, and various RF front end options for end customer range needs in order to provide a WiFi and regulatory certified IEEE 802.11 radio with concurrent network processing services for variety of applications, while leverage existing 802.11 [1] wireless network infrastructures.

1.2 Product Overview

- ▶ Family of modules with different antenna and output power options:
 - GS1011MIx 1.280 inches by 0.900 inches by 0.143 inches (Length * Width * Height) 48-pin Dual Flat pack PCB Surface Mount Package.
 - GS1011MEx 1.450 inches by 0.900 inches by 0.143 inches (Length * Width * Height) 48-pin Dual Flat pack PCB Surface Mount Package.
 - GS1011MIP, GS1011MIE, GS1011MEP, and GS1011MEE are all pin to pin compatible (see section 6 Ordering Information), and the user has to account only for power consumption, module outline, and PCB antenna keep out (if used) to accommodate “one size fits all” for various end applications.
 - Simple API for embedded markets covering large areas of applications
- ▶ Compliant with IEEE 802.11 and regulatory domains:
 - Fully compatible with IEEE 802.11b/g/n.
 - DSSS modulation for data rates of 1 Mb/s and 2 Mb/s; CCK modulation rates of 5.5 and 11 Mb/s.
 - Supports short preamble and short slot times.
 - WiFi Certified Solution
 - Supports 802.11i security
 - WPA™ - Enterprise, Personal
 - WPA2™ - Enterprise, Personal
 - Vendor EAP Type(s)
 - EAP-TTLS/MSCHAPv2, PEAPv0/EAP-MSCHAPv2, PEAPv1/EAP-GTC, EAP-FAST, EAP-TLS
 - Hardware High-throughput AES and RC4 encryption/decryption engines for WEP, WPA/WPA2 (AES and TKIP).
 - RoHS and CE compliant
 - FCC/IC/ ETSI Certified

	GS1011MIP	GS1011MIE	GS1011MEP	GS1011MEE
FCC ID	YOPGS1011MIP	YOPGS1011MIE	YOPGS1011MEP	YOPGS1011MEE
IC ID	9154A-GS1011MIP	9154A-GS1011MIE	9154A-GS1011MEP	9154A-GS1011MEE

- Fully compliant with EU & meets the R&TTE Directive for Radio Spectrum
- Japan Radio Type Approval (i.e. TELEC) pre-scan compliant
- ▶ Dual ARM7 Processor Platform:
 - 1st ARM7 processor (WLAN CPU) for WLAN software
 - 2nd ARM7 (APP CPU) for networking software
 - Based on Advanced Microprocessor Bus Architecture (AMBA) system:
 - AMBA High-Speed Bus (AHB).
 - AMBA Peripheral Bus (APB).
 - On-chip WLAN boot code located in dedicated boot ROM.
- ▶ Interfaces:
 - PCB or external antenna options, electronically selected.
 - Two general-purpose SPI interfaces (each configurable as master or slave) for external sensors, memory, or external CPU interface; one interface may be configured as a high-speed Slave-only.
 - Two multi-purpose UART interfaces.
 - Up to 23 configure able general purpose I/O.
 - Single 3.3V supply option
 - I/O supply voltage 1.8 ~ 3.3V option
 - One PWM output
 - I²C master/slave interface.
 - Two 10-bit ADC channels, aggregate sample rate 32 kS/s.
 - Two alarm inputs to asynchronously awaken the chip.
 - Support of up to two control outputs for power supply and sensors.
- ▶ Embedded RTC (Real Time Clock) can run directly from battery.
- ▶ Power supply monitoring capability.
- ▶ Low-power mode operations
 - ▶ Standby, Sleep, and Deep Sleep

2 Architecture

2.1 G1011Mxx Block Diagram

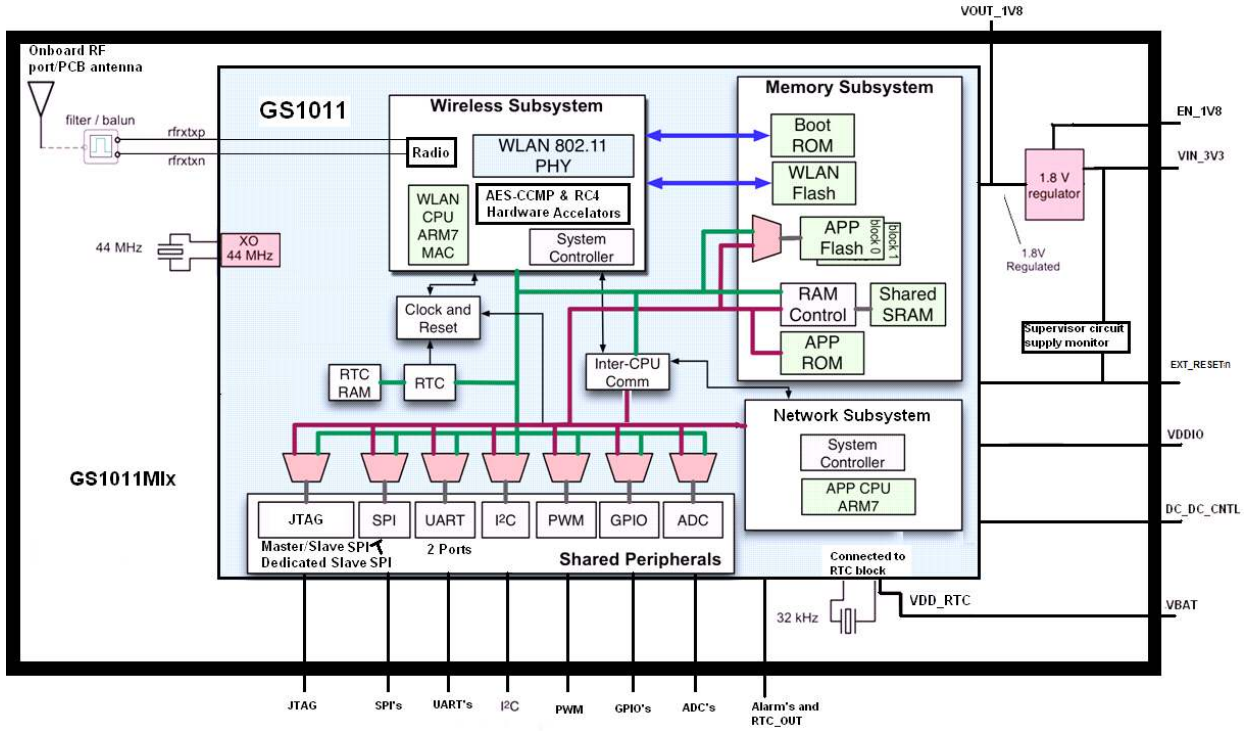

Figure 2-1: GS1011M1x Block Diagram

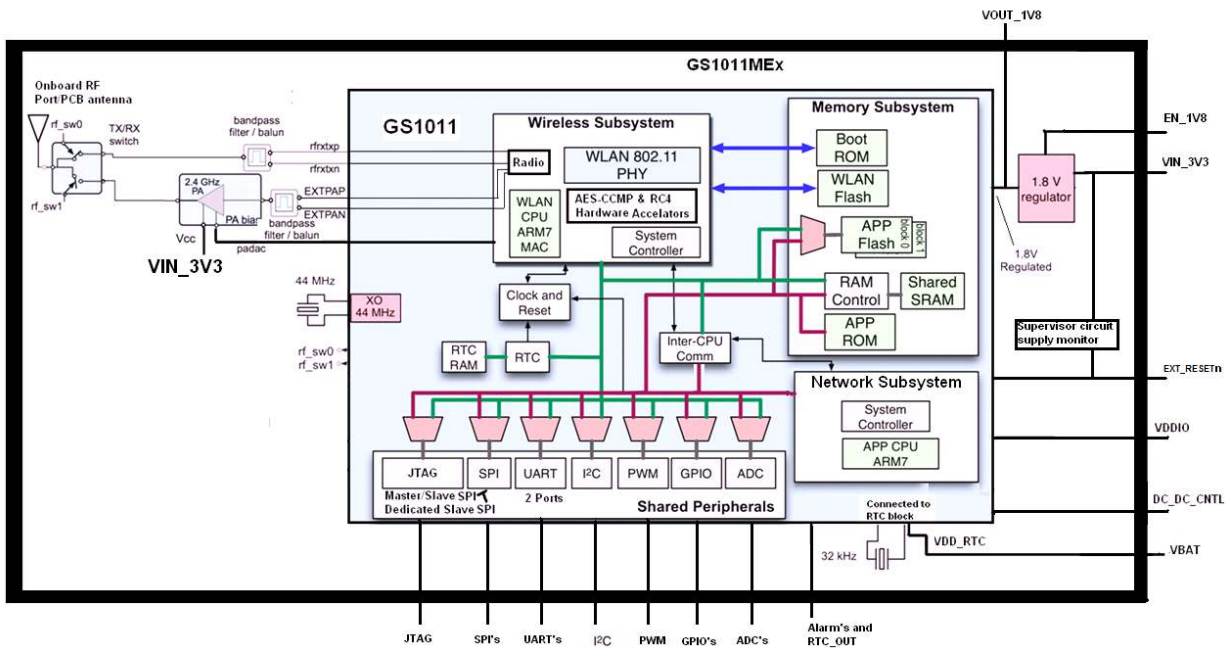

Figure 2-2: GS1011MEx Block Diagram

2.2 Block Diagram Description

2.2.1 Overview

GS1011Mxx module is a highly integrated ultra low power Wi-Fi system-on-chip (SOC) that contains the following:

- The module includes GS1011 SoC, which contains media access controller (MAC), baseband processor, security, on-chip flash memory and SRAM, and an applications processor in a single package.
- The module contains two ARM7-based processors, one dedicated to Networking Subsystems, and the other dedicated to Wireless Subsystems.
- The module carries an 802.11 radio with onboard 32 KHz & 44 MHz crystal circuitries, RF, and certified PCB antenna or external antenna options.
 - The low power module option has a capability of +9dBm output power at the antenna (see Figure 2-1).
 - The extended range module option has a capability of +18dBm output power at the antenna connector (see Figure 2-2).
- Variety of interfaces are available such as two UART blocks using only two data lines per port with optional hardware flow controls, two SPI block (one dedicated as a serial slave with configurable hardware interrupt to the HOST), I²C with Master or slave operation, JTAG port, low-power 10-bit ADC capable of running at up to 32 Ksamples/Sec., GPIO's, and LED Drivers/GPIO with 20mA capabilities.
- GS1011Mxx contains single power supply (VIN_3V3) with optional module controlled external regulator enable control pin (DC_DC_CNTL), a separate I/O supply (VDDIO) that can be tied to the HOST supply rail without the use of external voltage translators, Real Time Clock (RTC) with battery supply monitor option (VBAT), and two external alarm inputs enable wake-up of the system on external events & outputs (ALARM and RTC_OUT) to enable periodic wake-up of the remainder of the system.
 - The Module carries onboard single supply monitor for under voltage supply and onboard 1.8V regulator with enable/disable capabilities for power critical applications.

2.2.2 Wireless LAN and System Control Subsystem

The Wireless subsystem provides the WLAN PHY, MAC and baseband functionality. It contains the WLAN CPU, a 32-bit ARM7 TDMI-S core running at up to 44 MHz. It includes an IEEE 802.11b/g - compatible RF transceiver, which supports Direct Sequence Spread Spectrum (DSSS) 1 Mb/s and 2 Mb/s data rates, and Complementary Code Keyed (CCK) 5.5 Mb/s and 11 Mb/s data rates. The WLAN subsystem includes an integrated power amplifier, and provides management capabilities for an optional external power amplifier. In addition, it contains hardware support for AES-CCMP encryption (for WPA2) and RC4 encryption (for WEP & WPA/WPA2 TKIP) encryption/decryption.

The WLAN subsystem contains the control logic and state machines required to drive the low power DSSS modem, and perform pre-processing (in transmit mode) or post-processing (in receive mode) of the data stream. The WLAN subsystem manages DMA accesses, data encryption/decryption using the AES algorithm, and CRC computation.

2.2.2.1 Onboard antenna / RF port / Radio

The GS1011Mxx modules have fully integrated RF frequency synthesizer, reference clock, low power PA, and high power PA for extended range applications. Both TX and RX chain in the module incorporate internal power control loops. The GS1011Mxx modules also incorporate onboard printed antenna option plus a variety of regulatory certified antenna options for various application needs.

2.2.3 Network Services Subsystem

2.2.3.1 APP CPU

The Network services subsystem consists of an APP CPU which is based on an ARM7 TDMI-S core. It incorporates an AHB interface and a JTAG debug interface. The network RTOS, network stack, and customer application code can reside on this CPU. For more information, consult the GS1011 Peripheral and Register Description [2] and GS1011 SoC data sheet [3] for detailed descriptions.

2.2.4 Memory Subsystem

2.2.4.1 Overview

The GS1011 module contains several memory blocks:

- ▶ Boot ROM blocks.
 - ▶ The software contained in this ROM provides the capability to download new firmware via the SPI Slave or UART interfaces and to control the update of WLAN and APP Flash Memory.
- ▶ 384 KBytes of Embedded Flash to store program code.
 - ▶ Three embedded Flash blocks of 128K bytes each
 - ▶ WLAN Flash (contains the wireless LAN and system control subsystem software)
 - ▶ APP Flash 0 and 1 (contain the Network/Application Software)
- ▶ 128 Kbytes of RAM shared between the two integrated CPU's.
- ▶ 512 bytes of RTC memory ((retains data in all states, as long as the battery or other voltage supply is present)

For more information, consult the GS1011 Peripheral and Register Description [2] and GS1011 SoC data sheet [3] for detailed descriptions.

2.2.5 Clock Circuitries

The GS1011MXX architecture uses a low-power oscillator (i.e. 32 kHz) to provide a minimal subset of functions when the chip is in its low-power deep sleep mode, and a high-speed 44 MHz oscillator to provide clock signals for the processors, bus, and interfaces during active operation. Intermediate modes of operation, in which the 44 MHz oscillator is active but some modules are inactive, are obtained by gating the clock signal to different subsystems. The Clock & Reset Controller, within the device, is responsible for generation, selection and gating of the clocks used in the module to reduce power consumption in various power states.

2.2.5.1 Real Time Clock (RTC) Overview

To provide global time (and date) to the system, the GS1011MXX Chip is equipped with a low-power Real Time Clock (RTC).

RTC key features include:

- ▶ 32.768 kHz crystal support.
- ▶ Two external alarm inputs to wake up the device.
- ▶ Two programmable periodic outputs (one for a DC/DC regulator and one for a sensor).
- ▶ Embedded 128x32 non-volatile (battery-powered) RAM.
- ▶ Embedded Power On Reset.
- ▶ Real Time Counter (48 bits; 46 bits effective).

An overview of RTC block diagram is shown in Figure 2-3. The RTC contains a low-power oscillator that can use 32.768 kHz crystals. In normal operation the RTC is always powered up, even in the Power up state (see Figure 2-3).

Two programmable embedded alarm counters (wrap-around) are provided to enable periodic wake-up of the remainder of the system, and one independent external component (typically a sensor). Two external alarm inputs enable wake-up of the system on external events. The global times are recorded on each external event and if the system is in the Power-ON state (see Figure 2-8), an interrupt is provided. The RTC includes a Power-On Reset (POR) circuit, to eliminate the need for an external component. The RTC contains low-leakage non-volatile (battery-powered) RAM, to enable storage of data that needs to be preserved.

Total current consumption of the RTC in the worst case is typically less than 7 μ A without data storage, using the 32.768 kHz oscillator.

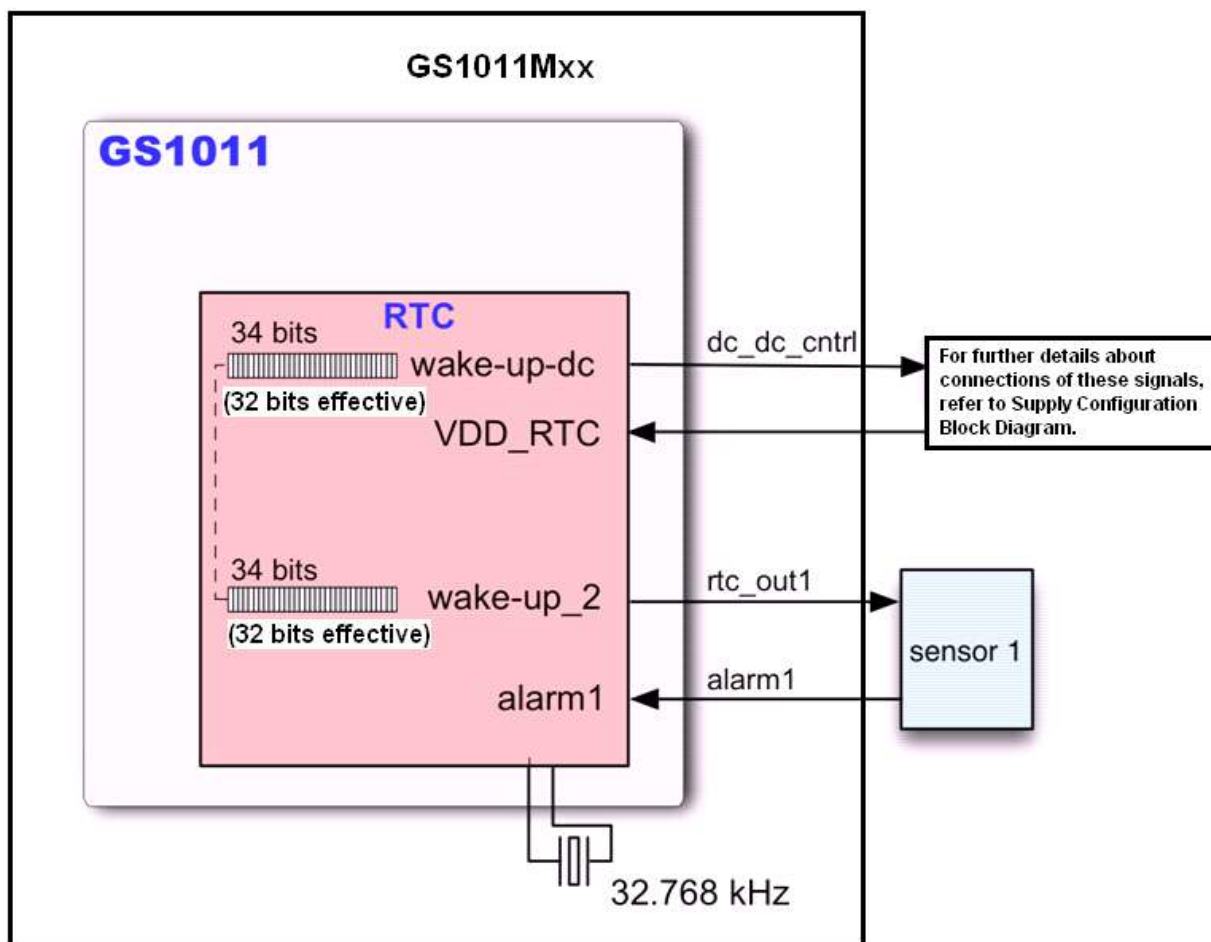

Figure 2-2: RTC Interface Diagram

Resolution of the wake-up timer is one clock cycle, and, with onboard 32KHz. CLK, each 32bit effective register can provide up to 1.5 days' worth of standby duration as the longest standby period. Polarity of the `rtc_out1` pin is programmable.

2.2.5.2 Real Time Counter

The Real Time Counter features:

- ▶ 48-bit length (with absolute duration dependent on the crystal frequency used).
- ▶ Low-power design.

This counter is automatically reset by power-on-reset.

This counter wraps around (returns to “all-0” once it has reached the highest possible “all-1” value).

2.2.5.3 RTC Outputs

There are two RTC outputs (`dc_dc_cntrl` and `rtc_out1`) that can be used to control external devices, such as sensors or voltage regulators. For more information, consult the GS1011 Peripheral and Register Description [2] and GS1011 SoC data sheet [3] for detailed descriptions.

2.2.5.3.1 DC_DC_CNTL

During RTC Power-on-Reset (e.g. when the battery is connected), the `dc_dc_cntl` pin is held low; it goes high to indicate completion of RTC power-on-reset. This pin can be used as an enable into an external device such as voltage regulator. For more information, consult the GS1011 Peripheral and Register Description [2] and GS1011 SoC data sheet [3] for detailed descriptions.

2.2.5.3.2 RTC_OUT1

The `rtc_out1` signal can be disabled or driven by the Wake-up Counter 2. This counter is 34 bits long, and operates in the same fashion as Wake-up Counter 1. The `rtc_out1` signal can be configured to output the low-power crystal oscillator clock (i.e. the 32 kHz clock) instead of a simple state transition. Wake-up Counter 2 is automatically reset at Power-on-Reset. For more information, consult the GS1011 Peripheral and Register Description [2] and GS1011 SoC data sheet [3] for detailed descriptions.

2.2.5.4 RTC Alarm Inputs 1 and 2

The RTC inputs `alarm1` and `alarm2` operate as follows:

- ▶ `dc_dc_cntl` is set to “1” (typically enabling the power supply to the rest of the GS1011) whenever either of these inputs changes state.
- ▶ The RTC counter value is stored each time either of these inputs changes state.

The inputs `alarm1` and `alarm2` have programmable polarity. Their task is to wake up the system (by setting `dc_dc_cntl` output pin to “1”) when an external event occurs. For more information, consult the GS1011 Peripheral and Register Description [2] and GS1011 SoC data sheet [3] for detailed descriptions.

2.3 Peripherals

Note: For register identification and additional details on the use of shared peripherals, refer to the GS1011 Peripheral and Register Description [3].

2.3.1 SPI

There are two general-purpose SPI interfaces (each configurable as master or slave) for external sensors, memory, or external CPU interface; The slave SPI (SSPI) may be configured as a fast-speed Slave-only. The fast SPI Slave is not shared, and is accessible only by the APP CPU. The fast SPI operates only in the Motorola-compatible SPI slave mode using 8-bit words and a 64-word FIFO buffer for both transmit and receive. The serial to Wi-Fi firmware which uses the SPI interfaces uses this fast SPI mode. The master SPI block provides dual synchronous serial communication interfaces. The Master SPI block can be used in one of two modes of operations: as a serial master or a serial slave. Each block provides synchronous serial communication with slave or master devices, using one of the following protocols:

- ▶ Motorola Serial Peripheral Interface (SPI).
- ▶ Texas Instruments Synchronous Serial Protocol (SSP).
- ▶ National Semiconductor Microwire Protocol.

Only Motorola Serial Peripheral Interface (SPI) timing is shown in this data sheet; however, National Semiconductor Microwire Protocol or Texas Instruments Synchronous Serial Protocol (SSP) modes are certainly supported. The SPI interface can also be used to access non-volatile external memory, such as an EEPROM block. The interface uses the SPI master mode to allow easy connection to industry-standard EEPROMs.

The shared SPI blocks provide the following general features:

- ▶ 32-bit AMBA APB interface to allow access to data, control, and status information by the host processor.
- ▶ Full-duplex serial-master or serial-slave operation.
- ▶ Two clock design:
 - APB bus clock for bus interface and registers.
 - Serial input clock for core logic.
- ▶ Support of external EEPROM or other non-volatile memory.
- ▶ Programmable choice of Motorola SPI, Texas Instruments Synchronous Serial Protocol or National Semiconductor Microwire.
- ▶ Programmable control of the serial bit rate of the data transfer in serial-master mode of operation.
- ▶ Programmable phase and polarity of the bit rate clock.
- ▶ Programmable transfer modes to perform transmit and receive, transmit only, receive only and EEPROM read transfers.
- ▶ Programmable data word size (8, 16, 24 & 32 bits) for each data transfer.
- ▶ Transmit and receive FIFO buffer depth 8 words (of the selected size).
- ▶ Configurable number of slave select outputs in serial-master mode of operation: 1 to 4 serial slave-select output signals can be generated.
- ▶ Combined interrupt line with independent masking of interrupts.
- ▶ Transmit FIFO overflow, transmit FIFO empty, transmit FIFO underflow, receive FIFO full, receive FIFO underflow, receive FIFO overflow, and receive FIFO timeout interrupts.
- ▶ Transmit FIFO empty and receive FIFO full interrupts provide programmable threshold values.

Both SPI blocks are configured to provide a FIFO depth of eight entries.

The SPI master interface can be used to access external sensor devices, and EEPROM containing system parameters, under software control while the SPI slave interface can be used to provide control of the GS1011M from an external CPU. The recommended clock speed when using external Host to communicate with the module is 1.4MHz

SPI chip select (MSPI_CS0 or MPSI_CS1) signals frame each data word. If the chip select is required to remain asserted for multiple data words, then a GPIO pin should be used for the chip select instead of the SPI chip select signals. For clock architecture and rates, please refer to section 7.1 Clock Architecture of GS1011 Peripheral and Register Description [2]. For other SPI Interface Timing, please refer to section 4.8

2.3.2 I²C

The I²C block provides a two-wire I²C serial interface. It provides the following features:

- ▶ 32-bit AMBA APB interface to allow access to data, control, and status Information by the host processor.
- ▶ Serial 2-wire I²C bus, compliant to the I²C Bus Specification Version 2.1.
- ▶ Supports only one transfer in Standard mode (100 Kb/s) and fast speed mode with a bit rate of up to 392 Kb/s.
- ▶ Supports Multi-Master System Architecture through I²C bus SCL line Synchronization and Arbitration.

- ▶ Transmitter and Receiver: The I²C block can act as the Transmitter or Receiver depending on the operation being performed.
- ▶ Master or slave I²C operation.
- ▶ 7- or 10-bit addressing.
- ▶ Ignores CBUS addresses (an older ancestor of I²C that used to share the I²C bus).
- ▶ Interrupt or polled mode operation.
- ▶ Combined interrupt line triggered by:
 - Tx FIFO not FULL.
 - Rx FIFO not EMPTY.
 - Rx FIFO FULL (can be used to transfer data by host interface in bursts).
 - Tx FIFO EMPTY (can be used to transfer data by host interface in bursts).
 - Rx FIFO OVER RUN.
 - Master mode to Slave Transfer Request.
 - Slave Transmit Request.
 - Break Interrupt (master mode): No Acknowledge received from slave for slave address or write data.
- ▶ Digital de-bounce logic for the received SDA and SCL lines.
- ▶ Hold Delay Insertion on SDA line.

2.3.3 UART

The GS1011MXX includes two UART blocks. Each UART block provides an asynchronous communication interface, using only two data lines: Rx data and Tx data. Hardware flow control using RTS/CTS signaling is provided as an option. The UART is a standard asynchronous serial interface, 16450/16550 compatible. It provides the following features:

- ▶ Operation in full-duplex mode.
- ▶ All standard bit rates up to 921.6 kbps are supported.
- ▶ RTS/CTS flow control handshake (standard 16550 approach).
- ▶ 5, 6, 7 and 8-bit character format.
- ▶ 1 or 2 stop bits (1.5 in case of a 5-bit character format).
- ▶ Parity bit: none, even, odd, mark, or space.
- ▶ 16-byte Rx and 16-byte Tx FIFOs.

The UART Serial port can be used to communicate with a PC or other devices, for debug or additional functionality.

2.3.4 JTAG

The JTAG ports facilitate debugging of the board and system designs. This block has the following features:

- ▶ Compliant to IEEE-1149.1 TAP ports.
- ▶ One JTAG boundary scans TAP port.
- ▶ One set of JTAG pins, that support the following mode of operation:

- APP ARM7TDMI-S Debug Mode.

A detailed example of JTAG debug access is described in GainSpan Application Note AN-011 [4].

2.3.5 GPIO & LED Driver / GPIO

The GPIO ports are referenced to VDDIO. Two GPIO pins called GPIO30_LED1 & GPIO31_LED2 have the capability to sink/source 20 mA typical (VDDIO=3.3V) to connect to devices such as switch contacts or LEDs. I2C_DATA/GPIO8 & I2C_CLK/GPIO9 have the capability to sink/source 12 mA typical (VDDIO=3.3V). Other GPIO's have the capability to sink/source 4 mA typical (VDDIO=3.3V). All inputs are capable of generating processor interrupts. They can be individually programmed to provide edge- or level-triggered interrupts. For details on configuring GPIO ports, refer to the GS1011 Peripheral and Register Description [2].

2.3.6 ADC

The ADC is a 10-bit, low-power, A-to-D converter capable of running at up to 32 ksps. The ADC contains an internal band-gap reference which provides a stable 1.2 V reference voltage. The ADC can be programmed to use the 1.8 V supply as the full-scale reference. The ADC uses an input clock with a maximum frequency of 1 MHz. A conversion requires 32 clock cycles.

When the internal band-gap reference is used, the reported integer *Value* at temperature T (°C) is related to the voltage V_{actual} at the input pin as:

$$V_{actual} = Value \left(\frac{1.2444 - 0.00014(25 - T)}{1023} \right)$$

When the 1.8V supply voltage is used as the reference, the corresponding relation is:

$$V_{actual} = Value \left(\frac{V_{DD,ADC} - 0.036}{1023} \right)$$

To reduce power consumption the ADC can be disabled automatically between periodic measurements and after single measurements.

For more information, consult the GS1011 Peripheral and Register Description [2] and GS1011 SoC data sheet [3] for detailed descriptions.

2.4 System States

Figure 2-8 shows the power management/clock states of the GS1011Mxx system.

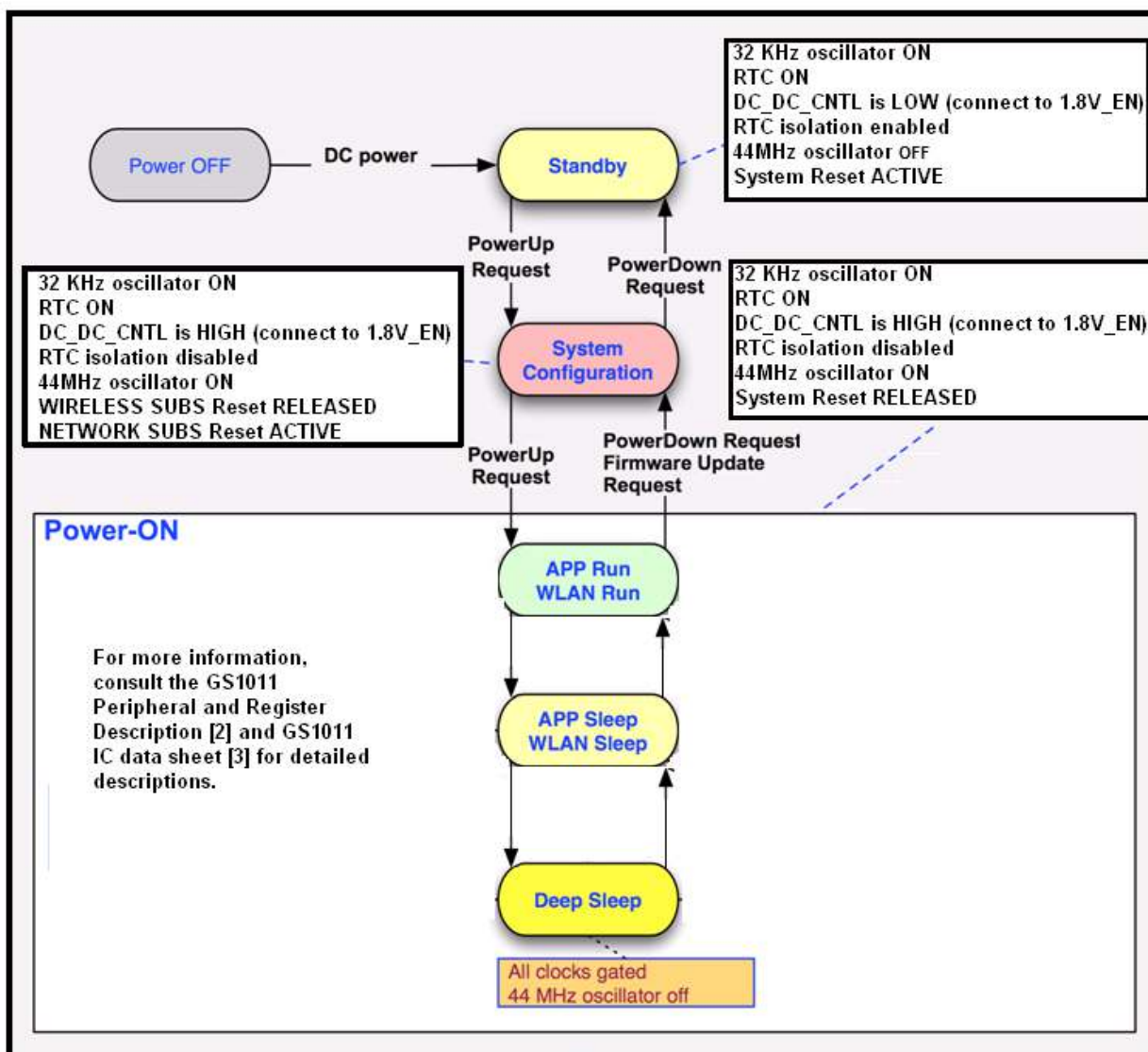

Figure 2-3: GS1011Mxx System States

The system states of the GS1011MXX system are as follows:

Power OFF: No power source connected to the system. I/Os should not be driven high by an external device during this state.

Standby: In the standby state, only the RTC portion of the GS1011 chip is powered from the VBAT pin. The other power supplies are turned off by the DC_DC_CNTL pin being low. Power supplies that MUST be powered on and off together, controlled by the DC_DC_CNTL pin, include the EN_1V8 pin (which controls VOUT_1V8), VDDIO, and (for the GS1011MEx but not the GS1011MIx) the VIN_3V3 pin.

In standby state, the 32.768KHz oscillator keeps running and only the RTC RAM retains the state. SRAM, CPUs and I/Os are all in OFF state, as there is no 1.8V and no VDDIO being supplied to the GS1011 device. I/O pins (except alarms) should not be driven high by an external device during standby state due to diodes in the internal ESD protection

circuitry. Driving I/O pins high during standby could result in incorrect operation on exit from standby state.

This is the lowest-power-consumption state. In a typical application, the system returns to the Standby state between periods of activity, to keep the average power very low and enable years of operation using conventional batteries. During standby, the RTC isolates itself from the rest of the chip, since the signals from the rest of the chip are invalid. This prevents corruption of the RTC registers.

Exit from standby occurs when a pre-specified wakeup time occurs, or when one of the two alarm pins sees the programmed polarity of signal edge. When one of the wakeup conditions occurs, the RTC asserts reset to the chip and sets the DC_DC_CNTL pin high to enable power to the rest of the module. After 3mS, the power to the rest of the module is assumed to be good, the isolation between the RTC and the rest of the chip is released, and the EXT_RESETn pin is released. The WLAN CPU now runs at 32KHz up to 10mS until the 44MHz oscillator is stable, at which time it switches over to running at 22MHz. Another ~25mS are required to initialize the application software.

Note that the alarm pins are strictly edge detected, and cannot be read like GPIO pins. If it is necessary to read the DC level of an alarm input, the signal must be connected to a GPIO pin thru an over-voltage tolerant buffer, powered from VDDIO, so that it stops driving the GPIO pin when VDDIO is turned off in standby mode.

Note: During first battery plug, i.e. when power is applied the first time to the RTC power rail (VBAT), the power detection circuit in the RTC also causes a wakeup request. The RTC startup latency will be at least a couple of hundred ms (and may be as much as 3 seconds) as it is waiting for stabilization of the 32KHz crystal. After the oscillator startup delay, at first battery plug, there is a 7.8mS delay for power to be assumed good and a 31.25mS delay for 44MHz oscillator startup. These delays are reduced for subsequent startups by the first battery plug software. Again, ~25mS are required to initialize the application software.

System Configuration: When a power-up is requested, the system transitions from the Standby state to the System Configuration state. In this state, the WLAN CPU is released from reset by the RTC. The APP CPU remains in the reset state during System Configuration. The WLAN CPU then executes the required system configurations, releases the APP CPU from reset, and transitions to the Power-ON state.

The System Configuration state is also entered on transition from the Power-ON state to the Standby state, to complete necessary preparations before shutting off the power to the core system. Finally, the System Configuration state is used for firmware updates.

Power-ON: This is the active state where all system components can be running. The Power-ON state has various sub-states, in which unused parts of the system can be in sleep mode, reducing power consumption. Sleep states are implemented by gating the clock signal off for a specific system component.

Sleep: In the Sleep state, the 44MHz crystal remains running, but it is gated off to one or both CPUs. Each CPU can independently control its own entry into Sleep state. Any enabled interrupt will cause the interrupted CPU to exit from Sleep state, and this will occur within a few clock cycles.

Deep Sleep: Deep sleep is entered only when both CPUs agree that the wakeup latency is OK. In Deep Sleep mode, the 44MHz crystal oscillator is turned off to save power, but all power supplies remain turned on. Thus all registers, memory, and I/O pins retain their state. Any enabled interrupt will cause an exit from Deep Sleep state, but this now requires startup of the 44MHz oscillator, which requires up to 10mS.

The following are not system states, but are related design notes:

Power Control: The GS1011 chip was designed with the intent that power to the non-RTC portions of the chip be controlled from the DC_DC_CNTL signal. In applications where it is preferred that an external host control the power, this is OK if ALL power, including VBAT power, is turned on and off by the external host. In this case, all state is lost when power goes off, and the latencies from first battery plug apply.

If these latencies are not acceptable, then the GS1011 chip MUST control power. The external host would use an alarm to wake it up, and a serial command to put it into standby. And the DC_DC_CNTL pin would control the power supplies. It is NOT reliable for the external host to directly control the power supplies if VBAT is to be left turned on. This is because the RTC would not know when to isolate itself from the rest of the chip, and might get corrupted during power up or power down.

EXT_RESETn pin: If the external host is driving the EXT_RESETn pin, it MUST do so with an open drain driver. This is because this pin also must be able to be driven low by the RTC and by the voltage monitor chip on the GS module. In addition, if an external host is connected to the EXT_RESETn pin, there must be an external 10K ohm pull-up resistor on the board, pulling up to VDDIO. This is needed to overcome a possible pull-down in the host at first power application. It is also recommended that the host not actively assert EXT_RESETn until all the startup latencies have expired.

One possible usage of the EXT_RESETn pin by an external host is to monitor the pin as an input to detect when the 32KHz oscillator has started up after first application of VBAT power. When the EXT_RESETn pin goes high, the oscillator has started. Under most conditions, this will be considerably faster than the 3 second worst case.

It should also be noted that the constraint that I/O pins not be driven high during standby also applies to the EXT_RESETn pin. It should be pulled only to VDDIO, which shuts off in standby mode.

For more information, consult the GS1011 Peripheral and Register Description [2] and GS1011 SoC data sheet [3] for detailed descriptions.

2.5 Power Supply

In this section, diagrams are shown for various application power supply connection.

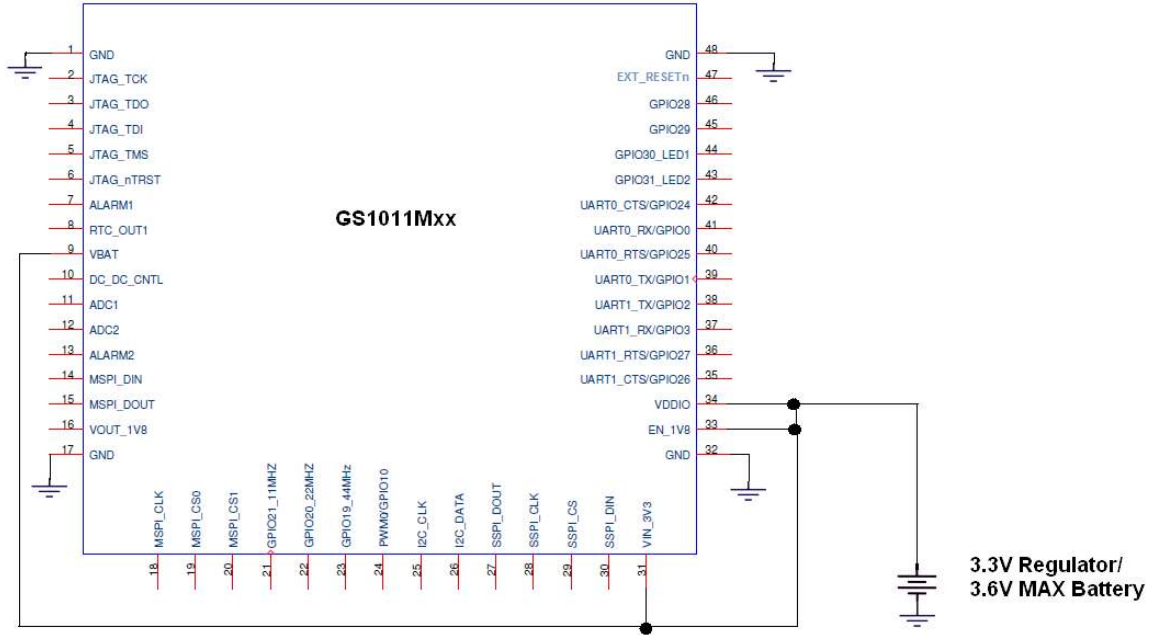

Figure 2-4 : GS1011Mxx Always ON Power Supply Connection

Notes:

- 1) Always On is obtained by tying EN_1V8 to 1 which is the enable for the 1.8V voltage regulator.
- 2) In this state system can still go to deep sleep state and take advantage of low power consumption, but system will not go into the lowest power consumption state (i.e. standby state).

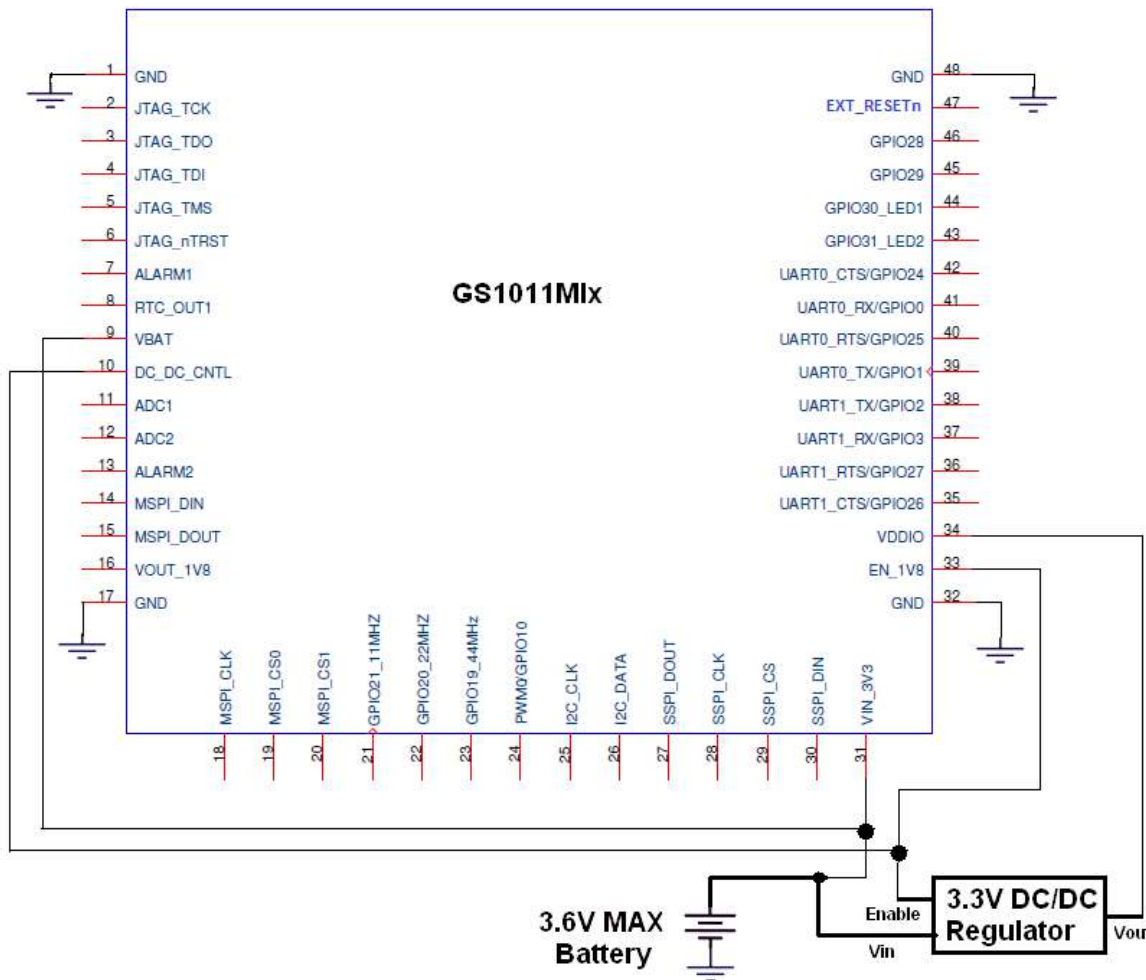

Figure 2-5: GS1011Mix Battery Powered with 3.3V IO and Standby Support

This connection applies for designs (typically battery operated) using GS1011MI module and want to utilize standby (lowest current consumption) state of the module. In this connection it is important to note the following:

- 1) Input voltage to VBAT must always be ON to keep the RTC powered so that the 32KHz crystal is running.
- 2) VDDIO power should be OFF during this state. Recommendation is to use DC_DC_CNTL to also control the unit supplying the voltage to VDDIO
- 3) DC_DC_CNTL must be connected to EN_1V8 to so that the internal 1.8V regulator gets turned OFF when system goes to standby state (i.e. DC_DC_CNTL is de-asserted).

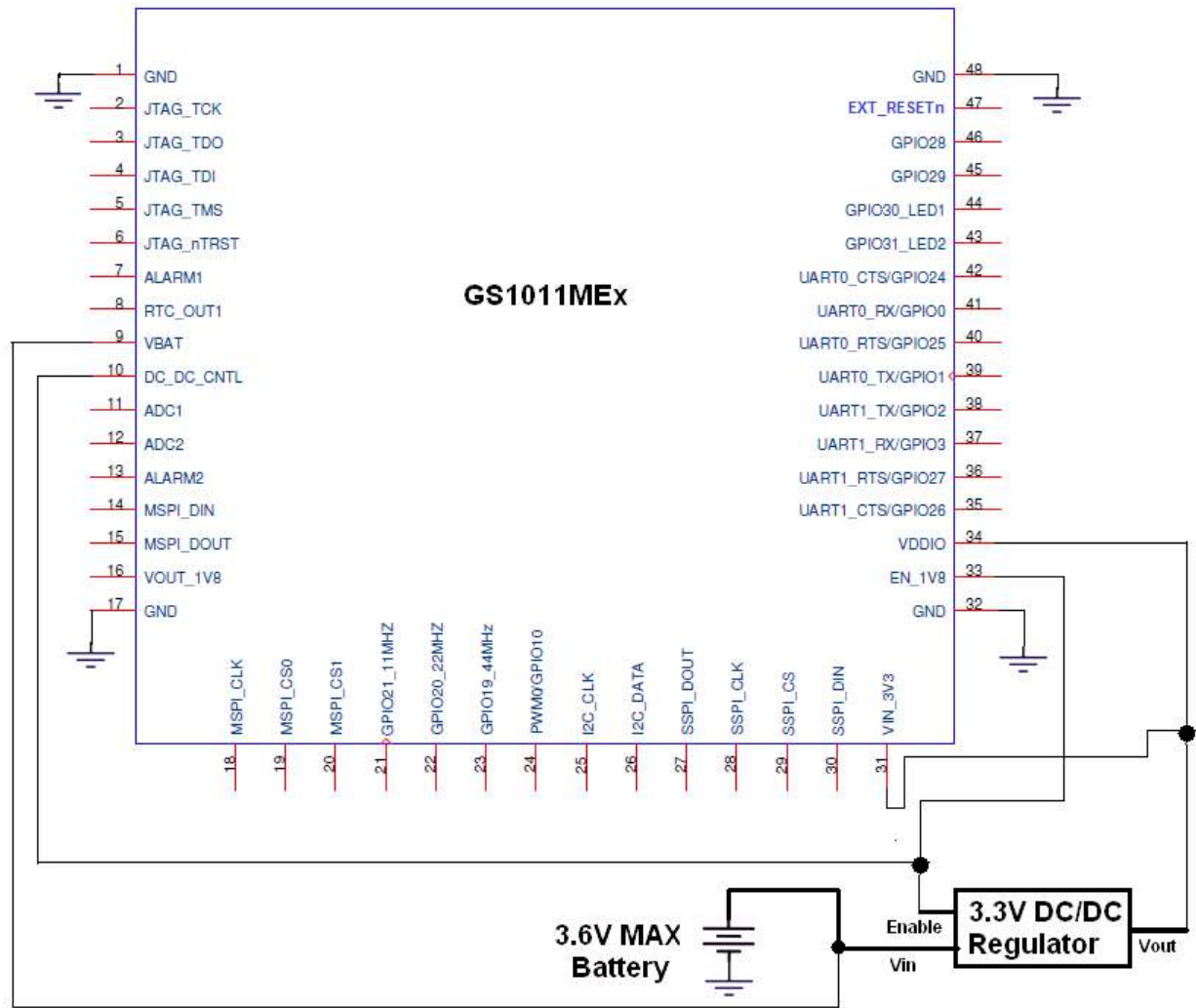

Figure 2-6 : GS1011ME Battery Powered with 3.3V IO and Standby Support

Applications that require Standby Mode and use GS1011ME MUST use this connection configuration to take advantage of the lowest power consumption during standby mode. In this connection it is important to note the following:

- 1) GS1011ME, module PA is supplied with VIN_3V3 and in-rush current for PA transmission; thus, the 3.3V DC/DC Regulator may have to be an Up/Down regulator depending on the battery used
- 2) For GS1011ME, VDDIO and VIN_3V3 power MUST be shut OFF in standby mode so there is no leakage from PA device and thus achieve the lowest current consumption.

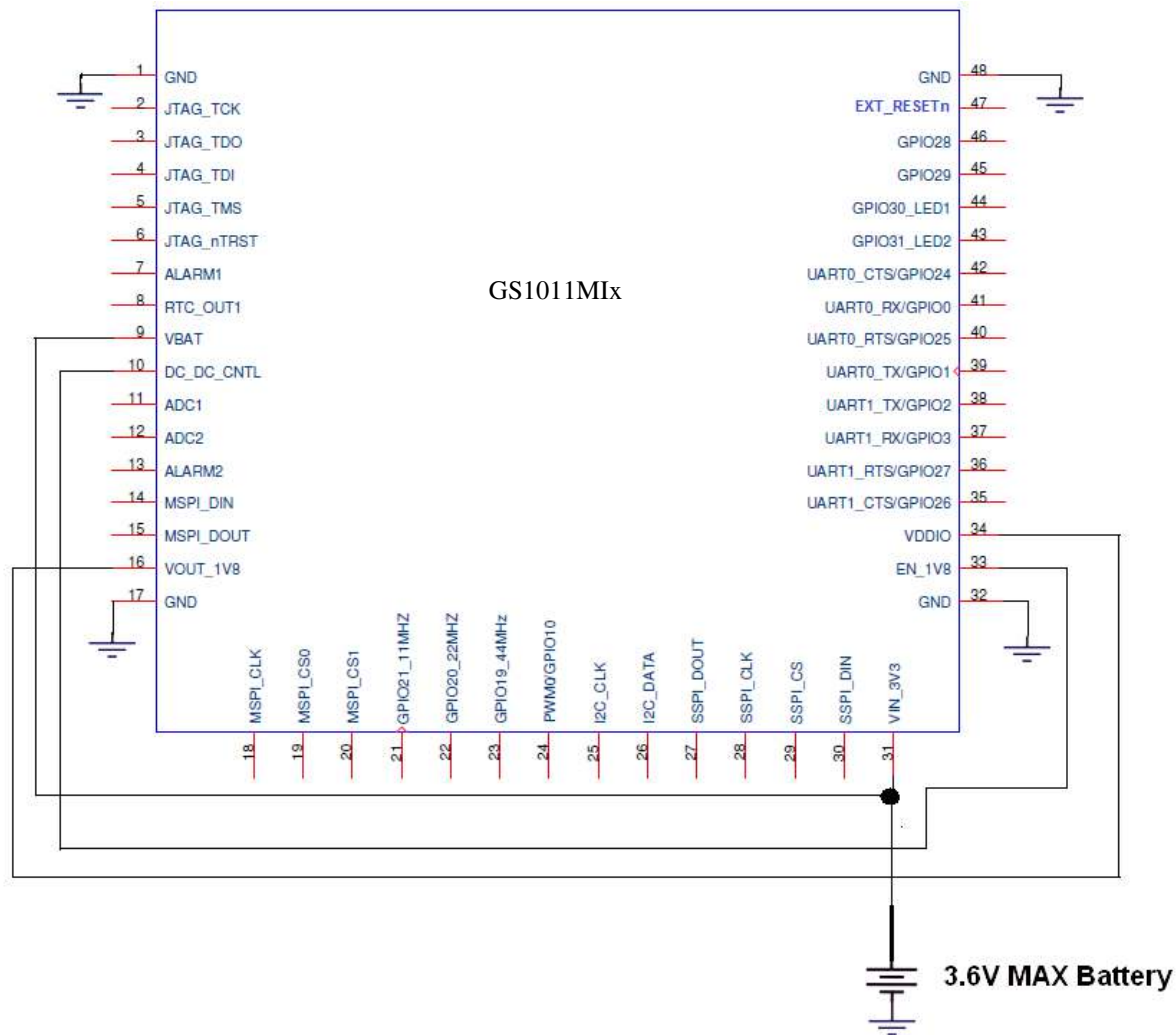

Figure 2-7 : GS1011MI Battery Powered with 1.8V only and Standby Support

This connection applies only to GS1011MI based designs that want standby support and use 1.8V power.

- 1) DC_DC_CNTL should be tied to EN_1V8 to turn off the built-in 1.8V regulator in standby mode. This keeps the current consumption to the minimum

2.5.1 Power Supply Connection Summary

Module	Standby Support required	1V8_EN Connection	VIN_3V3 in Standby	VDDIO	VDDIO in Standby	Standby Wake-Up Latency	Refer to Figure
GS1011MI	No (always on or deep sleep)	Supply Voltage	ON	3.3V	ON	NA	Fig 2.4
GS1011MI	Yes	DC_DC_CNTL	ON	3.3V	OFF	< 15ms	Fig 2.5
GS1011MI	Yes	DC_DC_CNTL	ON	1.8V	OFF	< 15ms	Fig 2.7
GS1011ME rev 1.1	Yes	DC_DC_CNTL	OFF	3.3V	OFF	< 15ms	Fig 2.6

GS1011ME rev 1.1	No (always on or deep sleep)	Supply Voltage	ON	3.3V	ON	NA	Fig 2.4
------------------	------------------------------	----------------	----	------	----	----	---------

For designs that plan to use standby and would like to use a single baseboard that supports either the GS1011MI or GS1011ME module, then they should follow Figure 2-8 example for connections.

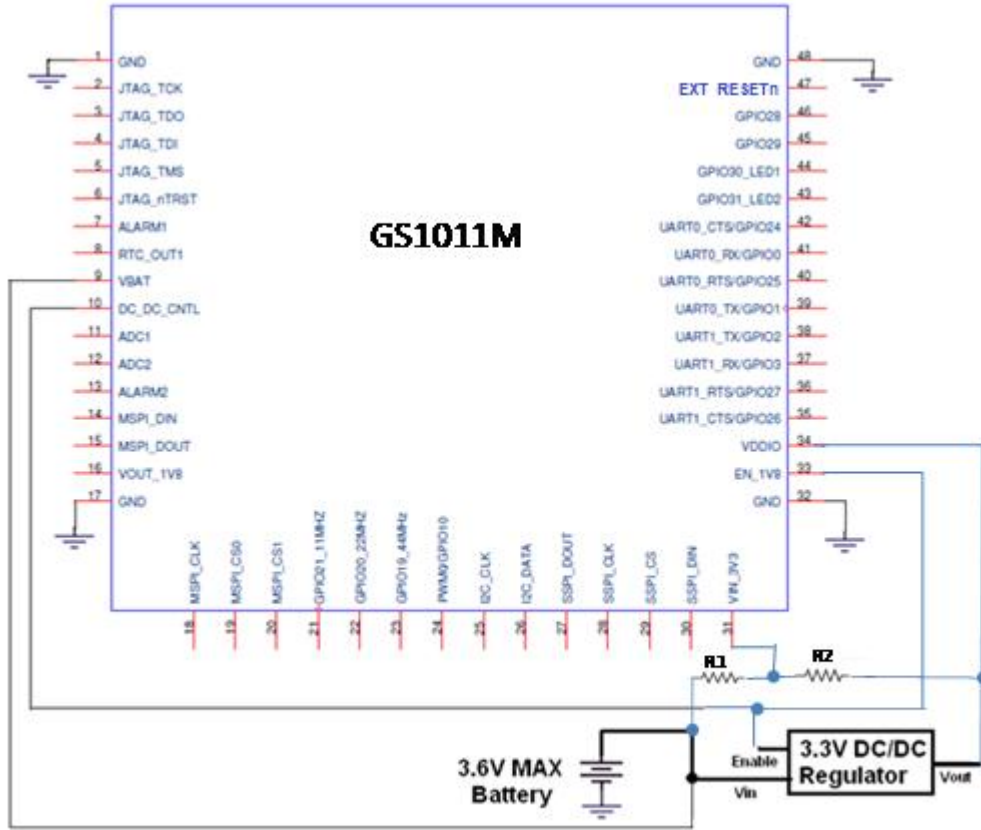

Figure 2-8: Single board design using either GS1011MI or GS1011ME modules with Standby Support

Resistor R1 and R2 are stuffing options depending on the type of Module used. See table below:

Module	Stuffing Option	Equivalent Circuit
GS1011MI	R1 Only	Fig 2.5
GS1011ME	R2 Only	Fig 2.6

3 Pin-out and Signal Description

3.1 GS1011Mxx Device Pin-out Diagram (Module top view)

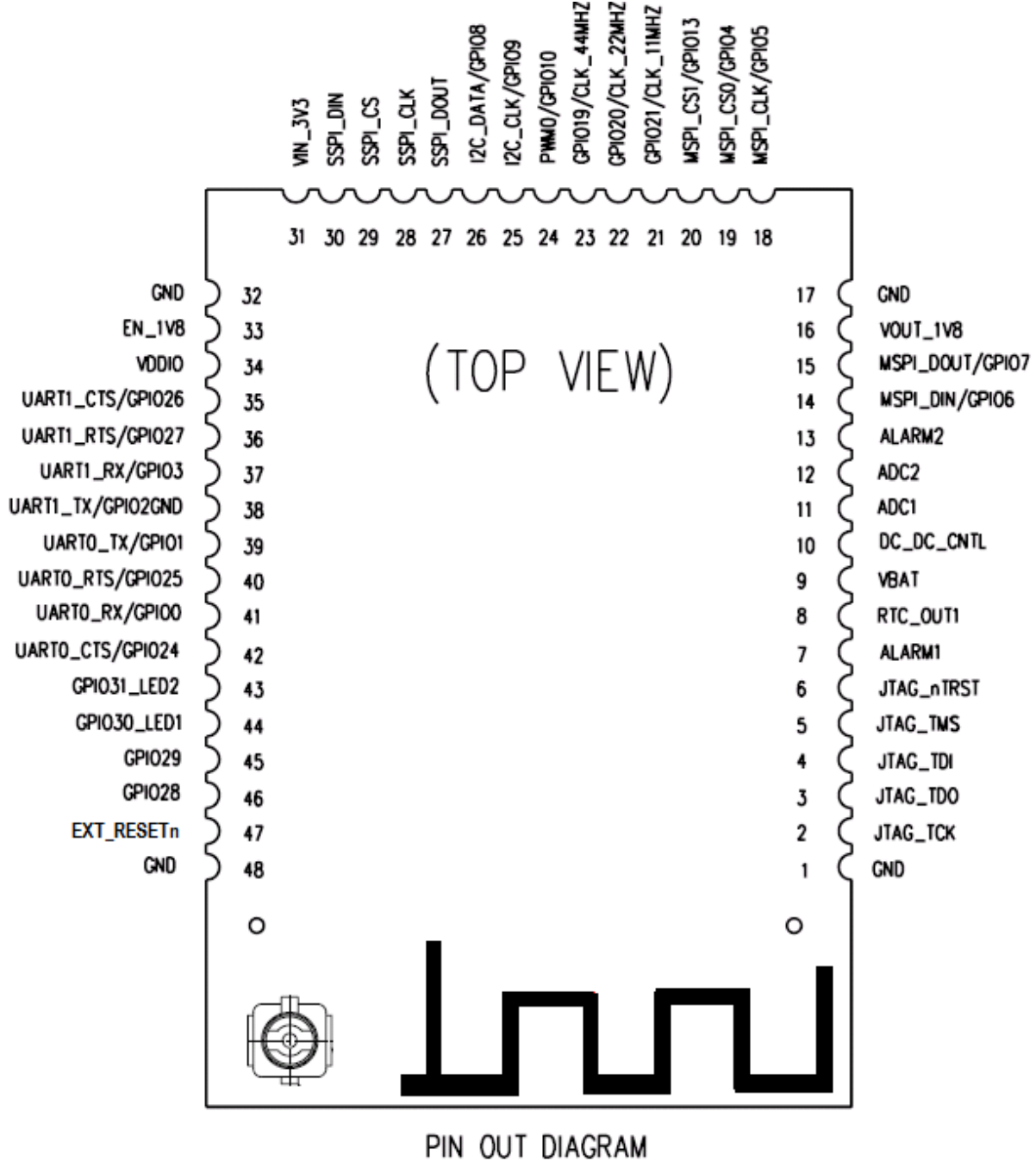

Figure 3-1: GS1011Mxx Device Pin-out Diagram (Module top view)

3.1.1 GS1011Mxx Module Pins Description

Pins	Name	Voltage Domain	Internal Bias after hardware reset	Signal State	Description
1	GND	0V	Not Applicable	Analog port	Ground
2	JTAG_TCK	VDDIO	Pull-up (See Note 1)	Digital Input	Joint Test Action Group Test Clock
3	JTAG_TDO	VDDIO	Not Applicable	Digital Output	Joint Test Action Group Test Data Out
4	JTAG_TDI	VDDIO	Pull-up (See Note 1)	Digital Input	Joint Test Action Group Test Data In
5	JTAG_TMS	VDDIO	Pull-up (See Note 1)	Digital Input	Joint Test Action Group Test Mode Select
6	JTAG_nTRST	VDDIO	Pull-up (See Note 1)	Digital Input	Joint Test Action Group Test Mode Reset Active Low
7	ALARM1	VBAT	Pull-down (See Note 1)	RTC Input	Embedded Real Time Clock Wake Up Input 1
8	RTC_OUT1	VBAT	Not Applicable	RTC Output	Embedded Real Time Clock Wake Up Output 1
9	VBAT	VBAT	Not Applicable	Analog port	Embedded Real Time Clock Power Supply
10	DC_DC_CNTL	VBAT	Not Applicable	Digital Output	VIN_3V3 Regulator Control Output
11	ADC1	VDD18 (internal)	Not Applicable	Analog Input	General Analog to Digital Converter 1
12	ADC2	VDD18 (internal)	Not Applicable	Analog Input	General Analog to Digital Converter 2
13	ALARM2	VBAT	Pull-down (See Note 1)	RTC Input	Embedded Real Time Clock Wake Up Input 2
14	MSPI_DIN / GPIO6	VDDIO	Pull-down	Digital Input / Output	Master Serial Peripheral Interface Bus Data Input / General Purpose Input Output
15	MSPI_DOUT / GPIO7	VDDIO	Pull-down	Digital Input / Output	Master Serial Peripheral Interface Bus Data Output / General Purpose Input Output
16	VOUT_1V8	VIN_3V3 (internally regulated)	Not Applicable	Analog port	Internal 1.8V Vout
17	GND	0V	Not Applicable	Analog port	Ground
18	MSPI_CLK / GPIO5	VDDIO	Pull-down	Digital Input / Output	Master Serial Peripheral Interface Bus Clock / General Purpose Input Output
19	MSPI_CS0 / GPIO4	VDDIO	Pull-down	Digital Input / Output	Master Serial Peripheral Interface Bus Chip Select 0 / General Purpose Input Output
20	MSPI_CS1 / GPIO13	VDDIO	Pull-down	Digital Input / Output	Master Serial Peripheral Interface Bus Chip Select 1 / General Purpose Input Output
21	GPO21_11MHZ	VDDIO	Pull-down	Digital Input / Output	Internal Clock Circuitry Test Point / General Purpose Input Output
22	GPO20_22MHZ	VDDIO	Pull-down	Digital Input / Output	Internal Clock Circuitry Test Point / General Purpose Input Output

Pins	Name	Voltage Domain	Internal Bias after hardware reset	Signal State	Description
23	GPO19_44MHZ	VDDIO	Pull-down	Digital Input / Output	Internal Clock Circuitry Test Point / General Purpose Input Output
24	PWM0 / GPIO10	VDDIO	Pull-down	Digital Input / Output	Pulse Width Modulator / General Purpose Input Output
25	I2C_CLK/GPIO9	VDDIO	Pull-down (NOTE 4)	Digital Input / Output	Inter-Integrated Circuit Clock / General Purpose Input Output
26	I2C_DATA/GPIO8	VDDIO	Pull-down (NOTE 4)	Digital Input / Output	Inter-Integrated Circuit Data / General Purpose Input Output
27	SSPI_DOUT	VDDIO	Pull-up (See Note 1)	Digital Output	SPI Slave Transmit Data Output to the HOST
28	SSPI_CLK	VDDIO	Pull-up (See Note 1)	Digital Input	SPI Slave Clock Input from the HOST
29	SSPI_CS	VDDIO	Pull-up (See Note 1)	Digital Input	SPI Slave Chip Select Input from the HOST
30	SSPI_DIN	VDDIO	Pull-down (See Note 1)	Digital Input	SPI Slave Receive Data Input from the HOST
31	VIN_3V3	VIN_3V3	Not Applicable	Analog port	Single Supply Port
32	GND	0V	Not Applicable	Analog port	Ground
33	EN_1V8	VDDIO	Need to be driven HIGH or LOW externally	Digital Input	Internal 1.8V regulator enable port-Active High
34	VDDIO	VDDIO	Not Applicable	Analog port	All I/O voltage domain (can be tied to VIN_3V3 or tied to HOST I/O supply)
35	UART1_CTS / GPIO26	VDDIO	Pull-down	Digital Input / Output	Universal Asynchronous Receiver Transmitter 1 Clear to Send Input (See Note 6) / General Purpose Input Output
36	UART1_RTS / GPIO27	VDDIO	Pull-down (See Note 2)	Digital Input / Output	Universal Asynchronous Receiver Transmitter 1 Request to Send Output (See Note 6) / General Purpose Input Output
37	UART1_RX / GPIO3	VDDIO	Pull-down	Digital Input / Output	Universal Asynchronous Receiver Transmitter 1 Receive Input / General Purpose Input Output
38	UART1_TX / GPIO2	VDDIO	Pull-down	Digital Input / Output	Universal Asynchronous Receiver Transmitter 1 Transmitter Output / General Purpose Input Output
39	UART0_TX / GPIO1	VDDIO	Pull-down	Digital Input / Output	Universal Asynchronous Receiver Transmitter 0 Transmitter Output / General Purpose Input Output
40	UART0_RTS / GPIO25	VDDIO	Pull-down	Digital Input / Output	Universal Asynchronous Receiver Transmitter 0 Request to Send Output (See Note 6) / General Purpose Input Output
41	UART0_RX / GPIO0	VDDIO	Pull-down	Digital Input / Output	Universal Asynchronous Receiver Transmitter 0 Receive Input / General Purpose Input Output

Pins	Name	Voltage Domain	Internal Bias after hardware reset	Signal State	Description
42	UART0_CTS / GPIO24	VDDIO	Pull-down	Digital Input / Output	Universal Asynchronous Receiver Transmitter 0 Clear to Send Input (See Note 6) / General Purpose Input Output
43	GPO31_LED2	VDDIO	Pull-down	Digital Input / Output	Light Emitting Diode Driver / General Purpose Input Output
44	GPIO30_LED1	VDDIO	Pull-down	Digital Input / Output	Light Emitting Diode Driver / General Purpose Input Output
45	GPIO29	VDDIO	Pull-down (See Note 3)	Digital Input / Output	General Purpose Input Output
46	GPIO28	VDDIO	Pull-down (See Note 3)	Digital Input / Output	General Purpose Input Output
47	EXT_RESETh (See Note 5)	VDDIO	Pull-up	Digital Open Drain Input / Output	Module Hardware Reset Input and Power Supply Reset Monitor Indicator Active Low
48	GND	0V	Not Applicable	Analog port	Ground

Table 3-1: Signal Description

Notes:

1. These pins have onboard hardware configured pull-ups/downs and cannot be changed by software.
2. If UART1_RTS (GPIO27) is high during reset or power on, then the GS1011M will wait for Flash download via UART0 or SSPI interface. Route this pin on the base board so it can be pulled up to VDDIO for programming the module.
3. GPIO 28 and 29 are sampled at reset to establish JTAG configuration for debugging. These signals should not be driven from an external device. If using JTAG, configure these pins as outputs.
4. If I²C interface is used, provide 2K Ohm pull-ups, to VDDIO, for pins 25 and 26 (I2C_CLK and I2C_DATA)
5. EXT_RESETh is an active low signal. It is an output during power up, indicating to the system when GS1011 device is out of power-on-reset. After power-on-reset, this pin is an input. It is not necessary to assert reset to the GS1011M after power on, since the GS1011 has a built-in power on reset. Also, the EXT_RESETh signal does not clear the RTC RAM or the SRAM. If the external host is driving the EXT_RESETh pin, it MUST do so with an open drain driver. This is because this pin also must be able to be driven low by the RTC and by the voltage monitor chip on the GS module. In addition, if an external host is connected to the EXT_RESETh pin, there must be an external 10K ohm pull-up resistor on the board, pulling up to VDDIO.
6. CTS and RTS signals indicate it is clear to send or ready to send when they are LOW. If signals are high, indicates device is not ready.

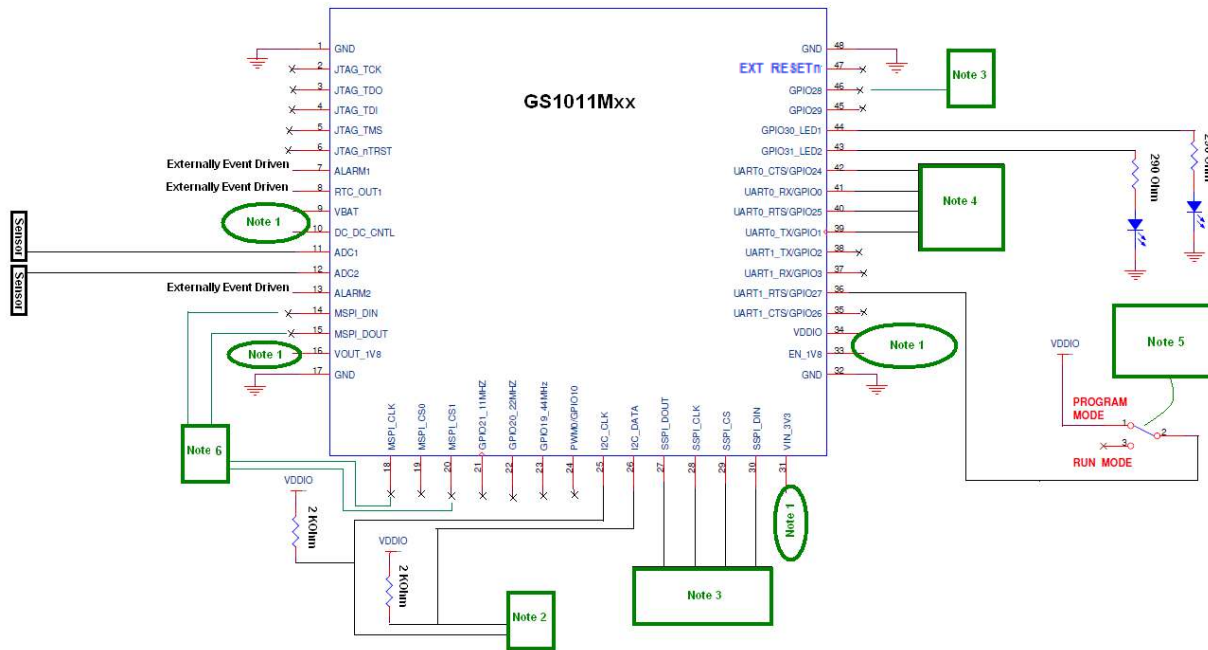

Figure 3-2: Module pin connection diagram

- Note 1) For the noted pin configurations, please refer to data sheet power supply section.
- Note 2) If I²C interface is used, provide 2K0 Ohm pull-ups, to VDDIO, for pins 25 and 26 (I2C_CLK and I2C_DATA). If not used, leave pins 25 and 26 as No Connects.
- Note 3) Connect to external HOST SPI (can be left as No Connects if not used).
- Note 4) Connect to external serial HOST UART (can be left as No Connections if not used)
- Note 5) Modules ship with only test firmware and so design must bring out this pin so to enable programming of GS1011M onboard flash. Switch is recommended for development purposes. For production it is recommended designers provide option to pull this pin (GPIO27) high during reset or power-on for in-circuit programming of the module.
- Note 6) The need for external flash memory depends on advanced firmware features selected/required such as factory backup, a more robust over-the-air firmware update, or web pages. The serial flash memory should be instruction set compliant with Micron M25P80. See module design guidelines document for supported flash sizes and devices.

4 Electrical Characteristics

4.1 Absolute Maximum Ratings

Conditions beyond those cited in Table 4-1 may cause permanent damage to the GS1011MXX, and must be avoided. Sustained operation, beyond the normal operating conditions, may affect the long term reliability of the module.

Parameter	Symbol	Minimum	Typical	Maximum	Unit
Storage temperature	T _{ST}	-55		+125	°C
RTC Power Supply	Vbat	-0.5		4.0	V
I/O Supply voltage	VDDIO	-0.5		4.0	V
Single Supply Port	VIN_3V3	0.5	3.3	4.0	V
Signal Pin Voltage ¹	VI	-0.3		Voltage Domain + 0.3	V

Table 4-1: Absolute Maximum Ratings

NOTE: ¹Reference domain voltage is the Voltage Domain per section 3.1.1

For limitations on state voltage ranges, please consult section 3.1.1

4.2 Operating Conditions

Parameter	Symbol	Minimum	Typical	Maximum	Unit
Extended temp. range	T _A	-40		+85	°C
RTC Power Supply	Vbat	1.6	3.3	3.6	V
I/O Supply voltage	VDDIO	1.7	3.3	3.6	V
Single Supply Port GS1011Mlx (as configured per Figure 2-4, 5, & 7)	VIN_3V3	2.7	3.3	3.6	V
Single Supply Port GS1011MEx (as configured per Figure 2-6)	VIN_3V3	3.0	3.3	3.6	V
Signal Pin Voltage ¹	VI	0		Voltage Domain	V

Table 4-2: Operating Conditions

NOTE: ¹Reference domain voltage is the Voltage Domain per section 3.1.1

4.3 Internal 1.8V regulator

VIN_3V3=VDDIO=Vbat=3.3V Temp=25°C fOSC=3.0MHz

Parameter	Symbol	Test conditions	Minimum	Typical	Maximum	Unit
Output Voltage	VOUT_1V8			1.8		V
Maximum Output Current	IVOUT_1V8			30	50	mA
Oscillation Frequency	fOSC		1.6		3.45	MHz
1.8V Regulator Enable "H" Voltage	EN_1V8		1.0		VIN_3V3	V
1.8V Regulator Enable "L" Voltage	EN_1V8		0		0.25	V

Table 4-3: Internal 1.8V Regulator

4.4 I/O DC Specifications

4.4.1 Digital Input Specifications

Parameter	Symbol	Minimum	Typical	Maximum	Unit	Note
Input Low Voltage	V _{IL}	-0.3		0.25* VDDIO	V	
Input High Voltage	V _{IH}	0.8* VDDIO		VDDIO	V	

Table 4-4: Digital Input Parameters

4.4.2 Digital Output Specification

Parameter	Symbol	Minimum	Typical	Maximum	Unit	Note
Output Low Voltage	V _{OL}	0		0.4	V	With 4 mA load
Output High Voltage	V _{OH}	2.4V		VDDIO	V	V _{DDIO} =3.0V, DC current load 4.0 mA
		1.3V				V _{DDIO} =1.62 V, DC current load 2.0 mA
Output rise time @ VDDIO=3.3V	t _{TLH}			7	ns	With 4 mA, 33 pF load
Output fall time @ VDDIO=3.3V	t _{THL}			7	ns	With 4 mA, 33 pF load

Table 4-5: Digital Output Parameters

4.4.3 I/O Digital Specifications (Tri-State)

Parameter	Symbol	Minimum	Typical	Maximum	Unit	Note
Input Low Voltage	V_{IL}	-0.3		$0.25 \cdot V_{DDIO}$	V	
Input High Voltage	V_{IH}	$0.8 \cdot V_{DDIO}$		V_{DDIO}	V	
Schmitt trig. Low to High threshold point	V_{T+}	1.5			V	
Schmitt trig. High to Low threshold point	V_{T-}			1	V	
Input Leakage Current	I_L			5	μA	Pull up/down disabled
Tri-State Output Leakage Current	Oz_L			5	μA	Pull up/down disabled
Pull-Up Resistor	R_u	0.05		1	$M\Omega$	
Pull-Down Resistor	R_d	0.05		1	$M\Omega$	
Output Low Voltage	V_{OL}	0		0.4	V	With 4/12/20 mA load
Output High Voltage	V_{OH}	2.4V		V_{DDIO}	V	$V_{DDIO}=3.0V$ With 4/12/20 mA load
		1.3 V				$V_{DDIO} = 1.62 V$ With 2/6/10 mA load
Output rise time @ $V_{DDIO} = 3.3V$	t_{ToLH}			7	ns	With 4/12/20 mA load, 33 pF
Output fall time @ $V_{DDIO} = 3.3V$	t_{ToHL}			7	ns	With 4/12/20 mA load, 33 pF
Input rise time	t_{TiLH}			7	ns	
Input fall time	t_{TiHL}			7	ns	

Table 4-6: I/O Digital Parameters

4.4.4 RTC Input Specifications (with Schmitt Trigger)

Parameter	Symbol	Minimum	Typical	Maximum	Unit	Note
I/O Supply Voltage	V_{DDRTC}	1.2		Vbat	V	
Input Low Voltage	V_{IL}	-0.3		$0.25 \cdot V_{DDRTC}$	V	
Input High Voltage	V_{IH}	$0.8 \cdot V_{DDRTC}$		V_{DDRTC}	V	
Schmitt trig. Low to High threshold point	V_{T+}	$0.57 \cdot V_{DDRTC}$		$0.68 \cdot V_{DDRTC}$	V	
Schmitt trig. High to Low threshold point	V_{T-}	$0.27 \cdot V_{DDRTC}$		$0.35 \cdot V_{DDRTC}$	V	
Input Leakage Current	I_L		260		pA	

Table 4-7: RTC Input Parameters

4.4.5 RTC Output Specifications

Parameter	Symbol	Minimum	Typical	Maximum	Unit	Note
I/O Supply Voltage	V_{DDRTC}	1.2		Vbat	V	
Output Low Voltage	V_{OL}	0		0.4	V	
Output High Voltage	V_{OH}	$0.8 \cdot V_{DDRTC}$		V_{DDRTC}	V	
Output rise time	t_{TLH}	19		142	ns	50 pF load
Output fall time	t_{THL}	21		195	ns	50 pF load
Input Leakage Current	I_L		730		pA	

Table 4-8: RTC Output Parameters

4.5 Power Consumption (Estimated)

Typical Conditions: $V_{DD33}=V_{DDIO}=V_{bat}=3.3V$ Temp= $25^{\circ}C$; Max is across operating conditions

System state	Current (Typ.)	Current (Max)
Standby	7uA	
Deep Sleep (GS1011MI)	150uA	
Deep Sleep (GS1011ME)	200uA	
Receive (GS1011Mxx; -81 dBm RX sens. @ 11Mb/Sec.)	140mA	
Transmit (GS1011MIx; +9 dBm at antenna port @ 11Mb/Sec.)	150mA	250mA
Transmit (GS1011MEEx; +18 dBm at antenna port @ 11Mb/Sec.)	250mA	350mA

Table 4-9: Power Consumption in Different States

4.6 Radio Parameters

Test Conditions: $V_{IN_3V3}=V_{DDIO}=V_{bat}=3.3V$ Temp= $25^{\circ}C$

Parameter	Minimum	Typical	Maximum	Unit	Notes
RF Frequency range	2412		2497	MHz	
Radio bit rate	1		11	Mbps	Ch 14 max is 2 Mbps
TX/RX specification for GS1011MIx					
Output power (average)		9		dBm	Modulated signal at antenna port; 11Mb/Sec.
Spectrum Mask				dBr	Modulated signal at antenna port
F0 +/- 11 MHz	-30				
Offset >= 22 MHz	-50				
Receive Sensitivity at antenna port		-83 -86 -90 -92		dBm	11 Mbps CCK, 8% PER 5.5 Mbps CCK, 8% PER 2 Mbps QPSK, 8% PER 1 Mbps BPSK, 8% PER

Parameter	Minimum	Typical	Maximum	Unit	Notes
TX/RX specification for GS1011MEx					
Output power (average)		18		dBm	Modulated signal at antenna port; 11Mb/Sec.
Spectrum Mask				dBr	Modulated signal at antenna port
F0 +/- 11 MHz	-30				
Offset >= 22 MHz	-50				
Receive Sensitivity at antenna port		-83		dBm	11 Mbps CCK, 8% PER
100-byte packet		-86			5.5 Mbps CCK, 8% PER
		-90			2 Mbps QPSK, 8% PER
		-92			1 Mbps BPSK, 8% PER

Table 4-10: Radio Parameters

4.7 ADC Parameters

Test Conditions: VIN_3V3=VDDIO=Vbat=3.3V Temp=25°C

Parameter	Minimum	Typical	Maximum	Unit	Notes
ADC Resolution	-	10	-	Bits	
ADC Sample Freq	1.024	-	31.25	ksps	
ADC input Clock Freq	32.768	-	1000	kHz	
ADC Full Scale Voltage	-	$V_{OUT_1V8} - 0.036$	V_{OUT_1V8}	V	Reference = V_{OUT_1V8}
	1.169	1.24	1.311		Reference = bandgap
	3.527	3.73	3.913		Measuring Vbat
Conversion Time		32		Clocks	Based on internally generated 1MHz or 32.768 KHz Clocks
ADC Integral Non-Linearity (INL)	-2.0	-	2.0	LSB	
ADC Differential non-linearity (DNL)	-1.0	-	1.0	LSB	
AVDD Power Supply current (operational)	-	400	800	μA	
ADC Offset Error	-10	-	10	mV	
ADC Gain Error	-10	-	10	mV	
Settling Time		-	1	μS	
Input resistance	1	-	-	MOhm	
Input Capacitance	-	10	-	pF	
Bandgap Output Voltage (Vref) (T = 25 °C)	1.179	1.24	1.301	V	

Table 4-11: ADC Parameters

4.8 SPI Interface Timing

Test Conditions: VIN_3V3=VDDIO=Vbat=3.3V Temp=25°C

4.8.1 Motorola SPI, clock polarity SPO = 0, clock phase SPH = 0

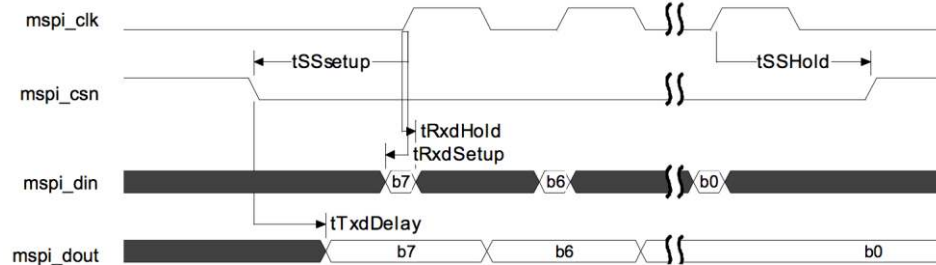

Figure 4-1: timing diagram, Master mode, SPO=SPH=0.

Parameter	Description	Minimum	Maximum	Unit
tSSSetup	Minimum time between falling edge of Select line and first rising edge of SPI clock	1		MSPI clock period
tTxdDelay	Delay in Master asserting TX line after falling edge of Select line		2 core SPI clock periods + 3 nsec	mixed
tRxdSetup	Time before rising edge of SPI clock by which received data must be ready	30		nsec
tRxdHold	Time for which received data must be stable after rising edge of SPI clock	10		nsec
tSSHold	Time for which the Select line will be held after the sampling edge for the final bit to be transferred	1		MSPI clock period

Table 4-12: timing parameters, Master mode, SPO=SPH=0.

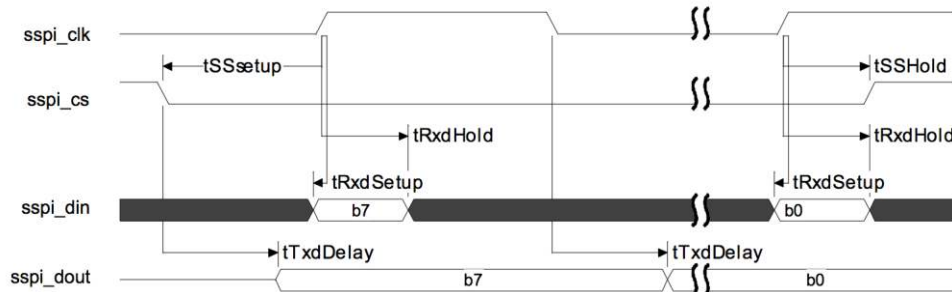

Figure 4-2: timing diagram, Slave mode, SPO=SPH=0.

Parameter	Description	Minimum	Maximum	Unit
tSSSetup	Minimum time between falling edge of Select line and first rising edge of SPI clock.	4 core SPI clock periods + 68 ns		mixed
tTxdDelay	Delay in Slave asserting TX line after falling edge of SPI clock, or the first bit after falling edge of the Select line.		4 core SPI clock periods + 68 ns	mixed
tRxdSetup	Time before rising edge of SPI clock by which received data must be ready	15		ns
tRxdHold	Time for which received data must be stable after rising edge of SPI clock	3 core SPI clock periods + 14 ns		mixed
tSSHold	Time for which the Select line will be held after the sampling edge for the final bit to be transferred	3 core SPI clock periods + 14 ns		mixed

Table 4-13: timing parameters, Slave mode, SPO=SPH=0.

4.8.2 Motorola SPI, clock polarity SPO = 0, clock phase SPH = 1

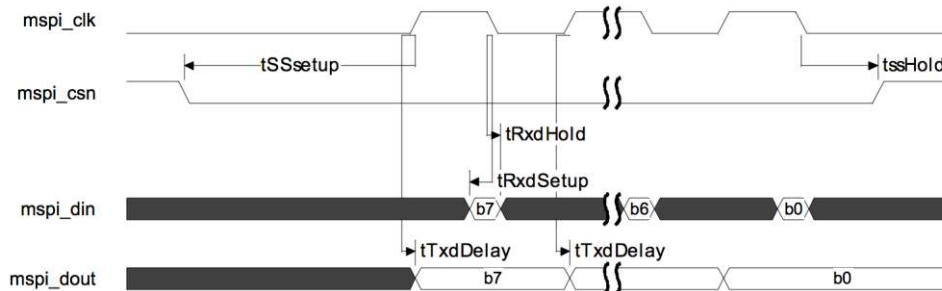

Figure 4-3: timing diagram, Master, SPO=0, SPH=1.

Parameter	Description	Minimum	Maximum	Unit
tSSSetup	Minimum time between falling edge of select line and first rising edge of SPI clock.	1.5		MSPi clock period
tTxdDelay	Delay in Master asserting TX line after rising edge of SPI clock.		0	ns
tRxdSetup	Time before falling edge of SPI clock by which received data must be ready.	30		ns
tRxdHold	Time for which received data must be stable after falling edge of SPI clock.	10		ns
tSSHold	Time for which the Select line will be held low after the sampling edge for the final bit to be transferred.	0.5		MSPi clock period

Table 4-14: timing parameters, Master mode; SPO=0, SPH=1.

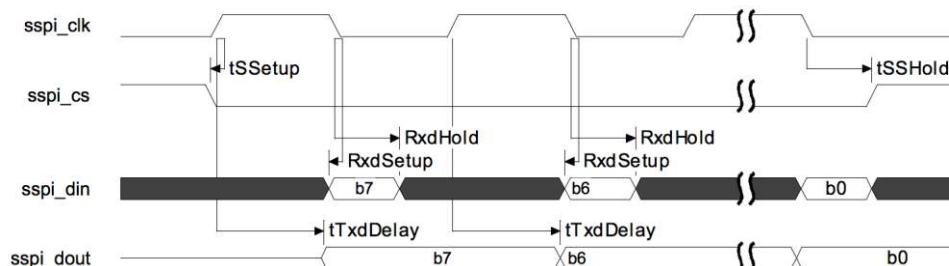

Figure 4-4: timing diagram, Slave, SPO=0, SPH=1.

Parameter	Description	Minimum	Maximum	Unit
tSSetup	Minimum time between falling edge of select line and first rising edge of SPI clock.	15		ns
tTxdDelay	Delay in Slave asserting TX line after rising edge of SPI clock.		4 core SPI clock periods + 68 ns	mixed
tRxdSetup	Time before falling edge of SPI clock by which received data must be ready.	15		ns
tRxdHold	Time for which received data must be stable after falling edge of SPI clock.	3 core SPI clock periods + 14 ns		mixed
tSSHold	Time for which the Select line will be held low after the sampling edge for the final bit to be transferred.	3 core SPI clock periods + 14 ns		mixed

Table 4-15: timing parameters, Slave mode, SPO=0, SPH=1.

4.8.3 Motorola SPI, clock polarity SPO = 1, clock phase SPH = 0

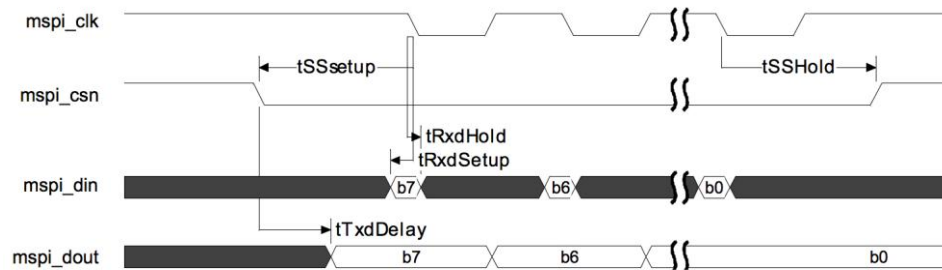

Figure 4-5: timing diagram, Master mode, SPO=1, SPH=0.

Parameter	Description	Minimum	Maximum	Unit
tSSetup	Minimum time between falling edge of select line and first falling edge of SPI clock.	1		MSPi clock period
tTxdDelay	Delay in Master asserting TX line after falling edge of Select line.		2 core SPI clock periods + 3 ns	mixed
tRxdSetup	Time before falling edge of SPI clock by which received data must be ready.	30		ns
tRxdHold	Time for which received data must be stable after falling edge of SPI clock.	10		ns
tSSHold	Time for which the Select line will be held low after the sampling edge for the final bit to be transferred.	1		MSPi clock period

Table 4-16: timing parameters, Master mode, SPO=1, SPH=0.

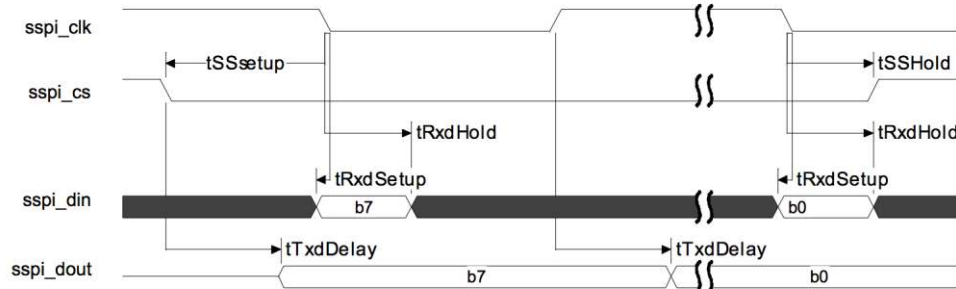

Figure 4-6: timing diagram, Slave mode, SPO=1, SPH=0.

Parameter	Description	Minimum	Maximum	Unit
tSSSetup	Minimum time between falling edge of Select line and first falling edge of SPI clock.	4 core SPI clock periods + 68 ns		Mixed
tTxDelay	Delay in Slave asserting TX line after rising edge of SPI clock, or the first bit after falling edge of the Select line.		4 core SPI clock periods + 68 ns	Mixed
tRxdSetup	Time before falling edge of SPI clock by which received data must be ready.	15		ns
tRxdHold	Time for which received data must be stable after falling edge of SPI clock.	3 core SPI clock periods + 14 ns		Mixed
tSSHold	Time for which the Select line will be held low after the sampling edge for the final bit to be transferred.	3 core SPI clock periods + 14 ns		MSPI clock period

Table 4-17: timing parameters, Slave mode, SPO=1, SPH=0.

4.8.4 Motorola SPI, clock polarity SPO = 1, clock phase SPH = 1

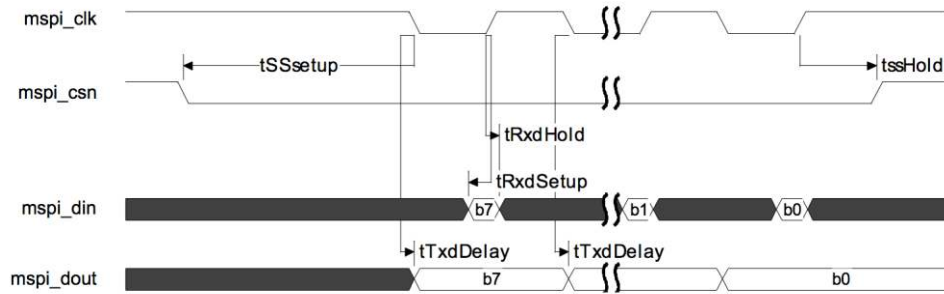

Figure 4-7: timing diagram, Master mode, SPO=SPH=1.

Parameter	Description	Minimum	Maximum	Unit
tSSSetup	Minimum time between falling edge of select line and first falling edge of SPI clock.	1.5		MSPI clock period
tTxdDelay	Delay in Master asserting TX line after falling edge of SPI clock.		0	ns
tRxdSetup	Time before rising edge of SPI clock by which received data must be ready.	30		ns
tRxdHold	Time for which received data must be stable after rising edge of SPI clock.	10		ns
tSSHold	Time for which the Select line will be held low after the sampling edge for the final bit to be transferred.	0.5		MSPI clock period

Table 4-18: timing parameters, Master mode, SPO=SPH=1.

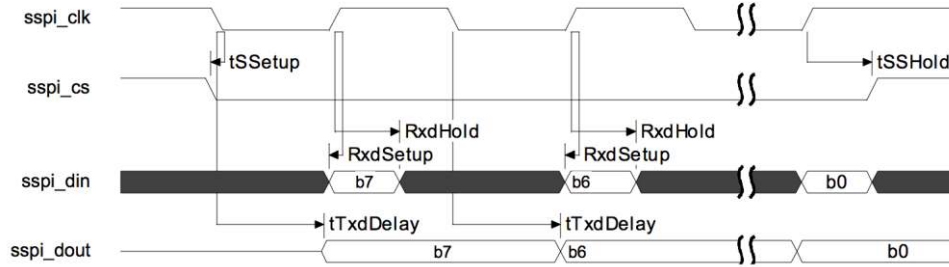

Figure 4-8: timing diagram, Slave mode, SPO=SPH=1.

Parameter	Description	Minimum	Maximum	Unit
tSSetup	Minimum time between falling edge of select line and first falling edge of SPI clock.	15		ns
tTxdDelay	Delay in Slave asserting TX line after falling edge of SPI clock.		4 core SPI clock periods + 68 ns	Mixed
tRxdSetup	Time before rising edge of SPI clock by which received data must be ready.	15		ns
tRxdHold	Time for which received data must be stable after rising edge of SPI clock.	3 core SPI clock periods + 14 ns		Mixed
tSSHold	Time for which the Select line will be held low after the sampling edge for the final bit to be transferred.	3 core SPI clock periods + 14 ns		Mixed

Table 4-19: timing parameters, Master mode, SPO=SPH=1.

5 Package and Layout Guidelines

5.1 GS1011Mxx Recommended PCB Footprint and Dimensions

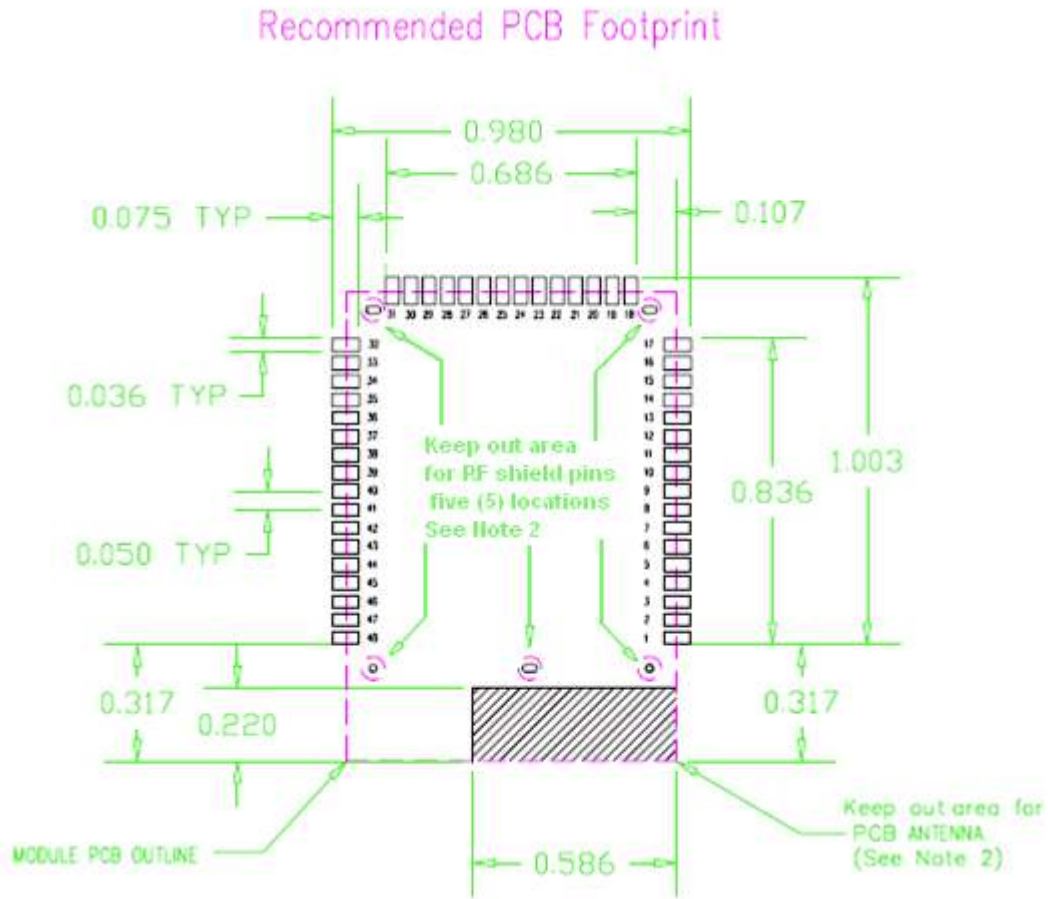

Figure 5-1: GS1011Mxx Module Recommended PCB Footprint (in inches)

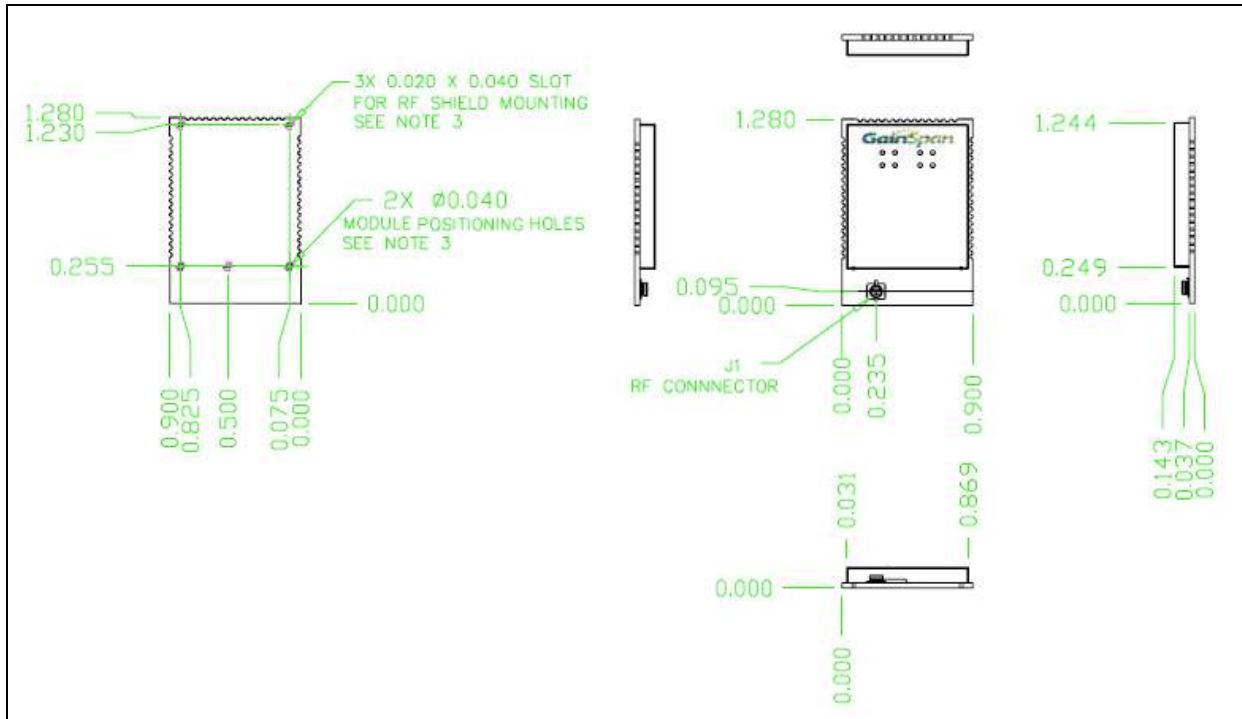

Figure 5-2: GS1011Mx Module Dimensions (in inches)

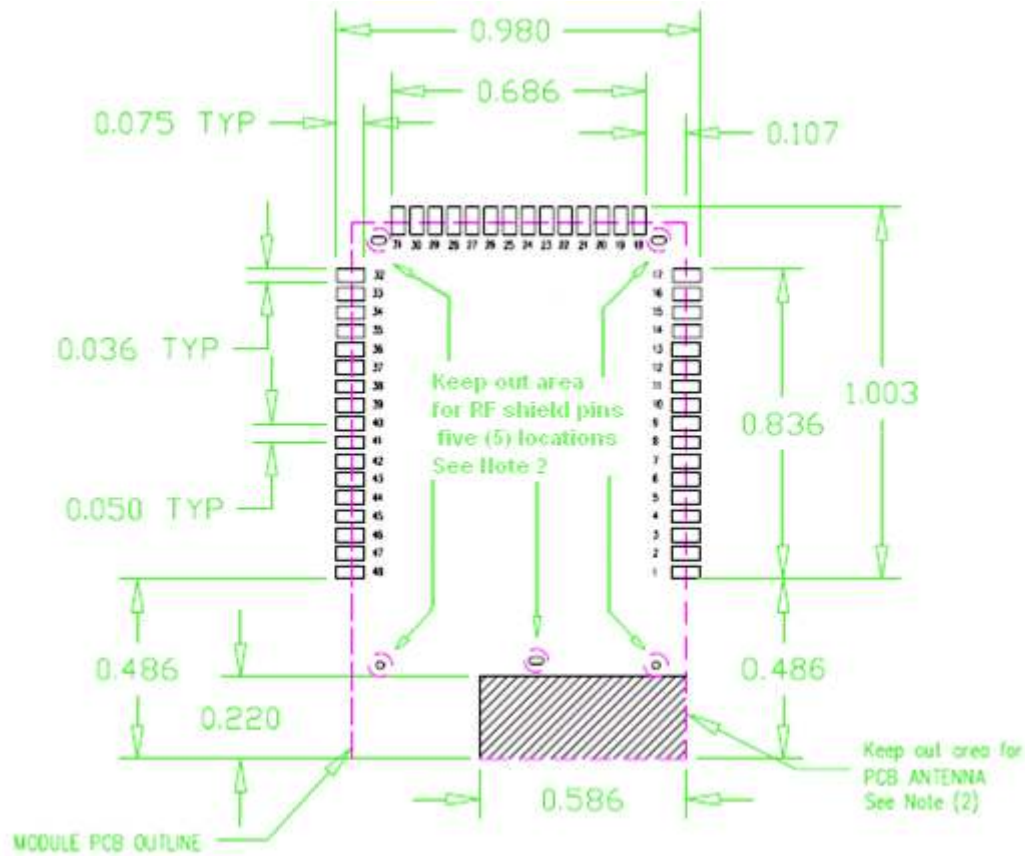

Figure 5-3: GS1011MEx Module Recommended PCB Footprint (in inches)

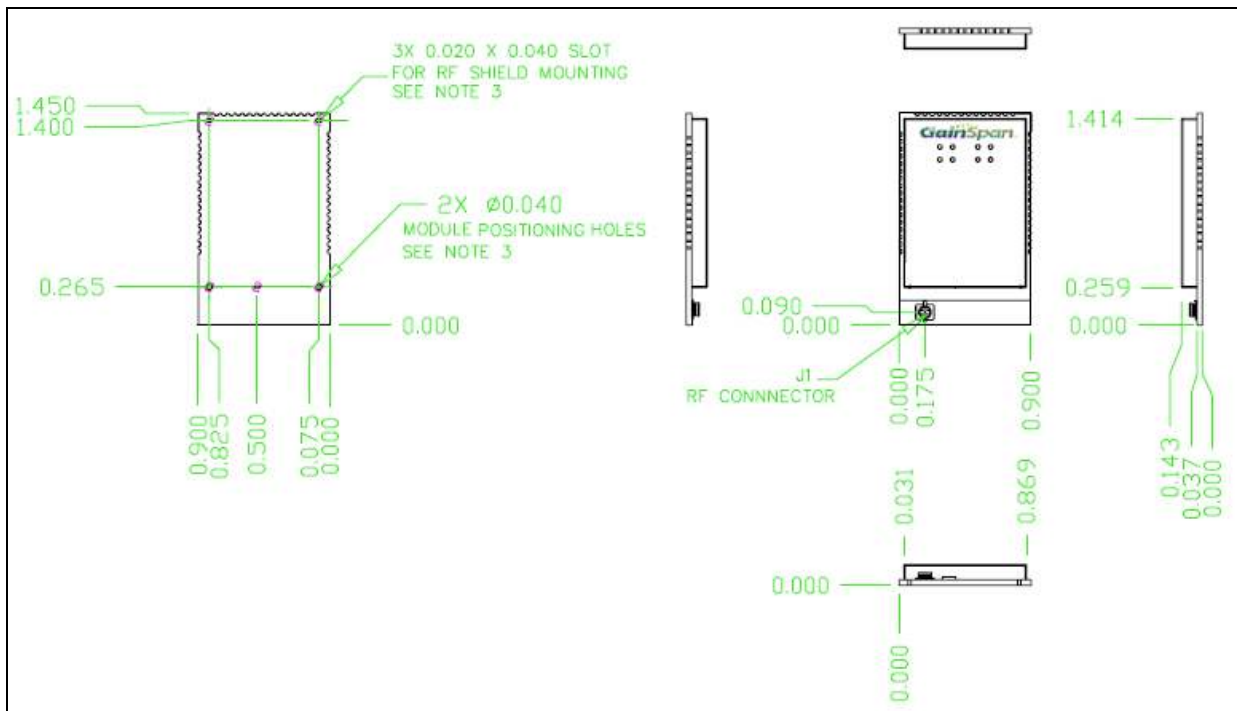

Figure 5-4: GS1011MEx Module Dimensions (in inches)

5.2 GS1011MxP Layout Guidelines

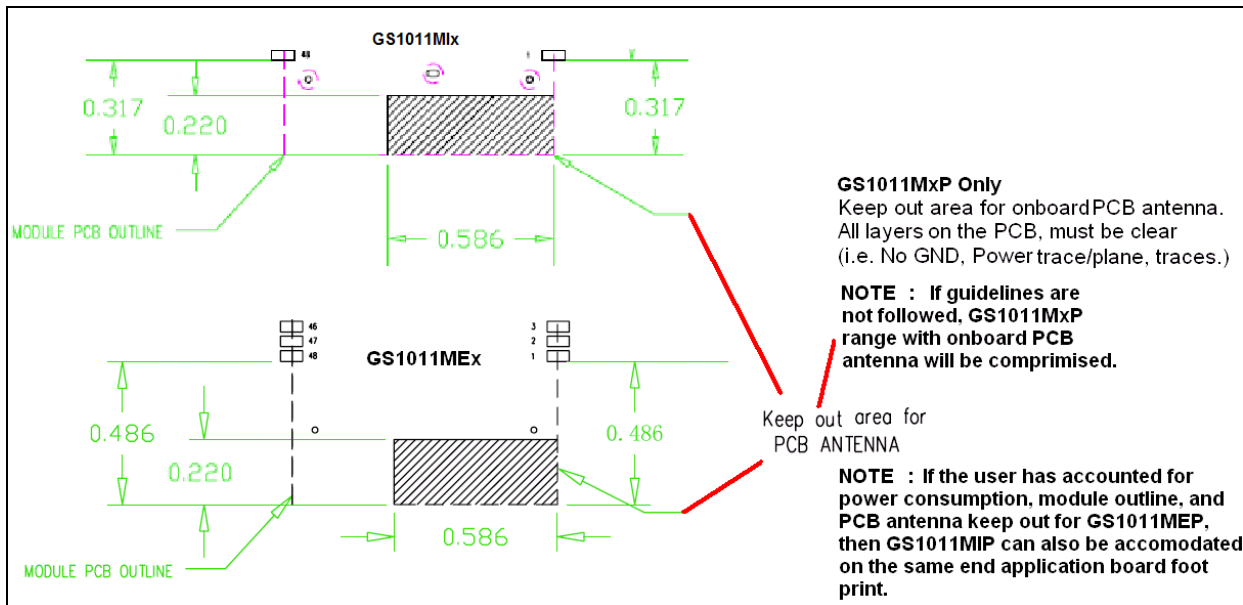

Figure 5-5: GS1011MxP module onboard antenna keep-out layout guidelines (dimensions are in inches)

If application baseboard is being designed to accommodate both GS1011MIP and GS1011MEP, then customer may follow the recommendation as shown in

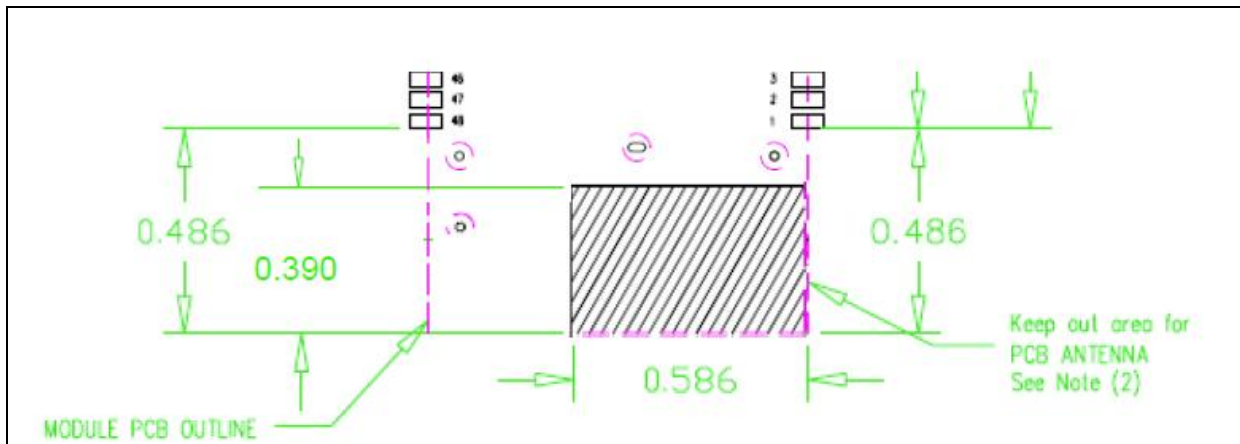

Figure 5-6 Recommended keep out area to accommodate both GS1011MIP and GS1011MEP

Notes:

1. All Dimensions are in inches. Tolerances shall be ± 0.010 inches.
2. Absolutely no metal trace or ground layer underneath this area.
3. It is recommended not to run circuit traces underneath the module especially near these holes; The RF shield mounting holes are grounded. If traces must be routed under the GS1011Mxx, it is recommended that extra thick solder mask (5 mils) be used to prevent shorting. High speed signals should be kept as far as possible from the antenna and RF areas of the GS1011Mxx.
4. In performing SMT or manual soldering of the module to the base board, first align the row of pins from #18 thru 31 onto the base board and then match the other two rows.

In addition to the guidelines in Figure 5-6, note the following suggestions:

GS1011MEx and GS1011MIx

- External Bypass capacitors for all module supplies should be as close as possible to the module pins.
- Never place the antenna very close to metallic objects.
- External monopole antennas need a reasonable ground plane area for antenna efficiency.

GS1011MxP on board PCB antenna specific

- For best RF performance, it is recommended that the PCB antenna hang over the edge of the base board, so that there is no FR4 under it or next to it.
- The PCB antenna keep out area, as shown in Figure 5-4, must be adhered to. Ground plane on the base board should be kept further away if possible, and should not fully enclose the PCB antenna.
- Do not use a metallic or metalized plastic for the end product enclosure.
- Recommendation is to keep plastic enclosure clearance of 1cm from top and bottom of the GS1011M PCB antenna keep-out area, if possible. 5-mm (0.2 in) clearance shall be the minimum as shown in Figure 5-7.

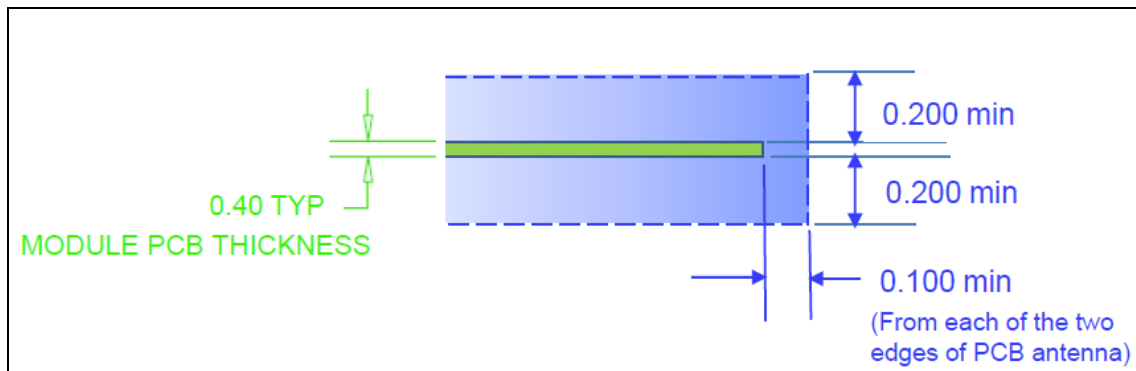

Figure 5-7 Recommended clearance above and below the GS1011MxP trace antenna

5.2.1 Surface Mount Assembly

The reflow profile¹ is shown in Figure 5-8. Recommended reflow parameters are summarized in Table 5-1.

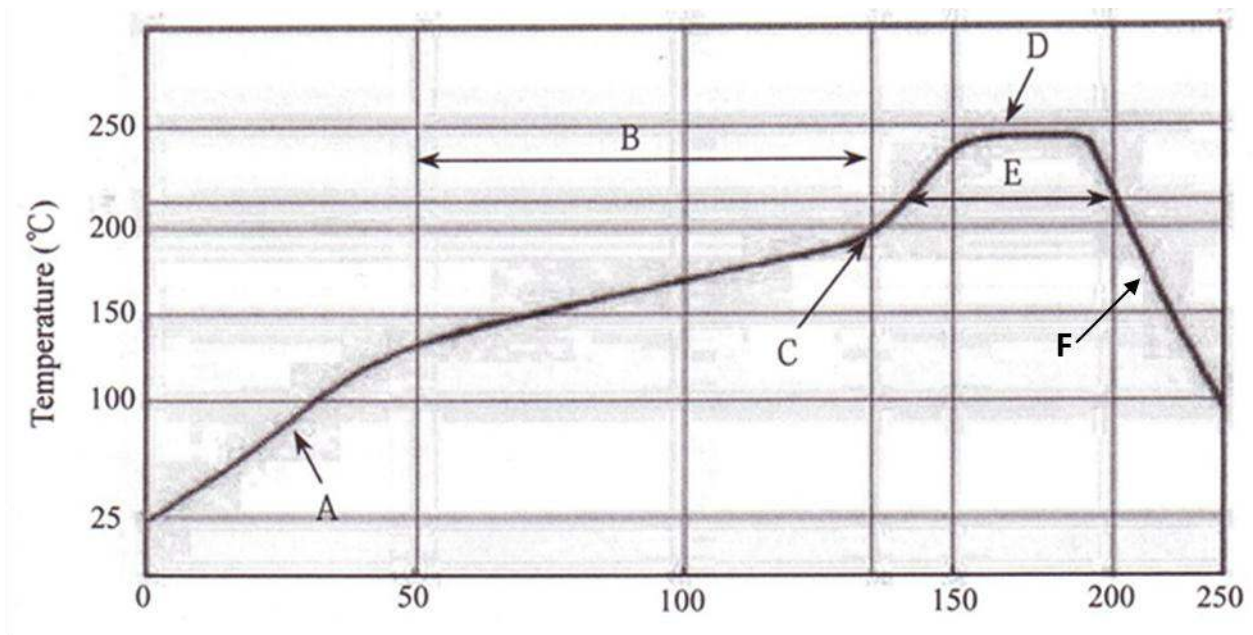

Figure 5-8: Reflow temperature profile.

PreHeat	
Temperature Ramp up rate for (A) ²	1.5~3.5 °C/s
Pre-heat time (B) ³ (130 – 200 ° C)	80 to 130 seconds
Pre-heat ending temperature (C) ⁴	180 to 200 ° C
Heating ⁵	
Peak Temperature range (D)	240 to 250 °C
Melting time that is the time over 220 °C (E)	50 to 75 seconds
Cool Down Ramp (F)	>2 °C/s

Table 5-1: Recommended reflow parameters.

Note:

1. Perform adequate test in advance as the reflow temperature profile will vary accordingly to the conditions of the parts and boards, and the specifications of the reflow furnace.
2. Max number of reflows supported are two
3. Be careful about rapid temperature rise in preheat zone as it may cause excessive slumping of the solder paste.
4. If the preheat is insufficient, rather large solder balls tend to be generated. Conversely, if performed excessively, fine balls and large balls will generate in clusters at a time.
5. If the temperature is too low, non-melting tends to be caused in the area with large heat capacity after reflow.
6. Be careful about sudden rise in temperature as it may worsen the slump of solder paste.
7. Be careful about slow cooling as it may cause the positional shift of parts and decline in joining strength at times.
8. A no clean flux should be used during SMT process.

Note:

The modules are shipped in sealed trays with the following conditions:

	<p>CAUTION This bag contains MOISTURE-SENSITIVE DEVICES</p>	<p>LEVEL</p> <div style="border: 1px solid black; padding: 5px; display: inline-block; width: 40px; text-align: center;"> <p>3</p> </div> <p><small>If Blank, see adjacent bar code label</small></p>
<p>1. Calculated shelf life in sealed bag: 12 months at < 40°C and < 90% relative humidity (RH)</p>		
<p>2. Peak package body temperature: 250 °C <small>If Blank, see adjacent bar code label</small></p>		
<p>3. After bag is opened, devices that will be subjected to reflow solder or other high temperature process must</p>		
<p>a) Mounted within: 168 hours of factory <small>If Blank, see adjacent bar code label</small></p>		
<p>conditions ≤ 30°C/60%</p>		
<p>b) stored at < 10% RH</p>		
<p>4. Devices require bake, before mounting, if:</p>		
<p>a) Humidity indicator card is > 10 % when read at 23 ± 5°C</p>		
<p>b) 3a or 3b not met</p>		
<p>5. If baking is required, devices may be baked for 48 hours at 125 ± 5°C</p>		
<p>Note: If device containers cannot be subjected to high temperature or shorter bake times are desired, reference IPC/JEDEC J-STD-033 for bake procedure</p>		
<p>Bag Seal Date: _____ <small>If Blank, see adjacent bar code label</small></p>		
<p>Note: Level and body temperature defined by IPC/JEDEC J-STD-020</p>		

6 Ordering Information

DEVICE DESCRIPTION	ORDERING NUMBER	Rev
Extended range module using PCB antenna	GS1011MEP	1.1
Extended range module using external antenna	GS1011MEE	1.1
Extended range module using PCB antenna	GS1011MEP	1.3 ¹
Extended range module using external antenna	GS1011MEE	1.3 ¹
DEVICE DESCRIPTION	ORDERING NUMBER	
Low power module using PCB antenna	GS1011MIP	1.2
Low power module using external antenna	GS1011MIE	1.2
Low power module using PCB antenna	GS1011MIP	1.3 ¹
Low power module using external antenna	GS1011MIE	1.3 ¹

1. Rev 1.3 uses B0 version of the GS1011 SoC

Note: Modules ship with only test code. Designers must first program the modules with a released firmware version. Designers should bring out GPIO27 pin (option to pull this pin to VDDIO during reset or power-on) and UART0 or SSPI pins to enable programming of firmware into the module. For details refer to the Programming GainSpan Modules document.

7 Regulatory Notes

Federal Communication Commission Interference Statement

This equipment has been tested and found to comply with the limits for a Class B digital device, pursuant to Part 15 of the FCC Rules. These limits are designed to provide reasonable protection against harmful interference in a residential installation. This equipment generates uses and can radiate radio frequency energy and, if not installed and used in accordance with the instructions may cause harmful interference to radio communications. However, there is no guarantee that interference will not occur in a particular installation. If this equipment does cause harmful interference to radio or television reception, which can be determined by turning the equipment off and on, the user is encouraged to try to correct the interference by one of the following measures:

- Reorient or relocate the receiving antenna.
- Increase the separation between the equipment and receiver.
- Connect the equipment into an outlet on a circuit different from that to which the receiver is connected.
- Consult the dealer or an experienced radio/TV technician for help.

FCC Caution: To assure continued compliance, (example - use only shielded interface cables when connecting to computer or peripheral devices). Any changes or modifications not expressly approved by the party responsible for compliance could void the user's authority to operate this equipment.

This device complies with Part 15 of the FCC Rules. Operation is subject to the following two conditions: (1) This device may not cause harmful interference, and (2) this device must accept any interference received, including interference that may cause undesired operation.

IMPORTANT NOTE:

FCC & IC Radiation Exposure Statement:

This equipment complies with FCC & IC radiation exposure limits set forth for an uncontrolled environment. This equipment should be installed and operated with minimum distance 20cm between the radiator & your body.

This transmitter must not be co-located or operating in conjunction with any other antenna or transmitter. This device is intended only for OEM integrators under the following conditions:

- 1) The antenna must be installed such that 20 cm is maintained between the antenna and users, and
- 2) The transmitter module may not be co-located with any other transmitter or antenna.

As long as 2 conditions above are met, further transmitter test will not be required. However, the

OEM integrator is still responsible for testing their end-product for any additional compliance requirements required with this module installed (for example, digital device emissions, PC peripheral requirements, etc.).

IMPORTANT NOTE: In the event that these conditions cannot be met (for example certain laptop configurations or co-location with another transmitter), then the FCC & IC authorizations are no longer considered valid and the FCC & IC IDs cannot be used on the final product. In these circumstances, the OEM integrator will be responsible for re-evaluating the end product (including the transmitter) and obtaining separate FCC & IC authorizations.

End Product Labeling

This transmitter module is authorized only for use in device where the antenna may be installed such that 20 cm may be maintained between the antenna and users (for example access points, routers, wireless ADSL modems, and similar equipment). The final end product must be labeled in a visible area with the corresponding FCC ID number.

IC Certification — Canada

The labeling requirements for Industry Canada are similar to those of the FCC. A visible label on the outside of the final product must display the IC labeling. The user is responsible for the end product to comply with IC ICES-003 (Unintentional radiators)

Manual Information That Must be Included

The user's manual for end users must include the following information in a prominent location.

IMPORTANT NOTE: To comply with FCC & IC RF exposure compliance requirements, the antenna used for this transmitter must be installed to provide a separation distance of at least 20 cm from all persons and must not be co-located or operating in conjunction with any other antenna or transmitter.

Other notes:

GainSpan modules have been built or under development for near body exposure applications. The 20cm statement is a standard note because absorption rate testing (commonly known as SAR or Specific absorption rate) is not modularly transferable for FCC/IC. Thus, if a radio is being used against the body, the end user is still responsible to test for regulatory near body exposure testing (for USA, please refer to the following):

- FCC Part 1.1037
- FCC Part 2.1091 Mobile Devices
- FCC Part 2.1093 Portable Devices
- FCC Part 15.247 (b) (4)

8 Limitations

THIS DEVICE AND ASSOCIATED SOFTWARE ARE NOT DESIGNED, MANUFACTURED OR INTENDED FOR USE OR RESALE FOR THE OPERATION OF APPLICATION IN A HAZARDOUS ENVIRONMENT, OR REQUIRING FAIL-SAFE PERFORMANCE, OR IN WHICH THE FAILURE OF PRODUCTS COULD LEAD DIRECTLY TO DEATH, PERSONAL INJURY, OR SEVERE PHYSICAL OR ENVIRONMENTAL DAMAGE (COLLECTIVELY, "HIGH RISK APPLICATIONS"). YOU AGREE AND ACKNOWLEDGE THAT YOU HAVE NO LICENSE TO, AND SHALL NOT (AND SHALL NOT ALLOW A THIRD PARTY TO) USE THE TECHNOLOGY IN ANY HIGH RISK APPLICATIONS, AND LICENSOR SPECIFICALLY DISCLAIMS ANY WARRANTY REGARDING, AND ANY LIABILITY ARISING OUT OF, HIGH RISK APPLICATIONS.

9 References

[1]	Title	Wireless LAN Medium Access Control (MAC) and Physical Layer (PHY) Specifications
	Reference	IEEE Standard 802.11-2007
	Version	
	Source	IEEE

[2]	Title	GS1011 Peripheral and Register Description
	Reference	GS1011-PRD
	Version	
	Source	GainSpan

[3]	Title	GS1011 ULTRA LOW-POWER WIRELESS SYSTEM-ON-CHIP DATA SHEET
	Reference	GS1011-DS
	Version	
	Source	GainSpan

[4]	Title	Programming the GainSpan Modules
	Reference	PG001
	Version	
	Source	GainSpan