



# DS\_USBC-FS-UART-5V-3.3V-1800-PH CABLE

## Datasheet

**Document Reference No.: CP\_000063**

**Version 1.1**

**Issue Date: 07-10-2020**

**Connective Peripherals Pte Ltd  
178 Paya Lebar Road, #07-03 Singapore 409030  
Tel.: +65 67430980 Fax: +65 68416071**

E-Mail (Support): [support@connectiveperipherals.com](mailto:support@connectiveperipherals.com) Web: [www.connectiveperipherals.com/products](http://www.connectiveperipherals.com/products)

Neither the whole nor any part of the information contained in, or the product described in this manual, may be adapted or reproduced in any material or electronic form without the prior written consent of the copyright holder. This product and its documentation are supplied on an as-is basis and no warranty as to their suitability for any particular purpose is either made or implied. Connective Peripherals Pte Ltd will not accept any claim for damages howsoever arising as a result of use or failure of this product. Your statutory rights are not affected. This product or any variant of it is not intended for use in any medical appliance, device or system in which the failure of the product might reasonably be expected to result in personal injury. This document provides preliminary information that may be subject to change without notice. No freedom to use patents or other intellectual property rights is implied by the publication of this document. Connective Peripherals Pte Ltd, 178 Paya Lebar Road, #07-03 Singapore 409030. Registered Number: 201617872E

**Copyright © Connective Peripherals Pte Ltd**

## 1 Introduction

The **USBC-FS-UART-5V-3.3V-1800-PH** is a USB Type C to TTL serial UART converter cable incorporating FT234XD USB to basic UART interface IC device which handles all the USB signalling and protocols. The cable provides a fast, simple way to connect devices with a TTL level serial interface to USB Type C.

USBC-FS-UART-5V-3.3V-1800-PH contains a small internal electronic circuit board, utilising the FT234XD, which is encapsulated into the USB Type C connector end of the cable. Refer to [DS\\_FT234XD](#), datasheet for details. The other end of the cable comes with 6-way SIL, 0.1" pitch connector – see Table 1.

The cable is FCC, CE, RoHS compliant and is available at TTL levels of +3.3V.

The USB Type C side of the cable is USB powered and USB 2.0 full speed compatible. The cable is 1.8m long and supports a data transfer rate up to 3 Mbaud.

The **USBC-FS-UART-5V-3.3V-1800-PH** requires USB drivers, available free from <https://www.ftdichip.com/FTDrivers.htm>, which are used to make the FT234XD in the cable appear as a virtual COM port (VCP). This then allows the user to communicate with the USB Type C interface via a standard PC serial emulation port (for example TTY). Another USB driver, the D2XX driver, can also be used with application software to directly access the FT234XD on the cable through a DLL. This is illustrated in the Figure 1-1.

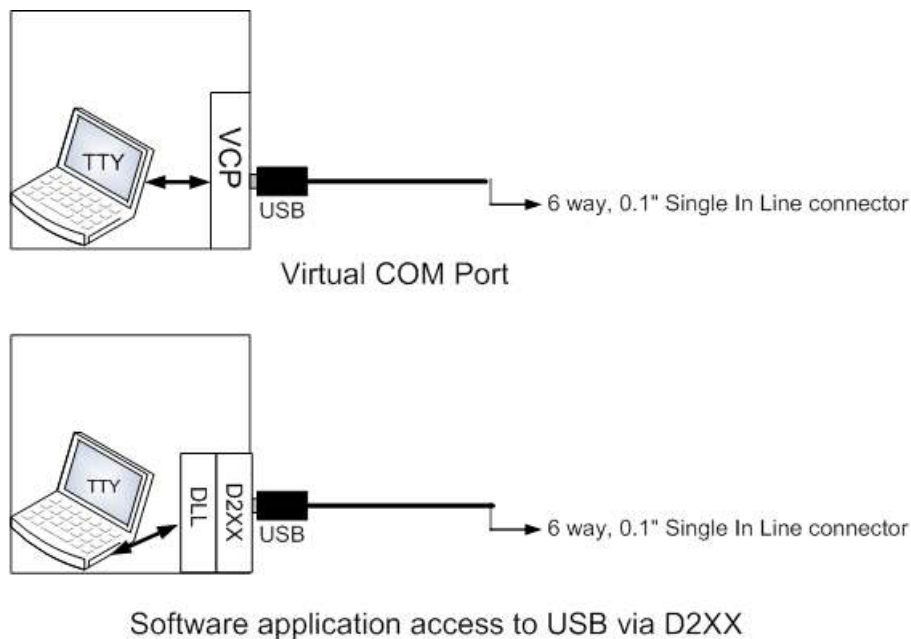

**Figure 1-1 Using the USBC-FS-UART-5V-3.3V-1800-PH**

## 1.1 Part Number

Table 1 gives details of the USBC-FS-UART-5V-3.3V-1800-PH part numbers.

Part Number	Description	End Connector*	Cable details
USBC-FS-UART-5V-3.3V-1800-PH	USB Type C to UART cable with +3.3V TTL level UART signals.	6 pin SIL, 0.1" pitch	6 core, UL2464 26 AWG, diam=4.8mm, Black

**Table 1 - USBC-FS-UART-5V-3.3V-1800-PH Description & Part Number**

CP supports customised end connector designs. For more information, please contact your local CP sales office (see section **5** for contact details).

## 1.2 Certifications

USBC-FS-UART-5V-3.3V-1800-PH is fully RoHS compliant as well as CE and FCC certified.



## 1.3 USB Compliant

The USBC-FS-UART-5V-3.3V-1800-PH is fully compatible with the USB 2.0 specification.

The FT234XD chipset used in this design has full USB-IF compliance.

## **Table of Contents**

<b>1</b>	<b>Introduction .....</b>	<b>1</b>
1.1	Part Number .....	2
1.2	Certifications .....	2
1.3	USB Compliant .....	2
<b>2</b>	<b>Typical Applications .....</b>	<b>4</b>
2.1	Driver Support .....	4
2.2	Features.....	5
<b>3</b>	<b>FT234XD Features relevant to USBC-FS-UART-5V-3.3V-1800-PH.....</b>	<b>6</b>
3.1	USBC-FS-UART-5V-3.3V-1800-PH Connector Pin Out and Mechanical details .....	6
3.2	USBC-FS-UART-5V-3.3V-1800-PH Signal Descriptions .....	7
	USBC-FS-UART-5V-3.3V-1800-PH Electrical Parameters .....	7
<b>4</b>	<b>Cable PCB Circuit Schematic.....</b>	<b>8</b>
<b>5</b>	<b>Contact Information.....</b>	<b>9</b>
	<b>Appendix A - Cable MTP MEMORY Configuration .....</b>	<b>10</b>
	<b>Appendix B - List of Figures and Tables .....</b>	<b>11</b>
	List of Figures .....	11
	List of Tables.....	11
	<b>Appendix C - Revision History .....</b>	<b>12</b>

## 2 Typical Applications

- USB to Serial TTL Level Converter
- Upgrading Legacy Peripherals to USB
- Interface Microcontroller UART or I/O to USB
- Interface FPGA / PLD to USB
- Firmware download and debug cable
- USB Instrumentation PC interface
- USB Industrial Control
- USB Software / Hardware Encryption Dongles
- "Maker" projects test cable

### 2.1 Driver Support

#### Royalty free VIRTUAL COM PORT

##### (VCP) DRIVERS for...

- Windows 10 32,64-bit
- Windows 8/8.1 32,64-bit
- Windows 7 32,64-bit
- Windows Server 2003, Server 2008 and server 2012 R2
- Windows CE 4.2, 5.0 and 6.0
- Mac OS OS-X
- Linux Kernel 3.0.0 and onwards

#### Royalty free D2XX Direct Drivers

##### (USB Drivers + DLL S/W Interface)

- Windows 10 32,64-bit
- Windows 8/8.1 32,64-bit
- Windows 7 32,64-bit
- Windows Server 2003, Server 2008 and server 2012 R2
- Windows CE 4.2, 5.0 and 6.0
- MAC OS-X
- Linux Kernel 3.0.0 and onwards
- Android (J2xx)

The drivers listed above are all available to download for free from <https://www.ftdichip.com/FTDrivers.htm>. Various Third Party Drivers are also available for various other operating systems - see [www.ftdichip.com](http://www.ftdichip.com) for details.

## 2.2 Features

- USBC-FS-UART-5V-3.3V-1800-PH Converter provides a USB Type C to TTL Serial interface with 6-way SIL, 0.1" pitch connector.
- On board FT234XD provides single chip USB to asynchronous serial data transfer interface.
- Entire USB protocol handled by the electronics in the cable USB Type C.
- Connect directly to a microcontroller UART or I/O pins.
- UART interface support for 7 or 8 data bits, 1 or 2 stop bits and odd / even / mark / space / no parity.
- Fully assisted hardware (RTS#/CTS#) or X-On / X-Off software handshaking.
- Data transfer rates from 300 baud to 3 Mbaud at TTL levels.
- Internal MTP MEMORY with user writeable area.
- FTDI's royalty-free VCP allows for communication as a standard emulated COM port and D2XX 'direct' drivers provide DLL application programming interface.
- +5V output allows external logic to be powered from the USB Type C port.
- 6 way outputs provide Tx, Rx, RTS#, CTS#, VCC and GND.
- Low USB bandwidth consumption.
- UHCI / OHCI / EHCI host controller compatible.
- USB 2.0 Full Speed compatible.
- -40°C to +85°C operating temperature range.
- Cable length is 1.80m (6 feet).
- FCC and CE compliant.
- Custom versions also available (subject to MOQ).

### 3 FT234XD Features relevant to USBC-FS-UART-5V-3.3V-1800-PH

The USBC-FS-UART-5V-3.3V-1800-PH uses FTDI's FT234XD USB to serial IC device. This section summarises the key features of the FT234XD which apply to the USBC-FS-UART-5V-3.3V-1800-PH USB to serial TTL converter cables. For further details, and a full features and enhancements description, refer to [FT234XD](#) datasheet.

**Internal MTP MEMORY.** The internal MTP MEMORY in the cable is used to store USB Vendor ID (VID), Product ID (PID), device serial number, product description string and various other USB configuration descriptors. Each cable is supplied with the internal MTP MEMORY pre-programmed as described in Appendix A - Cable MTP MEMORY Configuration. A user area of the internal MTP MEMORY is available to system designers to allow storing additional data. The internal MTP MEMORY descriptors can be programmed in circuit, over USB without any additional voltage requirement. It can be programmed using the FTDI utility software called [FT\\_PROG](#), which can be downloaded from [FTDI Utilities](#).

**Lower Operating and Suspend Current.** The FT234XD has a low 8mA operating supply current and a very low USB suspend current of approximately 125µA. (Note that during suspend mode, the current drawn by an application should not exceed 2.5mA to remain USB compliant)

**UART Pin Signal Inversion.** The sense of each of the four UART signals can be individually inverted by configuring options in the internal MTP MEMORY. For example CTS# (active low) can be changed to CTS (active high), or TXD can be changed to TXD#.

**Improved EMI Performance.** The USBC-FS-UART-5V-3.3V-1800-PH is FCC and CE certified.

**Extended Operating Temperature Range** - The USBC-FS-UART-5V-3.3V-1800-PH are capable of operating over an extended temperature range of -40° C to +85° C thus allowing them to be used in automotive or industrial applications.

The USBC-FS-UART-5V-3.3V-1800-PH are terminated by a 6 way, 0.1", Single-In-Line (SIL) connector. The USBC-FS-UART-5V-3.3V-1800-PH operates at +3.3V levels (signals only, VCC= +5V).

#### 3.1 USBC-FS-UART-5V-3.3V-1800-PH Connector Pin Out and Mechanical details

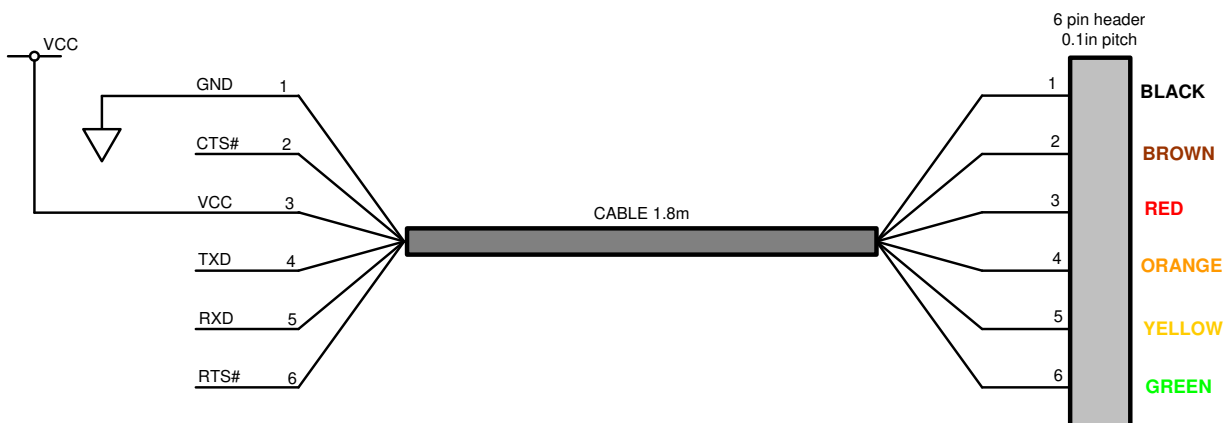
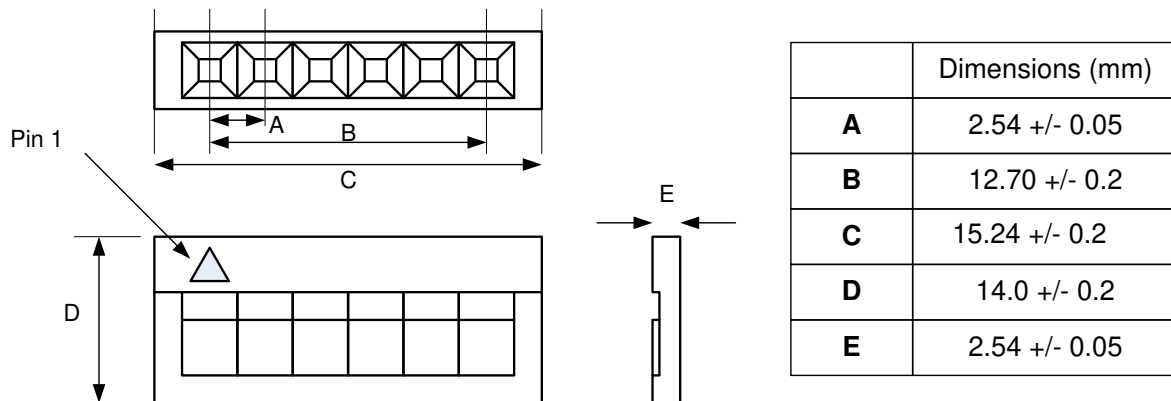

Figure 3-1 USBC-FS-UART-5V-3.3V-1800-PH, 6 Way Header Pin Out

The mechanical details of the 6 way connector are shown in the following diagram -



**Figure 3-2 USBC-FS-UART-5V-3.3V-1800-PH, 6 Way Header Mechanical Details**

### 3.2 USBC-FS-UART-5V-3.3V-1800-PH Signal Descriptions

Header Pin Number	Name	Type	Colour	Description
1	GND	GND	Black	Device ground supply pin.
2	CTS#	Input	Brown	Clear to Send Control input / Handshake signal.
3	VCC	Output	Red	+5V output,
4	TXD	Output	Orange	Transmit Asynchronous Data output.
5	RXD	Input	Yellow	Receive Asynchronous Data input.
6	RTS#	Output	Green	Request To Send Control Output / Handshake signal.

**Table 2 - USBC-FS-UART-5V-3.3V-1800-PH Signal Descriptions**

### USBC-FS-UART-5V-3.3V-1800-PH Electrical Parameters

Parameter	Description	Minimum	Typical	Maximum	Units	Conditions
V <sub>CC</sub>	Supply Voltage	4.75	5.0	5.25	V	Dependant on the USB Type C port that the USBC-FS-UART-5V-3.3V-1800-PH is connected to
I <sub>CC</sub>	Supply Current	-	-	450	mA	Assuming connected to direct to a host port or a powered hub, and enumerated
T	Operating Temperature Range	-40	-	+85	°C	

**Table 3 - USBC-FS-UART-5V-3.3V-1800-PH Electrical Parameters**

Parameter	Description	Minimum	Typical	Maximum	Units	Conditions
V <sub>oh</sub>	Output Voltage High	2.97	V <sub>CCIO</sub>	V <sub>CCIO</sub>	V	V <sub>CCIO</sub> =3.3V
V <sub>ol</sub>	Output Voltage Low	-	0	0.4	V	
V <sub>il</sub>	Input Low Switching Threshold	-	-	0.8	V	LVTTTL
V <sub>ih</sub>	Input High Switching Threshold	2	-	-	V	LVTTTL

**Table 4 - USBC-FS-UART-5V-3.3V-1800-PH I/O Pin Characteristics**



## 4 Cable PCB Circuit Schematic

The circuit schematic for the small internal electronic circuit board, utilising the FT234XD, which is encapsulated into the USB Type C connector end of the cable, is shown in Figure 4-1.

Customised versions of these cables are also available. Users interested in customised versions of these cables should CP Sales - [sales@connectiveperipherals.com](mailto:sales@connectiveperipherals.com).

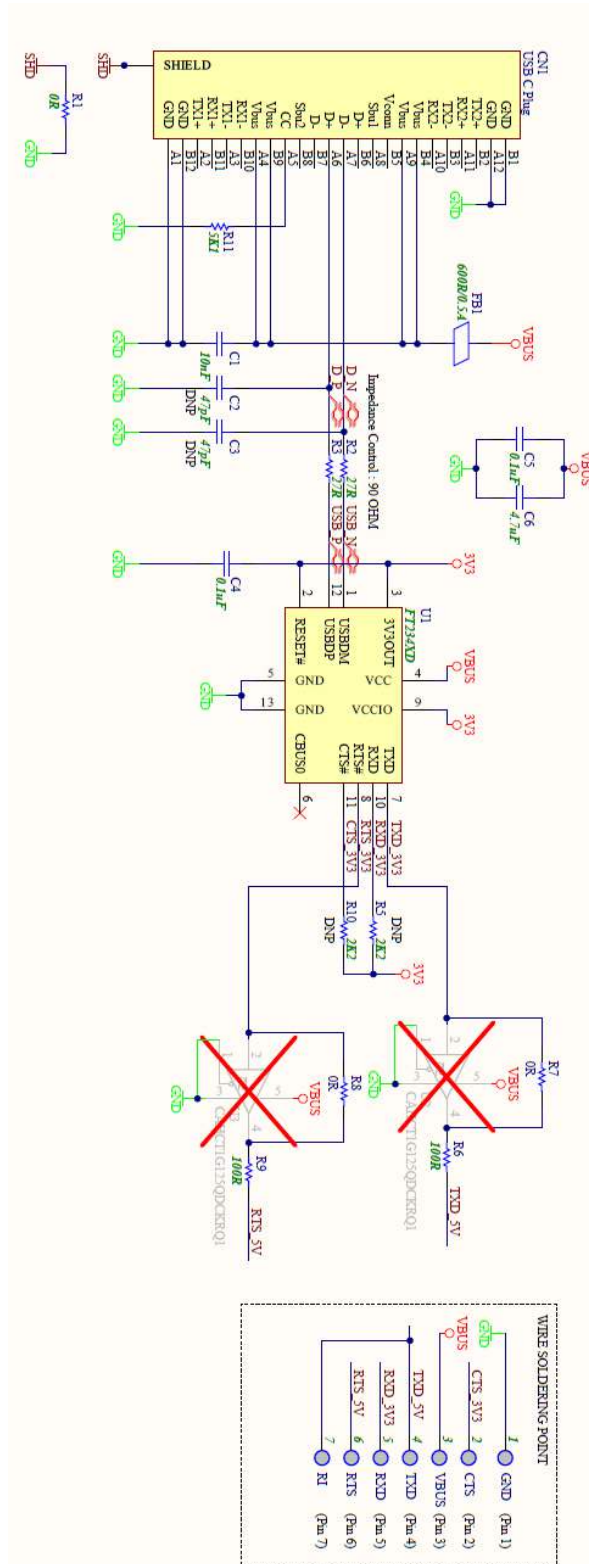

**Figure 4-1 Circuit Schematic of PCB Used in the TTL to USB-C Serial Converter Cables**

## 5 Contact Information

### Global Headquarters – Singapore

Connective Peripherals Pte Ltd  
178 Paya Lebar Road  
#07-03  
Singapore 409030

Tel: +65 67430980  
Fax: +65 68416071

E-Mail (Sales)	<a href="mailto:sales@connectiveperipherals.com">sales@connectiveperipherals.com</a>
E-Mail (Support)	<a href="mailto:support@connectiveperipherals.com">support@connectiveperipherals.com</a>
Web Site URL	<a href="http://www.connectiveperipherals.com">http://www.connectiveperipherals.com</a>
Web Shop URL	<a href="http://www.connectiveperipherals.com">http://www.connectiveperipherals.com</a>

## Appendix A - Cable MTP MEMORY Configuration

Each USBC-FS-UART-5V-3.3V-1800-PH cable is controlled by the FTDI FT234XD IC. This FT234XD device contains an MTP MEMORY which contains the USB configuration descriptors for that device. When the cable is plugged into a PC or a USB reset is performed, the PC will read these descriptors. The default values stored into the internal MTP MEMORY are defined in Table 5.

Parameter	Value	Notes
USB Vendor ID (VID)	0403h	FTDI default VID (hex)
USB Product UD (PID)	6015h	FTDI default PID (hex)
Serial Number Enabled?	Yes	
Serial Number	See Note	A unique serial number is generated and programmed into the MTP MEMORY during device final test.
Pull down I/O Pins in USB Suspend	Disabled	Enabling this option will make the device pull down on the UART interface lines when the power is shut off (PWREN# is high).
Manufacturer Name	FTDI	
Product Description	See note	Product description depends on the cable. The following lists the Product description for each different cable. USBC-FS-UART-5V-3.3V-1800-PH
Max Bus Power Current	90mA	
Power Source	Bus Powered	
Device Type	FT234XD	
USB Version	0200	Returns USB 2.0 device description to the host. <b>Note:</b> The device is a USB 2.0 Full Speed device (12Mb/s) as opposed to a USB 2.0 High Speed device (480Mb/s).
Remote Wake Up	Disabled	
Load VCP Driver	Enabled	Makes the device load the VCP driver interface for the device
Invert TXD	Disabled	Signal on this pin becomes TXD# if enable.
Invert RXD	Disabled	Signal on this pin becomes RXD# if enable.
Invert RTS#	Disabled	Signal on this pin becomes RTS if enable.
Invert CTS#	Disabled	Signal on this pin becomes CTS if enable.

**Table 5 - Default Internal MTP MEMORY Configuration**

The internal MTP MEMORY in the cable can be re-programmed over USB using the utility program [FT\\_PROG](#). Version 2.8a or later is required for the FT234XD chip. Users who do not have their own USB Vendor ID but who would like to use a unique Product ID in their design can contact CP Sales - [Sales@connectiveperipherals.com](mailto:Sales@connectiveperipherals.com) for a free block of unique PIDs. Contact CP support - [support@connectiveperipherals.com](mailto:support@connectiveperipherals.com) for any support service.

---

## **Appendix B - List of Figures and Tables**

### **List of Figures**

Figure 1-1 Using the USBC-FS-UART-5V-3.3V-1800-PH .....	1
Figure 3-1 USBC-FS-UART-5V-3.3V-1800-PH, 6 Way Header Pin Out .....	6
Figure 3-2 USBC-FS-UART-5V-3.3V-1800-PH, 6 Way Header Mechanical Details.....	7
Figure 4-1 Circuit Schematic of PCB Used in the TTL to USBC Serial Converter Cables .....	8

### **List of Tables**

Table 1 - USBC-FS-UART-5V-3.3V-1800-PH Description & Part Number .....	2
Table 2 - USBC-FS-UART-5V-3.3V-1800-PH Signal Descriptions.....	7
Table 3 - USBC-FS-UART-5V-3.3V-1800-PH Electrical Parameters.....	7
Table 4 - USBC-FS-UART-5V-3.3V-1800-PH I/O Pin Characteristics .....	7
Table 5 - Default Internal MTP MEMORY Configuration.....	10

---

## Appendix C - Revision History

Revision	Changes	Date
Version 1.0	Initial Release	29-07-2020
Version 1.1	Updated the Part Number & Device Description	07-10-2020