

REVISIONS				
P	LTR	DESCRIPTION	DATE	APVD
	E4	REVISED PER ECN-21-127537	23NOV2021	RK CDS

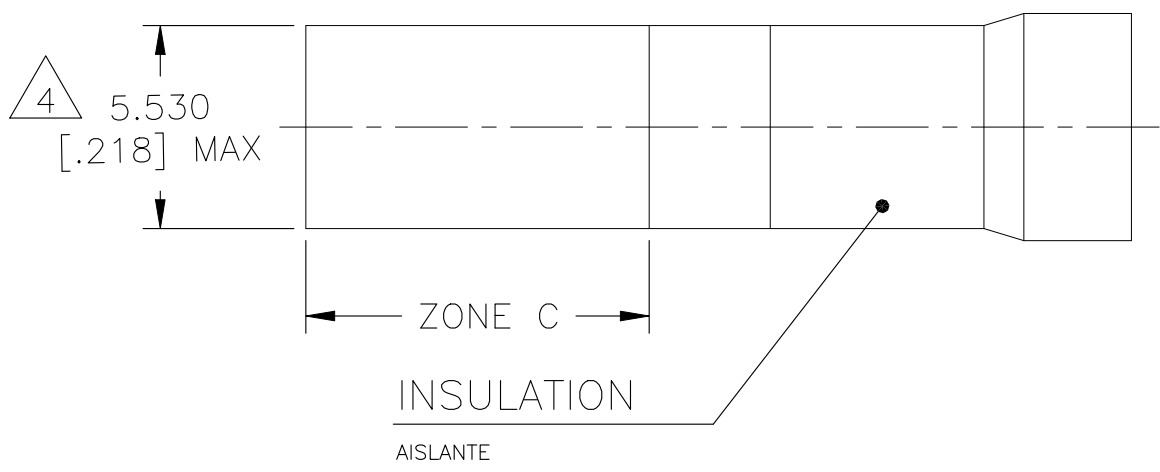
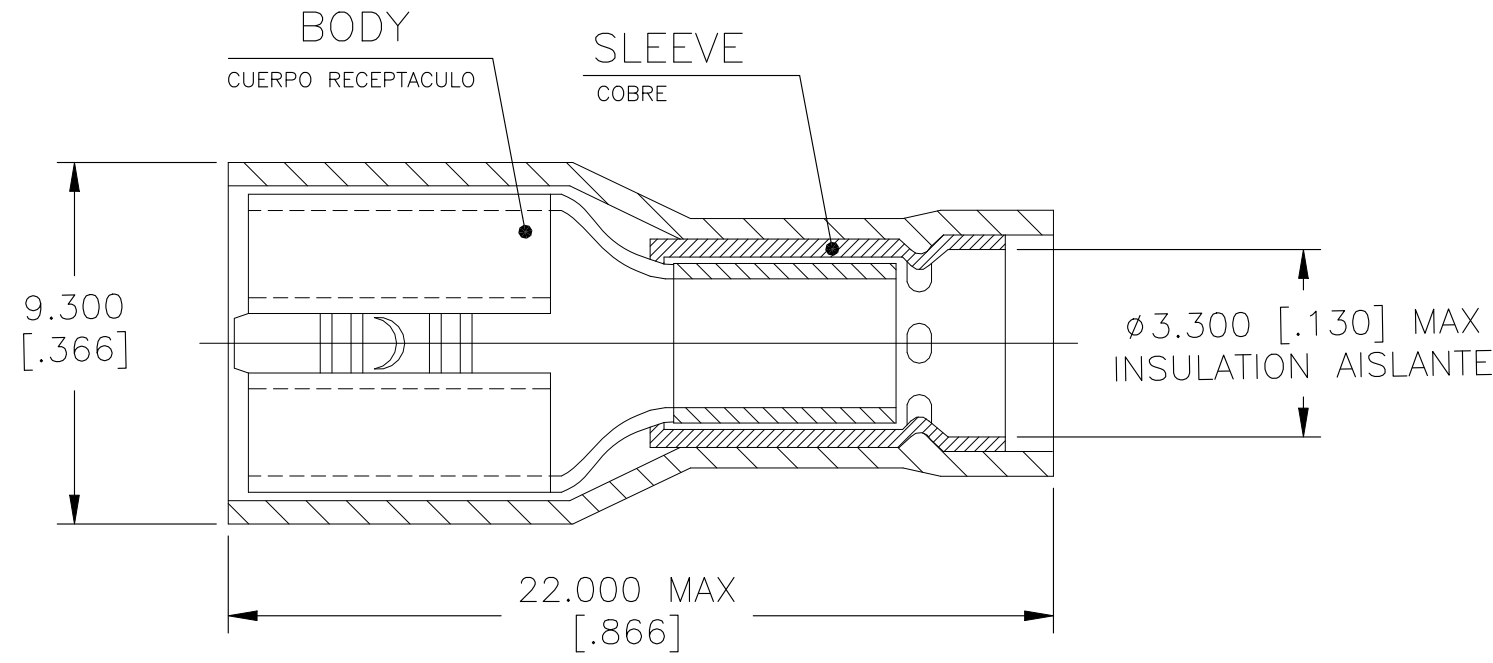

- 1. MATERIAL:  
 BODY: SEE TABLE  
 SLEEVE: COPPER PER ASTM B152  
 INSULATION: POLYAMIDE 6/6 (NYLON) PER ASTM D4066  
  
 MATERIAL:  
 CUERPO: VER TABLA  
 MANGA: COBRE POR ASTM B152  
 AISLAMIENTO: POLIAMIDA 6/6 (NYLON) POR ASTM D4066
- 2. FINISH:  
 BODY: TIN PLATE 0.002 [.000079]  
 MIN EXT THICK PER ASTM B545  
 SLEEVE: NONE  
 INSULATION, COLOR: RED
- TERMINAR:  
 CUERPO: HOJA DE HOJALATA 0.002 [.000079]  
 ESPESOR MÍNIMO EXT. POR ASTM B545  
 MANGA: NINGUNA  
 COLOR DE, AISLAMIENTO: ROJO
- 3. WIRE RANGE: 0.300 [.012] – 1.000 [.039] mm<sup>2</sup> [22–18 AWG]  
 GAMA DE ALAMBRE: 0.300 [.012] – 1.000 [.039] mm<sup>2</sup> [22–18 AWG]
- 4. DIMENSION APPLIES TO ZONE C FOR A DISTANCE OF 8.730 – 8.860 [.344 – .349]

LOOSE PIECE PIEZA SUELTA	100	BRASS PER ASTM B36 LATÓN POR ASTM B36	735279
PACKAGE TYPE TIPO DE PAQUETE	QTY CANTIDAD	BODY MATL. CUERPO MATL.	PART NUMBER NÚMERO DE PIEZA

THIS DRAWING IS A CONTROLLED DOCUMENT.		DWN RAVI S 15NOV2019	<b>STE</b> TE Connectivity													
DIMENSIONS: mm [INCHES]		CHK DANIEL ROHDE 15NOV2019														
TOLERANCES UNLESS OTHERWISE SPECIFIED:		APVD DANIEL ROHDE 15NOV2019	NAME FULLY INSULATED FASTON RCPT 6.35 MM (RED) RECEPTÁCULO FASTON 6.35 MM AISLADO (ROJO)													
<table border="0"> <tr><td>0 PLC</td><td>± -</td></tr> <tr><td>1 PLC</td><td>± -</td></tr> <tr><td>2 PLC</td><td>± -</td></tr> <tr><td>3 PLC</td><td>± 0.500 [.019]</td></tr> <tr><td>4 PLC</td><td>± -</td></tr> <tr><td>ANGLES</td><td>± -</td></tr> </table>		0 PLC	± -	1 PLC	± -	2 PLC	± -	3 PLC	± 0.500 [.019]	4 PLC	± -	ANGLES	± -	PRODUCT SPEC -	RESTRICTED TO -	
0 PLC	± -															
1 PLC	± -															
2 PLC	± -															
3 PLC	± 0.500 [.019]															
4 PLC	± -															
ANGLES	± -															
MATERIAL SEE TABLE VER TABLA		FINISH △	APPLICATION SPEC -	SIZE A3												
		WEIGHT -	CAGE CODE 00779	DRAWING NO C-735279												
CUSTOMER DRAWING			SCALE 5:1	SHEET 1 OF 1												
			REV E4													