

SECTION X-X  
INSULATION BARREL  
SCALE 20:1

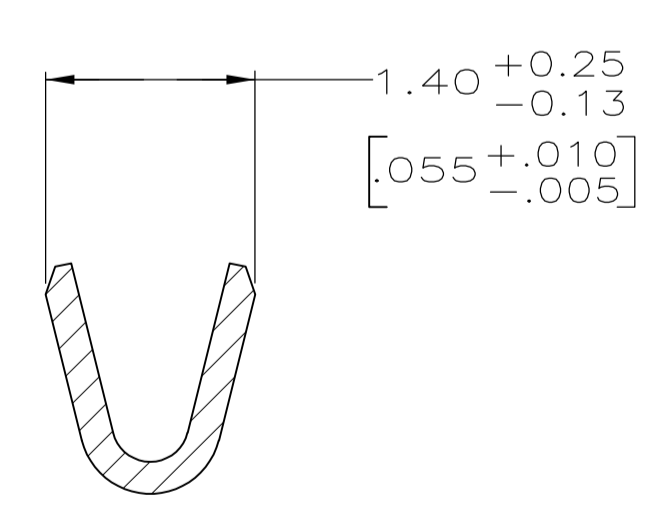

SECTION Y-Y  
WIRE BARREL  
SCALE 20:1

- 1 FOR MINI-APPLICATOR AND STRIPPER CRIMPER.
- 2 FOR HAND TOOL USE ONLY.
- 3 FOR STANDARD APPLICATOR PART #566184 ONLY.
- 4. WIRE RANGE OF 24-28, INSULATION RANGE OF .030-.040.
- 5. GOLD PLATING MAY NOT APPEAR ON CARRIER STRIP. NICKEL UNDERPLATE COVERS ENTIRE CONTACT.
- 6 GOLD PLATING PER MIL-G-45204. NICKEL PLATING PER QQ-N-290, TIN PLATING PER MIL-T-10727. COPPER PLATING PER MIL-C-14550.
- 7 PLATED, 1.27µm [.000050] MIN GOLD ON LOCALIZED GOLD PLATE AREA AND ZONE 1 OVER 1.27µm [.000050] MIN NICKEL.
- 8 GOLD PLATED IN LOCALIZED GOLD PLATE AREA AS FOLLOWS:  
0.76µm [.000030] MIN GOLD IN MATED AREA, GOLD FLASH ON REMAINDER OF LOCALIZED GOLD PLATE AREA AND ZONE 1 OF CONTACT, ALL OVER 1.27µm [.000050] MIN NICKEL UNDERPLATE.  
OR  
GOLD FLASH OVER PALLADIUM-NICKEL PLATE, 0.76µm [.000030] MIN TOTAL IN MATED AREA, GOLD FLASH ON REMAINDER OF LOCALIZED GOLD PLATE AREA AND ZONE 1 OF CONTACT, ALL OVER 1.27µm [.000050] MIN NICKEL UNDERPLATE.
- 9 PLATED WITH GOLD FLASH ON LOCALIZED GOLD PLATE AREA AND ZONE 1 OVER 0.76µm [.000030] MIN NICKEL.
- 10 PLATED WITH 2.54µm-5.08µm [.000100-.000200] TIN.
- 11 PLATED WITH 1.27µm [.000050] MIN GOLD IN LOCALIZED GOLD PLATE AREA, GOLD FLASH ON ZONE 1, OVER 1.27µm [.000050] MIN NICKEL.
- 12 GOLD PLATED IN LOCALIZED GOLD PLATED AREA, 0.76µm [.000030] GOLD IN MATED AREA, TIN PLATED WIRE BARRELS, OVER 1.27µm [.000050] NICKEL.
- 13 PLATED WITH GOLD FLASH IN LOCALIZED GOLD PLATE AREA, TIN PLATED WIRE BARRELS, OVER 0.76µm [.000030] NICKEL.
- 14 GOLD PLATED IN LOCALIZED GOLD PLATED AREA, 0.38µm [.000015] GOLD IN MATED AREA, GOLD FLASH ON REMAINDER, OVER 1.27µm [.000050] NICKEL.
- 15 AMP ITALY PART NUMBER ONLY.
- 16 GOLD PLATED IN LOCALIZED GOLD PLATED AREA, 0.03µm [.000001] GOLD IN MATED AREA, 0.76µm [.000030] MIN TIN OR TIN-LEAD ON WIRE BARRELS, ALL OVER 0.76µm [.000030] MIN NICKEL.
- 17 COMPANY LOGO ON BOTTOM OF EITHER WIRE OR INSULATION BARRELS.

OBSOLETE	STANDARD	12	3	STRIP	6-66507-3
OBSOLETE	STANDARD	16	1	STRIP	6-66507-2
OBSOLETE	STANDARD	13	2	LOOSE PIECE	5-66507-9
OBSOLETE	STANDARD	12	2	LOOSE PIECE	5-66507-7
OBSOLETE	STANDARD	13	1	STRIP	3-66507-1
OBSOLETE	STANDARD	12	1	STRIP	3-66507-0
	STANDARD	11	1	STRIP	2-66507-8
	STANDARD	11	3	STRIP	2-66507-7
OBSOLETE	STANDARD	10	1	STRIP	1-66507-4
	STANDARD	9	2	LOOSE PIECE	1-66507-0
	STANDARD	8	2	LOOSE PIECE	66507-9
	STANDARD	7	2	LOOSE PIECE	66507-8
	STANDARD	9	1	STRIP	66507-4
	STANDARD	8	1	STRIP	66507-3
	STANDARD	7	1	STRIP	66507-2
	PACKAGING TYPE	FINISH	USE	TYPE	PART NUMBER

SUPERSEDED BY 66507-9

THIS DRAWING IS A CONTROLLED DOCUMENT. DIMENSIONING AND TOLERANCING PER ASME Y14.5M-2009.

APPROVED: S. WELDON (9-9-86), C. RICHARD (9-9-86), V. KUMAR (9-10-86)

NAME: PIN CONTACT, SIZE 20 DF, 24-28 AWG, AMPLIMITE

APPLICATION SPEC: 114-10000

MATERIAL: BRASS

FINISH: 6

WEIGHT: -

CUSTOMER DRAWING

SCALE: 10:1

SHEET: 1 OF 1

REV: AU

STE TE Connectivity