

M5X0.8-6H 8mm(2X) DEEP THREADED INSERT

RECOMMENDED TORQUE VALUES: 1.9-2.2 N.m

REVISIONS					
REV	ECO	DESCRIPTION	DATE	BY	APPR
A1	--	RELEASE NEW DRAWING	15JUL20	VITO	TOMMY
A2	--	REVISE THE VIEWS	1/MAR/23	VITO	TOMMY

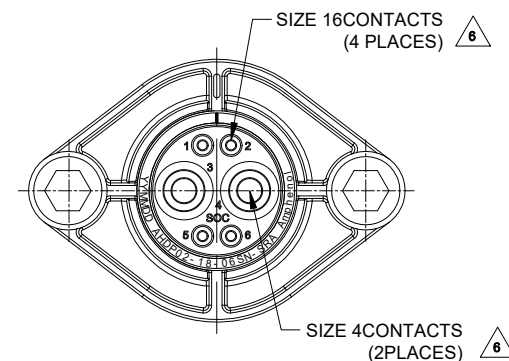

NOTES: UNLESS OTHERWISE SPECIFIED

1. MATERIAL:

HOUSING: THERMOPLASTIC; BLACK  
 SEAL: SILICONE RUBBER  
 THREADED INSERT: STAINLESS STEEL

2. MODIFICATIONS: SMOOTH RING ADAPTER(SRA);

STANDARD DIA. WIRE SEAL;  
 SEALED PANEL MOUNT;

3. SPECIFICATIONS:

- 3.1 OPERATING TEMPERATURE: -55°C TO +125°C.
- 3.2 DIELECTRIC WITHSTANDING VOLTAGE: LESS THAN 2 MILLIAMPS CURRENT LEAKAGE @ 1500 VOLTS AC.
- 3.3 INSULATION RESISTANCE: 1000 MEGOHM MIN @ 25°C.
- 3.4 MOISTURE RESISTANCE: IP67&IP69K ( MATED CONDITION ).
- 3.5 MATING CYCLE DURABILITY: 100 CYCLES
- 3.6 RoHS COMPLIANT

4. MATING PART: AHDP06-18-06P\* (\* = SEAL TYPE)

5. ALL DIMENSIONS ARE FOR REFERENCE USE ONLY.

6 CONTACT SIZE AND WIRE RANGE:

CONTACT SIZE	MIN. INSUL O.D.	MAX. INSUL O.D.	TYPICAL WIRE RANGE	CURRENT RATING
16	2.54 mm (.100in)	3.40 mm (.134 in)	14-20 AWG (2.0-0.5mm <sup>2</sup> )	13 AMPS
4	6.63 mm (.261in)	7.41mm (.292 in)	6 AWG (16-13mm <sup>2</sup> )	100 AMPS

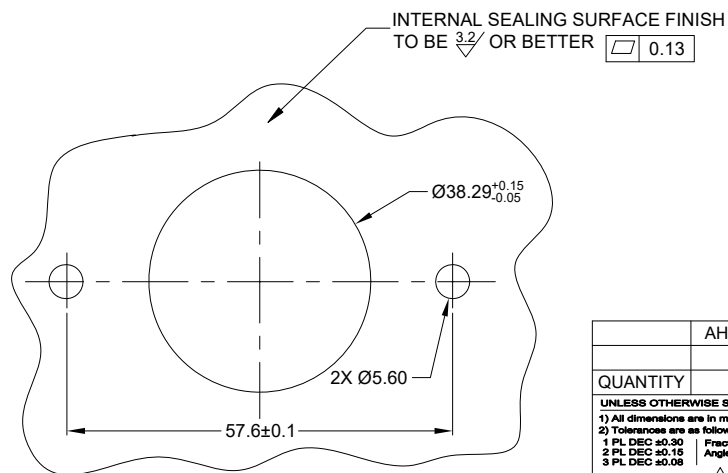

RECOMMENDED PANEL MOUNTING HOLE

RECOMMENDED PANEL THICKNESS: 1.6 TO 4.7MM

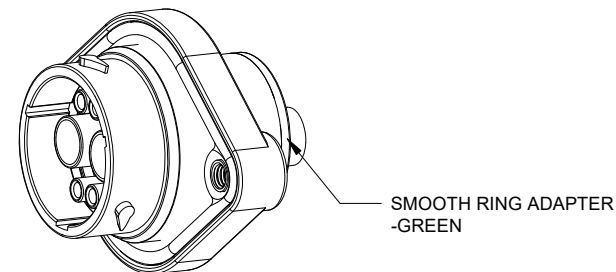

AHDP02-18-06SN-SRA		DESCRIPTION		ITEM
PART NUMBER		DESCRIPTION		ITEM
QUANTITY		MATERIALS LIST		
UNLESS OTHERWISE SPECIFIED		SIGNATURES DATE		
1) All dimensions are in metric(mm).		DRAWN: VITOLI 1/MAR/23		
2) Tolerances are as follows:		CHECKED: ORONLI 2/MAR/23		
1 PL DEC ±0.30 Fractions ±1/64		ENGINEER:		
2 PL DEC ±0.15 Angles ±1°		APPROVAL: TOMMY XIE 3/MAR/23		
3 PL DEC ±0.08		CUSTOMER:		
3) Note reference =		THIS DRAWING IS SUPPLIED FOR INFORMATION ONLY. DESIGN FEATURES, SPECIFICATIONS AND PERFORMANCE DATA SHOWN HEREON ARE THE PROPERTY OF THE AMPHENOL CORPORATION. NO RIGHTS OF REPRODUCTION ARE IMPLIED. ALL DIMENSIONS ARE SUBJECT TO NORMAL MANUFACTURING VARIATIONS.		
MATERIAL SPECIFICATIONS:		SIZE TYPE DWG NO. REVISION		
PROCESS SPECIFICATIONS:		B C- AHDP02-18-06SN-SRA A2		
NEXT ASSY:		SCALE: NONE SHEET 1 OF 1		

TITLE: 6POS RECEPTACLE SOCKET PANELMATE AHDP SIZE 18, NORMAL SEAL, SRA

DWG NO:

AHDP02-18-06SN-SRA

REV: A2

SH: 1

OF: 1