

PART NO.

RFD-1644-2SR2

| REV | DESCRIPTION | DWN | DATE | APPROVED |
|-----|--------------------------|-----|----------|----------|
| E | UPDATED DESIGN AND SPECS | CZS | 11/12/19 | JDMc |

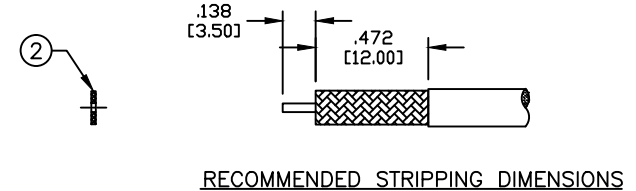
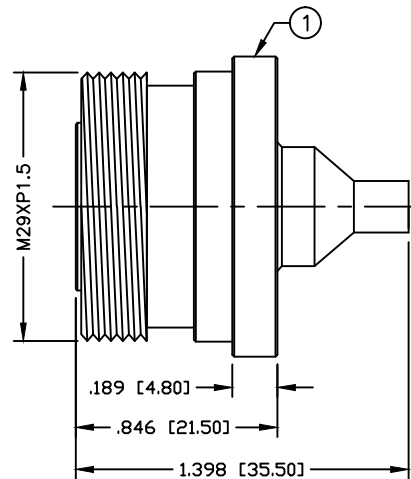
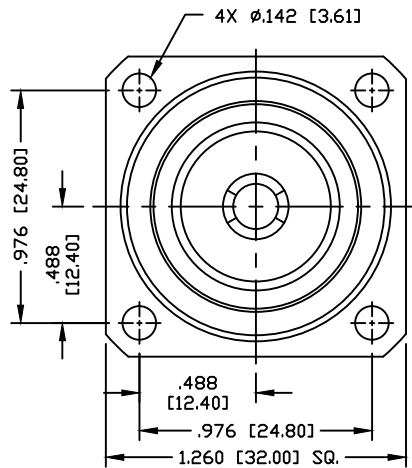

1. STRIP CABLE TO DIMENSION SHOWN.
2. SLIDE INSULATOR ONTO CABLE CENTER CONDUCTOR.
3. INSERT CABLE INTO THE CABLE ENTRY UNTIL THE CABLE YIELDS IN PLACE INSIDE REAR CONTACT.
4. SOLDER OUTER CABLE CONDUCTOR AT CABLE ENTRY.
5. INSPECT SOLDER JOINT FOR VOIDS.

SPECIFICATIONS:

INTERFACE: IEC61169-4

IMPEDANCE: 50 Ohms

FREQUENCY RANGE: 0-3 GHz

VSWR: $\leq 1.1@1\text{GHz}$ / $\leq 1.15@3\text{GHz}$ 3rd ORDER IM: $\leq -160\text{dBc}$ (RELATIVE TO CARRIER)

3rd ORDER IM TEST METHOD: 2x43dBm CARRIERS

DIELECTRIC WITHSTANDING VOLTAGE: 1000V/AC

INSULATION RESISTANCE: 10000M Ω

TEMPERATURE RANGE: -40°C TO 155°C

MECHANICAL DURABILITY: 500 CYCLES

FOR .141 SEMI RIGID, RG-402/U & BELDEN 1673A CABLE

| | |
|--|--|
| CUSTOMER OUTLINE DRAWING | |
| ALL DIMENSIONS ARE REFERENCE ONLY | |
| UNLESS OTHERWISE SPECIFIED: DIMENSIONS ARE IN INCHES AND [MILLIMETERS] | |

| | |
|------------------------|----------|
| DRAWN C. ZUNIGA | 11/12/19 |
| CHECKED | |
| ORJ DRAWN C. ZUNIGA | 02/15/99 |

**RoHS
COMPLIANT**

PROPRIETARY AND CONFIDENTIAL
THIS DRAWING CONTAINS
INFORMATION PROPRIETARY TO
RF INDUSTRIES, ANY
UNAUTHORIZED USE OF THIS
DRAWING IS EXPRESSLY
PROHIBITED WITHOUT WRITTEN
PERMISSION FROM RF
INDUSTRIES. ANY VIOLATION IS
PUNISHABLE UNDER U.S.
COPYRIGHT LAWS.

RFconnectors
DIVISION OF RF INDUSTRIES, LTD.

7610 MIRAMAR RD.
SAN DIEGO, CA 92126
(858) 549-6340
(858) 549-6345 FAX

7/16 DIN JACK
DIRECT SOLDER, 4 HOLE FLANGE

| | | | |
|---------------|-------------------------|---------------------------------|---------------|
| SIZE A | CABLE GROUP SR2 | DWG NO. RFD-1644-2SR2 | REVISION E |
| SCALE: NTS | ENGINEERING ID: 1787 | SHEET 1 OF 1 | |

| # | DESCRIPTION | QTY | MATERIAL | FINISH |
|---|-------------|-----|-----------------|--------------|
| 4 | INSULATOR | 1 | PTFE | --- |
| 3 | CONTACT | 1 | PHOSPHOR BRONZE | SILVER |
| 2 | INSULATOR | 1 | PTFE | --- |
| 1 | BODY | 1 | BRASS | WHITE BRONZE |